

U.S. EPA

United States Environmental
Protection Agency
Office of Noise Abatement
and Control ANR-480
Washington, DC 20460

CEC

Commission of the
European Communities
Environment and Consumer
Protection Service
200, rue de la Loi
B1049 Brussels
Belgium

N-96-01
II-A-115
December 1980

EPA 550/9-80-222

**A Comparison of Sound
Power Levels from Portable
Air Compressors Based
Upon Test Methodologies
Adopted By U.S. EPA
and the CEC**

OFFICE COPY

**PROPERTY
OF
EPA/ONAC**

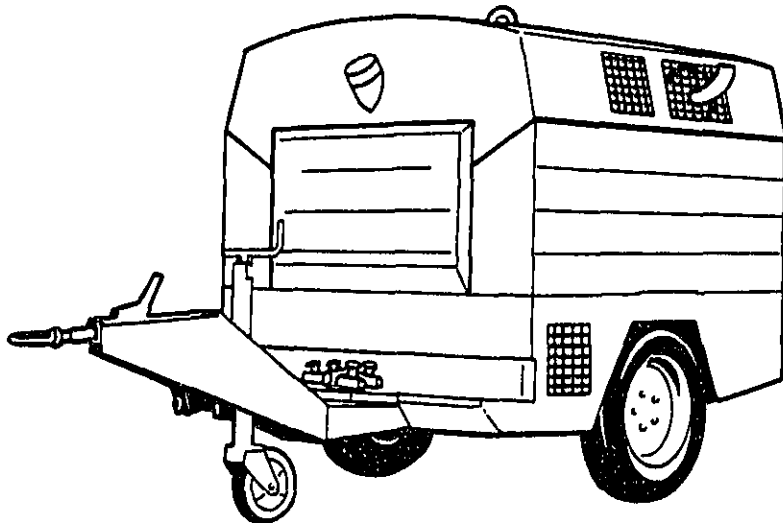

N-96-01
II-A-115

A COMPARISON OF SOUND POWER
LEVELS FROM PORTABLE AIR COMPRESSORS
BASED UPON TEST METHODOLOGIES
ADOPTED BY U.S. EPA AND THE CEC

DECEMBER 1980

U.S. ENVIRONMENTAL PROTECTION AGENCY
OFFICE OF NOISE ABATEMENT AND CONTROL
ANR-490
Washington, DC 20460
USA

COMMISSION OF THE EUROPEAN COMMUNITIES
ENVIRONMENTAL AND CONSUMER PROTECTION SERVICE
200, rue de la Loi
B1049 Brussels
Belgium

FOREWORD

On December 30, 1975, the United States government issued a regulation which set limits on the amount of noise emitted from portable air compressors having flow capacities greater than 75 cfm (0.035 cms). This regulation also specified the noise test procedure to determine the maximum sound pressure level of compressors. On the 5th of April, 1978, the Commission of the European Communities (CEC) submitted a proposed directive to the Council of the European Communities, that also would set limits on the noise emitted by portable air compressors within the European Economic Community (EEC). The proposed directive also specified the test procedure to determine the sound power emitted from a compressor.

It became evident that both U.S. and European manufacturers may need to perform two separate noise tests on their compressors if they intend to meet both the existing U.S. and the proposed EEC noise standards.

At the request of the Compressed Air and Gas Institute, U.S. government representatives entered into discussions with representatives of the Commission of the European Communities (CEC) in November of 1979.

These discussions led to an agreement between the CEC and the U.S. Environmental Protection Agency (EPA) to jointly conduct comparative noise tests of various size compressors to assess the potential for alignment of the existing U.S. and the proposed CEC test procedures.

The test results presented in this report are the end product of those bilateral discussions and technical cooperation between the CEC and the EPA.

CONTENTS

<u>Section</u>	<u>Page</u>
Foreword	i
Acknowledgements	v
1.0. Introduction	1
2.0. Measurement Methods	1
2.1. Common Features	2
2.1.1. Measuring Conditions	2
2.1.2. Instrumentation	2
2.1.3. Installation and Operation of the Compressor	2
2.2. Peculiarities of Each Method	2
2.2.1. EPA Measurement Methodology	2
2.2.2. CEC Measurement Methodology	4
3.0. Comparison of Test Results	6
3.1. Baseline Sound Power Levels	6
3.1.1. Geometric Configuration Adjustment Requisite to Comparison	6
3.2. Specific Results	7
3.2.1. Sound Power Level vs. Number and Location of Microphones	7
3.2.2. Dispersion and Standard Deviation	7
3.2.3. Directivity Indexes	9
3.2.4. Conclusions	10
List of References	11
Figure 1: Instrumentation	12
Figure 2: EPA Microphone Locations to Measure Portable Air Compressors	13
Figure 3: CEC Microphone Array on the Hemisphere	14
Figure 4: Microphone Locations in Horizontal Planes	15

ACKNOWLEDGEMENTS

Acknowledgement is given to the three manufacturers who furnished compressors to the U.S. EPA for comparative testing and to those manufacturers who conducted tests and provided their results to the CEC. Acknowledgement is also given to the Compressed Air and Gas Institute (CAGI) in the United States. Acknowledgement is also given to the European Committee of Manufacturers of Compressors, Vacuum Pumps and Pneumatic Tools (PNEUROP) for their measurement of 12 compressors furnished to the CEC.

A COMPARISON OF SOUND POWER LEVELS FROM PORTABLE AIR
COMPRESSORS BASED UPON TEST METHODOLOGIES ADOPTED BY US-EPA AND THE CEC

1.0. Introduction

This report presents the results of comparative noise measurement tests of portable air compressors. The tests were conducted jointly by the United States Environmental Protection Agency (EPA), the Commission of the European Communities (CEC) and the European Committee of Manufacturers of Compressors, Vacuum Pumps and Pneumatic Tools (PNEUROPE).

The purpose of the tests was to compare noise emission levels from compressors as determined by using the method specified in noise emission standards issued by the US-EPA (1) and, by using the method proposed by CEC (3) based on the measurement procedure adopted by the Council of the European Communities (2).

The subsequent sections describe the comparison tests and present the results of the tests.

2.0. Measurement Methods

In its regulations governing sound emissions from a noise source, the US-EPA specifies levels of sound pressure as the form in which to express measurement results, while the CEC specifies levels of sound power as the form in which to express the measurement results. Thus, the measurement methodologies, and therefore, the test results, designed to determine conformity to existing US and to proposed CEC noise emission standards, differ in a number of ways.

2.1. Common Features

2.1.1. Measuring Conditions

The two methods share the same basic principle in defining the acoustic conditions under which measurements must be made; that is, measurements are made in the free field, conditions free of any acoustical obstructions, over a reflecting plane constructed of non-porous asphalt or concrete. The fact that these basic principles are identical suggests that there should be a good comparison between the results obtained by the two methods.

2.1.2. Instrumentation

The required instrumentation must conform to the standards contained in IEC 179, second edition (4). Two diagrammatic layouts of the basic measurement configurations are illustrated in Figure 1. Both methods require similar calibration of the acoustic instrumentation (4).

Note: The US-EPA regulation specifies that the measurement instruments must conform with standard ANSI-S1.4-1971, equivalent to IEC 179, second edition.

2.1.3. Installation and Operation of the Compressor

The compressor is installed at the center of the test plane and is operated at its full designed speed and rated output flow and pressure. Noise such as that resulting from escaping air must be negligible, i.e., at least 10 decibels (dB) below the noise emitted by the compressor.

2.2. Peculiarities of Each Method

2.2.1. EPA Measurement Methodology

The US-EPA measurement methodology specifies the energy average of the maximum A-weighted sound pressure levels measured at five microphone positions.

This average level is calculated from the following equation:

$$\bar{L}_p = 10 \log_{10} \left[\frac{1}{n} \sum_{i=1}^n 10^{L_i/10} \right] \quad (1)$$

where:

\bar{L}_p = the energy average A-weighted sound level in dB

L_i = the A-weighted sound level in dB at the i th position during a period
not to exceed 15 seconds

n = number of measuring positions = 5

The measurement points are orthogonally located 7 meters from the compressor's five surfaces.

The coordinates of the five measurement points, along the coordinate axes whose origin coincides with the point on the ground below the geometric center of the compressor, are given in Table I below (see also Figure 2):

TABLE I

j	x_j	y_j	z_j
1	$\frac{L}{2} + 7$	0	1.5
2	0	$\frac{W}{2} + 7$	1.5
3	$-\left(\frac{L}{2} + 7\right)$	0	1.5
4	0	$-\left(\frac{W}{2} + 7\right)$	1.5
5	0	0	$H + 7$

where:

L = Length of compressor (m)

W = width of compressor (m)

H = height of compressor (m)

2.2.2. CEC Measurement Methodology

The A-weighted sound power is defined as:

$$L_{WA} = 10 \log_{10} \left[\frac{1}{n} \sum_{i=1}^{i=n} 10^{0.1 L_{pi}} \right] + 10 \log_{10} \left(\frac{S}{S_0} \right) \quad (2)$$

where :

L_{pi} = squared mean of five instantaneous pressure levels recorded at regular intervals not exceeding 15 seconds measured with a sound level meter at point i

S = area of measuring surface (a hemisphere of radius R) (m^2)

S_0 = reference area = $1 m^2$

n = number of measuring points

The radius of the measuring surface and the number of measuring points varies according to the dimensions of the compressor as specified in Table II below:

TABLE II

Length of compressor	Radius of hemisphere	Number of measuring points
L	R	n
$L \leq 1.5 \text{ m}$	4 m	12
$1.5 \text{ m} < L \leq 4 \text{ m}$	10 m	12
$L > 4 \text{ m}$	16	8 (1.5 m above measurement plane)

The coordinates of the 12 measurement points are given in Table III below (see Figure 3):

TABLE III

	x/r	y/r	z/r	z
1	1.00	0	--	1.50 m
2	0.71	0.71	--	1.50 m
3	0	1.00	--	1.50 m
4	-0.71	0.71	--	1.50 m
5	-1.00	0	--	1.50 m
6	-0.71	-0.71	--	1.50 m
7	0	-1.00	--	1.50 m
8	0.71	-0.71	--	1.50 m
9	0.65	0.27	0.71	--
10	-0.27	0.65	0.71	--
11	-0.65	-0.27	0.71	--
12	0.27	-0.65	0.71	--

3.0. Comparison of Test Results

3.1. Baseline Sound Power Levels

Measurements were made of the noise emissions from fifteen different compressors. The sound pressure levels of each were recorded at the microphone positions given by the coordinates in Tables I and III. For the purposes of comparing the sound power levels calculated from pressure levels recorded from the various microphone configurations (A, B, ...I), the levels L_{WA0} determined in accordance with the CEC measurement method (12 measuring points) represent the reference level. This reference point is in concert with the technique utilized by Holmer (5).

The values of \overline{L}_p and L_{WA0} as determined for the 15 compressors are given in Table IV below:

TABLE IV

N ^o	1	2	3	4	5	6	7	8	9	10	11	12	13	14	15
\overline{L}_p	73.1	71.8	73.8	77.5	73.7	72.3	74.7	75.3	73.1	77.7	80.7	82.9	75.6	77.4	75.7
L_{WA0}	98.5	98.8	99.5	104.2	99.7	100.7	101.9	102.3	101.5	103.9	107.5	110.4	101.1	104.3	103.3

Note: The relation of the regression line \overline{L}_p and L_{WA0} is $L_{WA0} = \overline{L}_p + 26.6$

3.1.1. Geometric Configuration Adjustments Requisite to Comparison

To compare the sound power levels determined by the CEC and EPA test procedures, the EPA measured sound pressure levels must be expressed in terms of those levels which would exist on a hemispherical surface surrounding the compressor. The vertical axis of the machine is coincident with the axis of the hemisphere, having a radius of 7 m.

Therefore, the sound power as derived from EPA measurements is given by:

$$L_{WA} = 10 \log_{10} \left[\frac{1}{5} \sum_{j=1}^{j=5} 10^{0.1 L_{pj}} (1 + \frac{k_j}{7})^2 \right] + 25 \quad (3)$$

Note: The value of k_j varies in accordance with the dimension of the compressor as given below:

Measuring point	1	2	3	4	5
k_j	$\frac{L}{2}$	$\frac{W}{2}$	$\frac{L}{2}$	$\frac{W}{2}$	H

where:

L = length of compressor (m)

W = width of compressor (m)

H = height of compressor (m)

3.2. Specific Results

3.2.1. Sound Power Level vs. Number and Location of Microphones

Comparisons were made between the reference (12 measurement points) A-weighted sound power level (L_{WA0}) and the EPA sound power level (L_{WA}) derived from equation 3 and the CEC sound power levels (L_{WA}) calculated from data acquired from the combinations of microphone locations given in Table III. These data are compiled in Table V where different levels are calculated for different microphone locations and configurations as depicted in Table V and represented by letters A through I.

3.2.2. Dispersion and Standard Deviation

The mean dispersion ($\bar{\Delta}$) and the standard deviations (σ) of the sound power levels of the different configurations in relation to L_{WA0} are given in Table VI, assuming for each configuration a normal distribution of the dispersion (Δ).

LWA012	A		B		C		D		E		F		G		H		I	
	L2	Δ	L2	Δ	L2	Δ	L2	Δ	L4	Δ	L4	Δ	L6	Δ	L6	Δ	L5	Δ
98.5	99.6	1.1	95.8	-2.7	98.9	0.4	98.9	0.4	98.1	-0.4	98.9	0.4	98.5	0.0	98.5	0	98.8	0.3
98.8	99.7	0.9	97.8	-1.0	98.8	0.1	99.1	0.3	98.9	-0.0	99.0	0.1	98.6	-0.2	98.9	0.1	97.8	-1.0
99.5	100.5	1.0	98.0	-1.5	99.3	-0.2	100.4	0.9	99.4	-0.1	99.9	0.4	99.6	0.1	99.4	-0.1	100.0	0.5
104.2	106.1	1.8	102.9	-1.3	104.1	-0.2	103.5	-0.7	104.8	0.5	103.8	-0.4	104.8	0.5	103.6	-0.6	103.7	-0.5
99.7	100.5	0.8	99.1	-0.6	100.3	0.6	99.6	-0.1	99.9	0.2	99.9	0.2	99.8	0.1	99.6	-0.1	100.5	0.6
100.7	101.7	1.1	100.0	-0.7	101.1	0.4	101.6	0.9	100.9	0.3	101.3	0.7	100.6	-0.0	100.7	0.0	98.6	-2.0
101.9	101.8	-0.1	100.1	-1.8	102.8	0.9	101.5	-0.4	101.4	-0.5	102.2	-0.3	101.7	-0.2	102.1	0.2	101.0	-0.9
102.3	101.3	-1.0	100.9	-1.4	102.2	-0.1	102.8	0.5	101.1	-1.2	102.5	0.2	102.0	-0.3	102.6	0.3	101.5	-0.8
101.5	101.7	0.2	99.3	-2.2	101.8	0.2	101.8	0.3	100.7	-0.9	101.8	0.2	101.7	0.1	101.5	-0.1	99.7	-1.8
103.9	104.4	0.4	101.5	-2.4	103.3	-0.6	102.8	-1.2	103.2	-0.8	103.0	-0.9	104.1	0.2	103.7	-0.2	104.5	0.6
107.5	105.7	-1.8	106.7	-0.8	105.8	-1.7	104.8	-2.7	106.2	-1.3	105.3	-2.0	108.1	0.6	106.8	-0.7	107.9	0.3
110.4	108.8	-1.5	107.2	-3.1	109.0	-1.4	109.6	-0.7	108.3	-2.1	109.3	-1.0	110.3	-0.1	110.7	0.3	109.1	-1.3
103.6	101.3	-2.2	100.6	-2.9	101.1	-2.5	101.3	-2.2	101.0	-2.6	101.2	-2.4	103.9	0.3	103.2	-0.4	102.7	-0.9
105.4	105.3	-0.2	103.6	-1.8	104.2	-1.2	103.8	-1.6	104.5	-0.9	104.0	-1.4	105.7	0.3	105.3	0.1	104.5	-1.0
103.3	103.6	0.3	101.0	-2.3	103.7	0.4	103.2	-0.1	102.5	-0.8	103.5	0.2	103.2	-0.1	103.4	0.1	101.3	-2.0

TABLE V

TABLE VI

Configuration	A	B	C	D	E	F	G	H	I
$\bar{\Delta}$	0.04	-1.8	-0.4	-0.4	-0.7	-0.4	0.1	-0.1	-0.5
σ	1.2	0.8	0.9	1.1	0.9	1	0.3	0.3	1.0

3.2.3. Directivity Indexes

The directivity index of each compressor is determined for both the CEC 12 microphone and the EPA 5 microphone configuration by using the following formula:

$$DI = L_{pmax} - \overline{L_{pm}} + 3 \quad (D)$$

where:

L_{pmax} = maximum A-weighted sound pressure levels on the measuring surface
(hemisphere of radius R)

$\overline{L_{pm}}$ = mean squared A-weighted sound pressure levels on the measuring surface

The results are given in Table VII below:

TABLE VII

	1	2	3	4	5	6	7	8	9	10	11	12	13	14	15
5 pts EPA	5.3	5.2	5.5	6.0	5.5	5.2	5.1	3.6	5.4	6.6	7.8	6.0	6.6	4.4	5.4
12 pts CEC	4.7	5.3	5.4	6.3	4.9	5.0	5.4	4.6	5.7	5.3	6.7	5.9	8.0	5.7	4.8

3.2.4. Conclusions

The following conclusions can be drawn concerning the material presented in this report:

1. The relationship between the sound power level L_{WA0} as defined in the proposed EEC directive, and the sound pressure level \overline{L}_p as defined in the US-EPA regulation can be described by the following equation

$$L_{WA0} = \overline{L}_p + 26.6$$

with a correlation coefficient greater than 0.9.

This relationship is based upon measurements that have been carried out on 15 air compressors of different sizes.

A review of the data represented in Tables VI and VII shows:

1. The standard deviation for the 2, 4 and 5 microphone configuration is approximately 1 dB. For the 6 microphone configuration, the standard deviation is 0.3 dB.
2. Directivity obviously plays a role in the sound power levels obtained from tests 8, 10, 11, 13 and 14. A review of the sound pressure levels acquired from the 12 measurement microphones indicates that directivity, indeed, exists and the energy is radiated in directions where certain microphone configurations would not measure the total energy. This may be the direct result of the physical location of the air intake and exhaust ports on each individual compressor. Verification of this assumption could be made if the mechanical configuration of each compressor was studied and correlated with the noise level at each microphone location.

List of References

1. Title 40 Part 204: Noise Emission Standards for Construction Equipment (Portable Air Compressors), 41 FR 2162, January 14, 1976.
2. Council Directive of 19 December 1978 on the Approximation of the Laws of the Member States Relating to the Determination of the Noise Emission of Construction Plant and Equipment (79/113/EEC); Official Journal of the European Communities, N^o L 33 of 8 February 1979.
3. Proposal for a Council Directive on the Limitation of the Noise Emitted by Compressors; Official Journal of the European Communities, N^o C 94 of 19 April 1978.
4. IEC Publication 179, second edition, 1973; Precision Sound Level Meters.
5. Procedure for Estimating Sound Power from Measurements of Sound Pressure; Curtis Holmer, NBSIR 75-652; EPA 550/8-76-001.
6. ISO Standard 4872; Measurement of Airborne Noise Emitted by Construction Equipment Intended for Outdoor Use, Method for Determining Compliance with Noise Limits; first edition 1978-06-15.

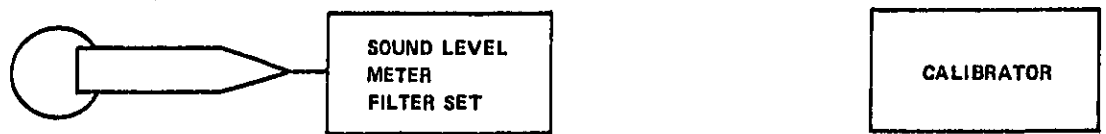
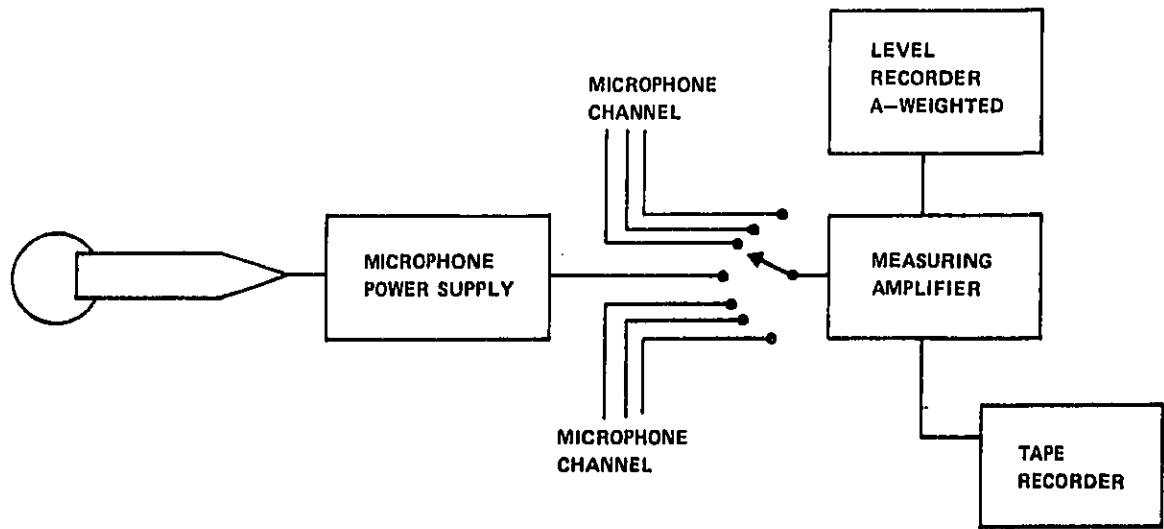

FIGURE 1: Instrumentation

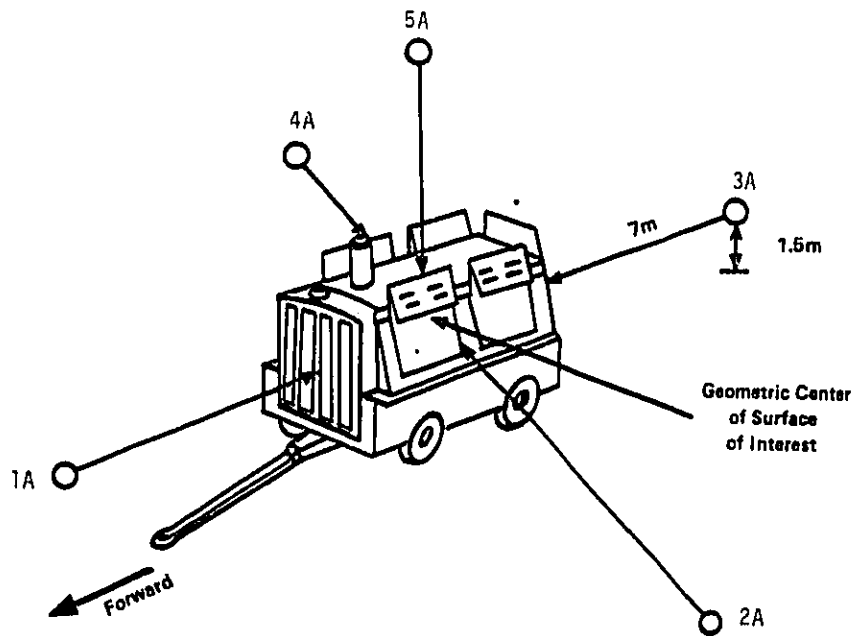

FIGURE 2: EPA Microphone Locations to Measure Portable Air Compressor Noise

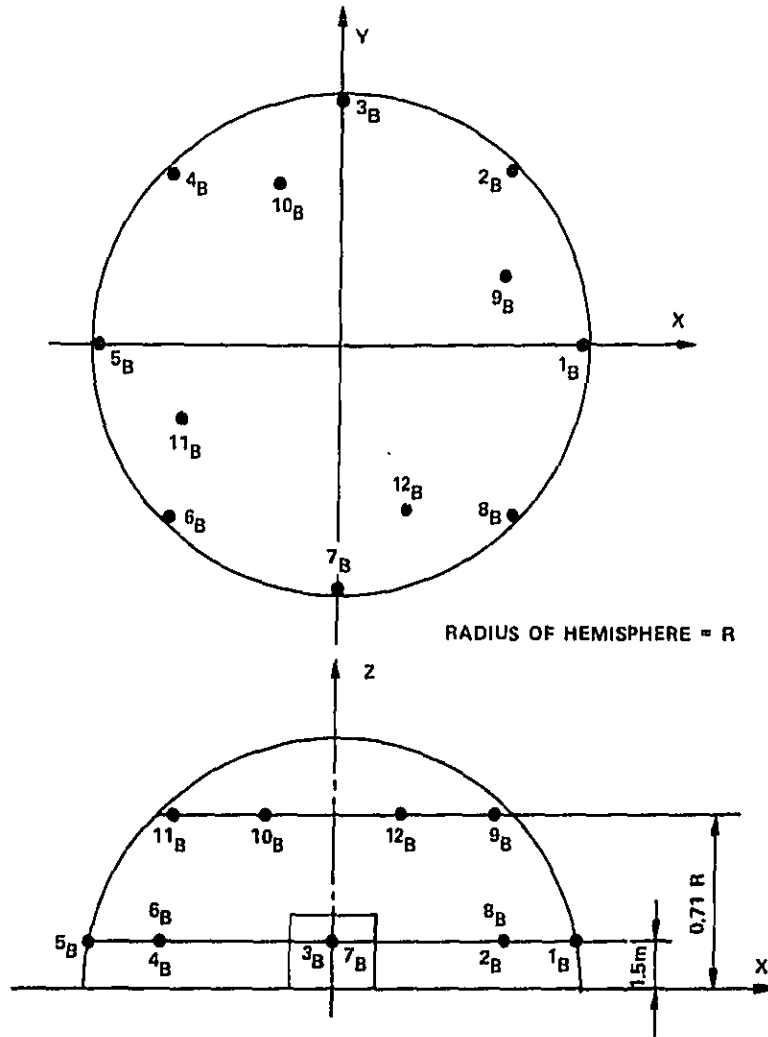

FIGURE 3: CEC Microphone Array on the Hemisphere

EPA: j_A (1A, 2A, 3A...)

CEC: i_B (1B, 2B, 3B...)

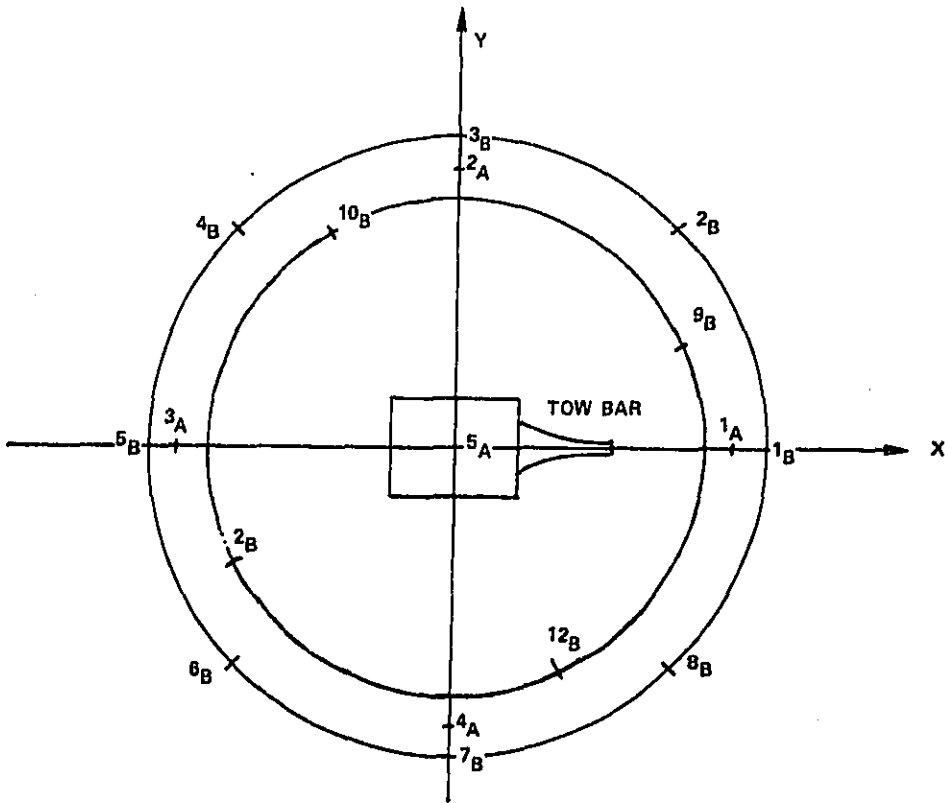

FIGURE 4: Microphone Locations in Horizontal Planes

TECHNICAL REPORT DATA <i>(Please read instructions on the reverse before completing)</i>		
1. REPORT NO.	2.	3. RECIPIENT'S ACCESSION NO.
4. TITLE AND SUBTITLE A Comparison of Sound Power Levels from Portable Air Compressors Based Upon Test Methodologies Adopted By U.S. EPA and the CEC		5. REPORT DATE December 1980
		6. PERFORMING ORGANIZATION CODE EPA/200/02
7. AUTHOR(S)		8. PERFORMING ORGANIZATION REPORT NO.
9. PERFORMING ORGANIZATION NAME AND ADDRESS U.S. Environmental Protection Agency Office of Noise Abatement and Control (ANR-490) Washington, D.C. 20460 AND Commission of the European Communities Environment and Consumer Protection Service 200, rue de la Loi B1049 Brussels Belgium		10. PROGRAM ELEMENT NO.
		11. CONTRACT/GRANT NO.
		13. TYPE OF REPORT AND PERIOD COVERED
		14. SPONSORING AGENCY CODE EPA/200/02
15. SUPPLEMENTARY NOTES		
16. ABSTRACT On December 30, 1975, the United States government issued a regulation which set limits on the amount of noise emitted from portable air compressors. This regulation also specified the noise test procedure to determine the maximum sound pressure level of compressors. On April 5, 1978, the Commission of the European Communities (CEC) submitted a proposed directive to the Council of the European Communities, that also would set limits on the noise emitted by portable air compressors within the European Economic Community (EEC). The proposed directive also specified the test procedure to determine the sound power emitted from a compressor. It became evident that both U.S. and European manufacturers may need to perform two separate noise tests on their compressors if they intend to meet both existing U.S. and the proposed EEC noise standards. At the request of industry, U.S. government representatives entered into discussions with representatives of the CEC in November 1975. These discussions led to an agreement between the CEC and the U.S. EPA to jointly conduct comparative noise tests of various size compressors to assess the potential for alignment of the existing U.S. and the proposed CEC test procedures. The test results presented in this report are the end product of those bilateral discussions and technical cooperation between the CEC and the EPA.		
17. KEY WORDS AND DOCUMENT ANALYSIS		
a. DESCRIPTORS	b. IDENTIFIERS/OPEN ENDED TERMS	c. COSATI Field/Group
Noise emission regulation, portable air compressor, sound power level, sound pressure level, test methodology, EPA, CEC, EEC		
19. DISTRIBUTION STATEMENT Release Unlimited	19. SECURITY CLASS (This Report) Unclassified	21. NO. OF PAGES 24
	20. SECURITY CLASS (This page) Unclassified	22. PRICE

United States
Environmental Protection
Agency

Official Business
Penalty for Private Use
\$300

Washington DC 20460