

N-96-01
II-A-144

APPENDIX C
HIGHWAY CONSTRUCTION NOISE FIELD MEASUREMENTS,
SITE 3: I-95/395 (MARYLAND)

October 1981

Office of Noise Abatement & Control
U. S. Environmental Protection Agency
Washington, D. C. 20460

N-96-01
II-A-144

TECHNICAL REPORT DATA <i>(Please read Instructions on the reverse before completing)</i>		
1. REPORT NO. EPA 550/9-81-314-F	2.	3. RECIPIENT'S ACCESSION NO.
4. TITLE AND SUBTITLE Appendix C, Highway Construction Noise Field Measurements, Site 3: I-95/I-395 (Maryland)	5. REPORT DATE June 1981	6. PERFORMING ORGANIZATION CODE
	8. PERFORMING ORGANIZATION REPORT NO. WR 81-19	
7. AUTHOR(S) William R. Fuller, Ron Brown	9. PERFORMING ORGANIZATION NAME AND ADDRESS Wyle Laboratories/Wyle Research 2361 Jefferson Davis Highway, #404 Arlington, Virginia 22202	
12. SPONSORING AGENCY NAME AND ADDRESS U.S. Environmental Protection Agency, Office of Noise Abatement & Control (ANR-471) Washington, D.C. 20460, and U.S. Department of Transportation, Federal Highway Administration, Washington, D.C. 20590	10. PROGRAM ELEMENT NO.	11. CONTRACT/GRANT NO. DOT-FH-11-9455
	13. TYPE OF REPORT AND PERIOD COVERED Final	
14. SPONSORING AGENCY CODE		
15. SUPPLEMENTARY NOTES Completed under an Interagency Agreement jointly sponsored by both EPA (Office of Noise Abatement and Control) and FHWA.		
16. ABSTRACT <p>This study investigated the noise associated with highway construction activities. It involved the identification and examination of: highway construction activities, noise characteristics associated with highway construction activities, availability of highway construction noise abatement measures, demonstration of construction site noise abatement measures, and development of a computer-based model for use as a tool to predict the noise impact of construction activities and to plan mitigation measures. The model was developed for use on the FHWA computer (IBM 360).</p> <p>A total of seven reports were prepared in this study and have been released for public distribution.</p> <p>Reports (Part D through Part G) contain field data gathered at the field demonstrations at highway construction sites in: Route I-201, California; I-205, Oregon; I-95/I-395, Maryland; and I-75, Florida. They contain noise data on single and multiple pieces of equipment, provide general description of highway site activities, and activity analyses of equipment.</p>		
17. KEY WORDS AND DOCUMENT ANALYSIS		
a. DESCRIPTORS	b. IDENTIFIERS/OPEN ENDED TERMS	c. COSATI Field/Group
Highway Noise Construction Equipment Noise Measurements Construction Noise Noise Abatement		
18. DISTRIBUTION STATEMENT Unlimited	19. SECURITY CLASS (This Report) Unclassified	21. NO. OF PAGES
	20. SECURITY CLASS (This page) Unclassified	22. PRICE

APPENDIX C
HIGHWAY CONSTRUCTION NOISE FIELD MEASUREMENTS,
SITE 3: I-95/395 (MARYLAND)

October 1981

Office of Noise Abatement & Control
U. S. Environmental Protection Agency
Washington, D. C. 20460

This report has been approved by EPA for general availability. The contents of this report reflect the views of the contractor, who is responsible for the facts and the accuracy of the data presented herein, and do not necessarily reflect the official views or policy of EPA or DOT. This report does not constitute a standard, specification, or regulation,

PERMISSION IS GRANTED TO REPRODUCE THIS MATERIAL WITHOUT FURTHER CLEARANCE.

FORWARD

This study was jointly sponsored, through an Interagency Agreement (IAG), by the Office of Noise Abatement and Control (ONAC), U.S. Environmental Protection Agency (EPA), and the Federal Highway Administration (FHWA), U.S. Department of Transportation (DOT). The study was conducted by Wyle Laboratories under contract to FHWA Contract No. DOT-FH-11-9455. Wyle Research of El Segundo, California, and Wyle Research of Arlington, Virginia, performed the study.

The object of the study was to investigate and study the noise associated with highway construction activities. The study involved the identification and examination of: highway construction activities, noise characteristics associated with highway construction activities, availability of highway construction noise abatement measures, demonstration of construction site noise abatement measures, and development of a computer-based model for use as a tool to predict the noise impact of construction activities and to plan mitigation measures. The model was developed for use on the FHWA computer (IBM 360).

The principal project officers for Wyle Laboratories on this project were Mr. William Fuller of Wyle Research in El Segundo and Dr. Kenneth Plotkin of Wyle Research of Arlington, Virginia.

The government project managers for the study were Mr. Fred Romano of FHWA, and Mr. Roger Heymann of EPA/ONAC.

The various technical reports completed by Wyle under this contract and submitted to FHWA have been released for public distribution by EPA.

PREFACE

This study involved a comprehensive review of the environmental noise associated with highway construction activities. A total of seven reports have been released for public distribution. These reports are:

1. Analysis and Abatement of Highway Construction Noise, EPA 550/9-81-314-A, September 1981.
2. A Model for the Prediction of Highway Construction Noise, EPA 550/9-81-314-B, September 1981.
3. IBM 360/System Batch Version of Highway Construction Noise Model, EPA 550/9-81-314-C, September 1981.
4. Appendix A, Highway Construction Noise Field Measurements, Site 1: I-201 (California), EPA 550/9-81-314-D, September 1981.
5. Appendix B, Highway Construction Noise Field Measurements, Site 2: I-205 (Oregon), EPA 550/9-81-314-E, September 1981.
6. Appendix C, Highway Construction Noise Field Measurements, Site 3: I-95/ I-395 (Maryland), EPA 550/9-81-314-F, September 1981.
7. Appendix D, Highway Construction Noise Field Measurements, Site 4: I-75 (Florida), EPA 550/9-81-314-G, September 1981.

The first two reports (Part A and Part B) might be considered the principal reports since they are relatively self-contained units on this study's efforts, the engineering studies and the computer model, respectively. In this regard, if there is to be a limited purchase of the reports, one might consider obtaining either or both of Part A and Part B, and obtaining the other reports as additional informational needs arise.

- The first report (Part A) contains all of the information from the engineering study phase of the project. It gives information on highway construction procedures, highway construction site noise characteristics, available abatement measures, and results from field demonstrations on noise abatement.

- The second report (Part B) presents a complete description of the highway noise prediction model. The report contains a description of the model's formulation and construction, a description of the program, and a user's manual.
- The third report (Part C) provides additional information to the Part B report on the highway construction noise model installed at DOT's Transportation Computer Center on an IBM 360 computer. It delineates the differences between the version of the model as installed on the IBM 360 and the two models (HINPUT and HICNOM) operating on the Wyle Computer (PDP-11). The report has additional user's manual information for use on the IBM 360, a programmer's manual describing changes in going from the PDP-11 to the IBM 360, and a maintenance manual.
- Reports 4, 5, 6, and 7 (Part D through Part G) contain field data gathered at the field demonstrations at highway construction sites in: Route I-201, California; I-205, Oregon; I-95/I-395, Maryland; and I-75, Florida. They contain noise data on single and multiple pieces of equipment, provide general description of highway site activities, and activity analyses of equipment.

APPENDIX C

This appendix summarizes the field measurements performed at the I-95/I-395 (Maryland) construction site during November 1979. Located in the City of Baltimore, this test site was highly typical of highway construction projects in urban, high-density housing areas. The test site actually encompassed four distinct projects in close proximity to each other:

- o I-95
- o I-395
- o I-170
- o "Boulevard" project

A further description of these projects is presented in Section 3.5 of the main report.

The following data and information are presented in this appendix:

1. General highway site description.
2. Noise measurements of activities involving single or multiple pieces of equipment; diagrams describing each activity site are included.
3. Controlled single equipment noise measurements of selected equipment.
4. Equipment activity analysis of selected equipment.

A summary of key construction noise data derived from this site is presented in Section 3.5.3 of the main report.

3-A INTERSTATE & BOULEVARD SYSTEM SUMMARY

Item	Miles	Cost (\$ Millions)
Total 3-A System	81.6	2,789.0
Open to Traffic	17.2	244.9
Under Construction	48.8	487.1
Invited for Bids/ Bids Received	0	0
I.S. Approved - Cleared For Construction	2.8	441.8
I.S. Being Prepared	0.8	114.2

FUNCTIONAL REPLACEMENT PROJECTS

Project	% Completed	Completion Date
1 School No. 178	99%	6-79
2 Central District Police Station	100%	10-77
3 School No. 314	90%	8-79
4 Sharp/Leadenhall Park	50%	9-79
5 Fire House No. 50	Under Design	Adv 7-79/Open 10-80

JOINT DEVELOPMENT PROJECTS

Project	% Completed	Completion Date
6 I-83 Parking Under Viaduct	100%	6-78
7 City Hall Plaza	Under Design	Adv 10-79/Open 11-80
8 Eastwood Park	100%	7-79
9 Park'n Ride	Under Design	Adv 2-80/Open 11-80
10 Golf Driving Range	83%	6-79
11 Ridgely's Delight Park	5%	Summer 1980
12 Hollander Ridge Playground	Under Design	Adv 9-79/Open Summer 1980

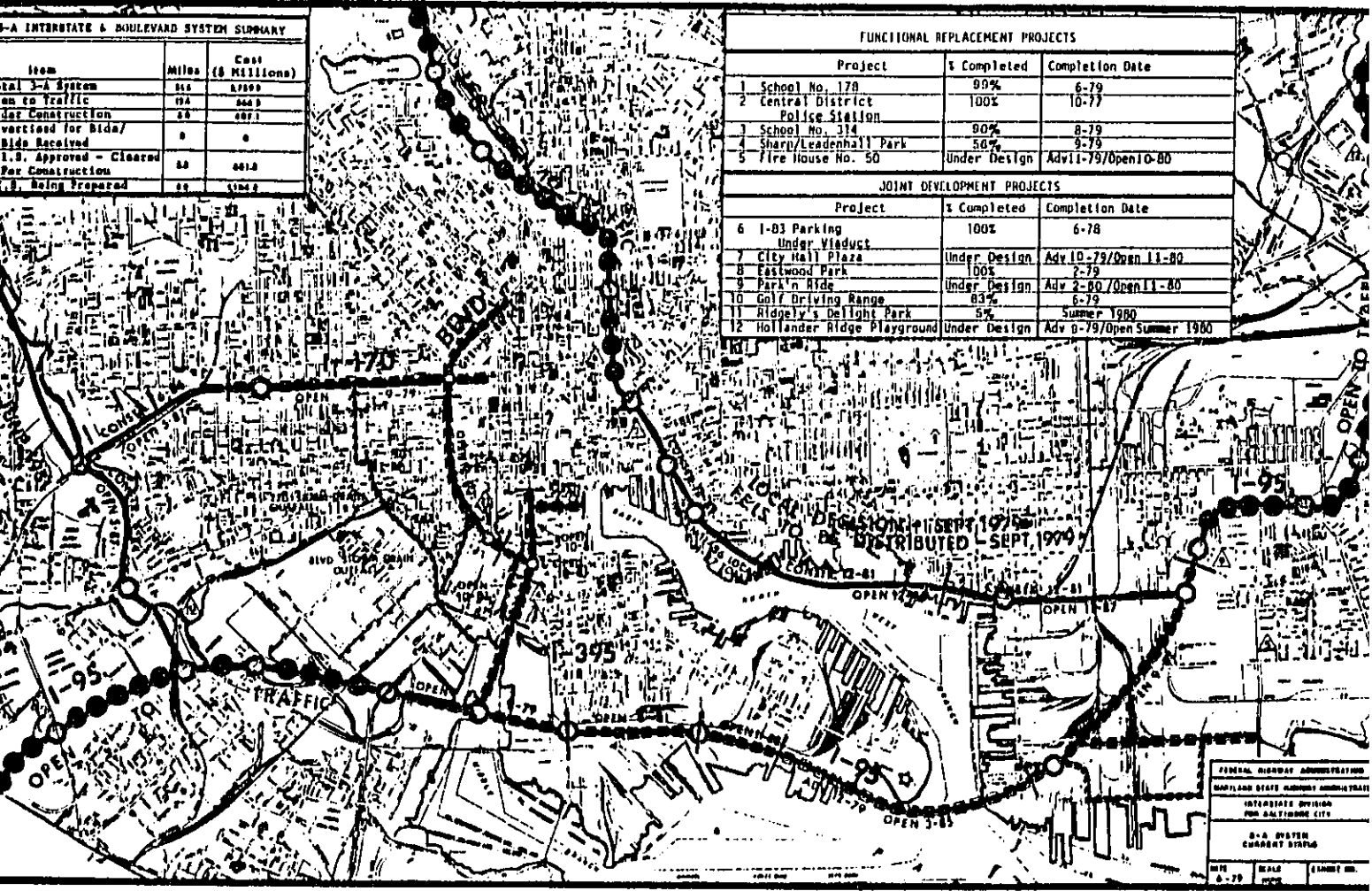

FEDERAL HIGHWAY ADMINISTRATION
 MARYLAND STATE HIGHWAY ADMINISTRATION
 INTERSTATE DIVISION
 FOR BALTIMORE CITY

3-A SYSTEM
 CURRENT STATUS

DATE: 6-79
 SCALE: 1" = 1000'
 SHEET NO.:

Measurement Site Data

Highway: I-95/395

Date: Nov. 1979

Site Location: Fill Area I - Approach ramp to Green St. Overpass (Blvd project)

Type of Measurements:

Community

Activity

Propagation

Site Boundary

Single Equipment

Movies

Soil/Terrain Conditions: Flat terrain; compacted dirt

Machinery Description:

Gradall 6660 Backhoe
Autocar & Mack Single Chassis Dump Trucks
Caterpillar D6 Dozer
Vibratory Roller (Type unknown)
Liebherr Series B, 911 Backhoe

Note: Dump trucks operated at low speed on site

Miscellaneous Information: See diagram for specific equipment location during each recording.

DIAGRAM 11-6A

SUB B-1

BRIDGE EMBANKMENT / APPROACH RAMP

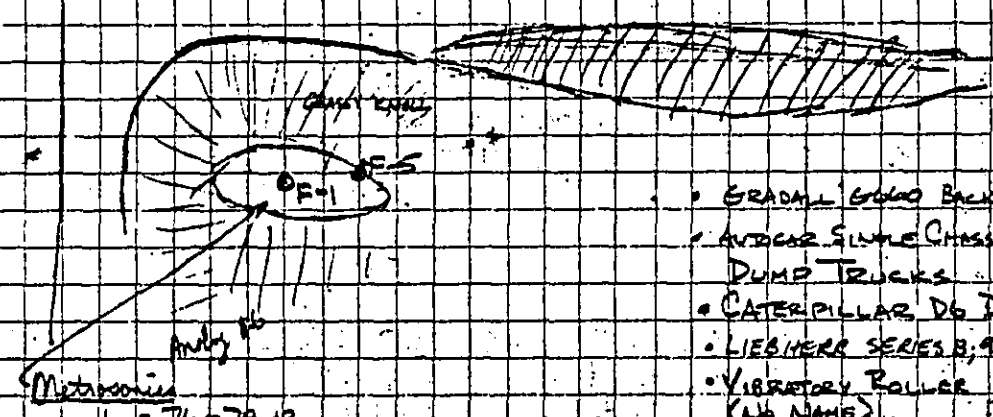
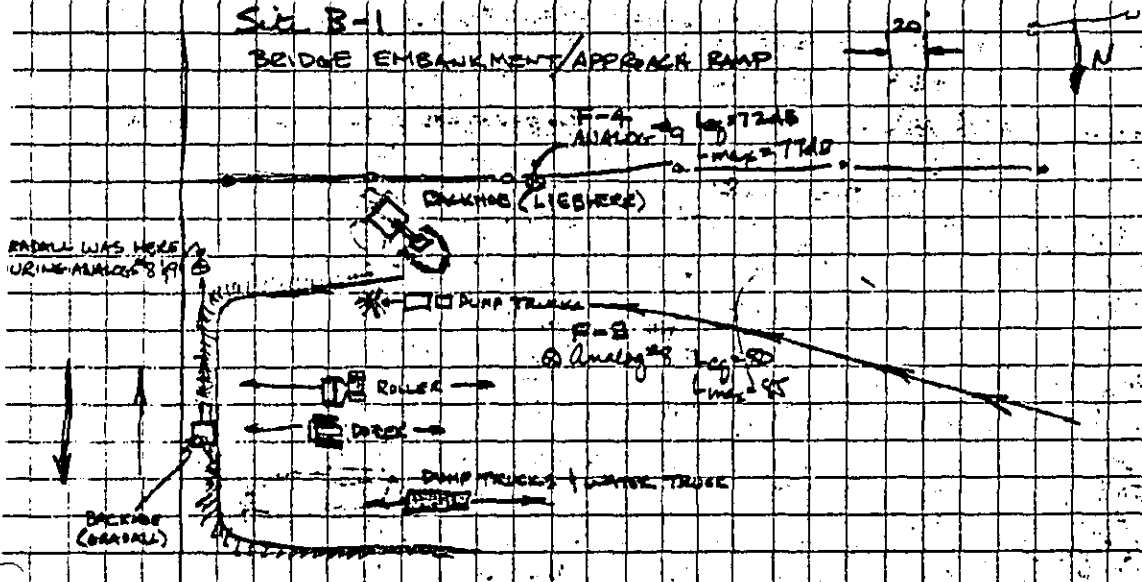

- GRADALL 6000 BACKHOE
- AVDOR SINGLE CHASSIS DUMP TRUCKS
- CATERPILLAR D6 DOZER
- LIEBHERR SERIES 8, 911 BACK
- VIBRATORY ROLLER (L&N H&S)

Metronomic
 $L_A = 76-79$ dB
 $L_{eq} = 79$ dB; S_{min}
 L_{max}

* NOTE: WHEN DIGITAL #1 WAS RECORDED ON 11-7, GRADALL BACKHOE WAS NOT OPERATING

Single Equipment:

GRADALL BACKHOE 220' from side with fan, constant high RPM's $L_{max} = 95-97$ dB
 AVDOR #7 } Roller @ 50' = 88 side, 89 when facing fan
 Dozer @ 50' = 83 side

DIAGRAM 11-6B

(SEE PHOTO)



Seam Autopass
10 inch flaps
Densar Dens 601 @ 1300 RPM



Microphones $L_{max} = 84dB$

DIAGRAM 11-6C



25

Hornlike 3500 Watts, 120 Volt
Resonance Amplifier
(See 5)

Microphones $L_{max} = 92dB$

$L_{eq} = 80dB$ for 2 min

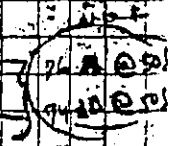
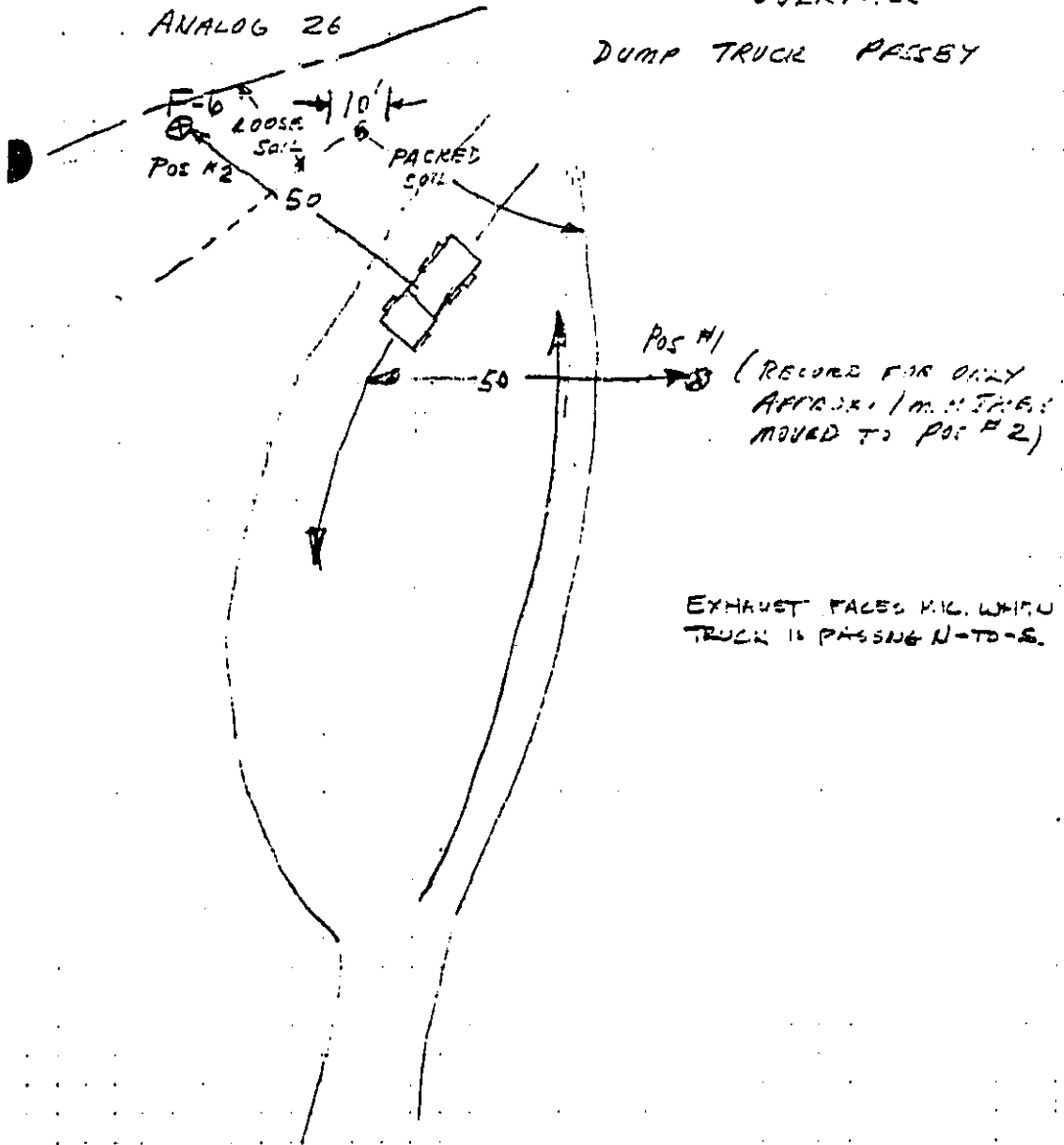

DIAGRAM 11-7D

ANALOG 26

ENTRANCE TO
FILL AREA FOR
OVERPASS

DUMP TRUCK PASSBY



EXHAUST FACES N.W. WHEN
TRUCK IS PASSING N-TO-S.

Measurement Site Data

Highway: I-95/395

Date: Nov 1979

Site Location: Fill Area II - Compaction of
approach ramp fill

Type of Measurements:

Community

Activity

Propogation

Site Boundary

Single Equipment

Movies

Soil/Terrain Conditions: Damp compacted earth

Machinery Description:

Cat 470 Single engine sheep's foot compactor (modified scraper with sheep's foot roller).

Buffalo-Springfield KASE single engine compactor

Miscellaneous Information:

DIAGRAM 11-5B

Modified Scriber
w/ Roller

CAT 470

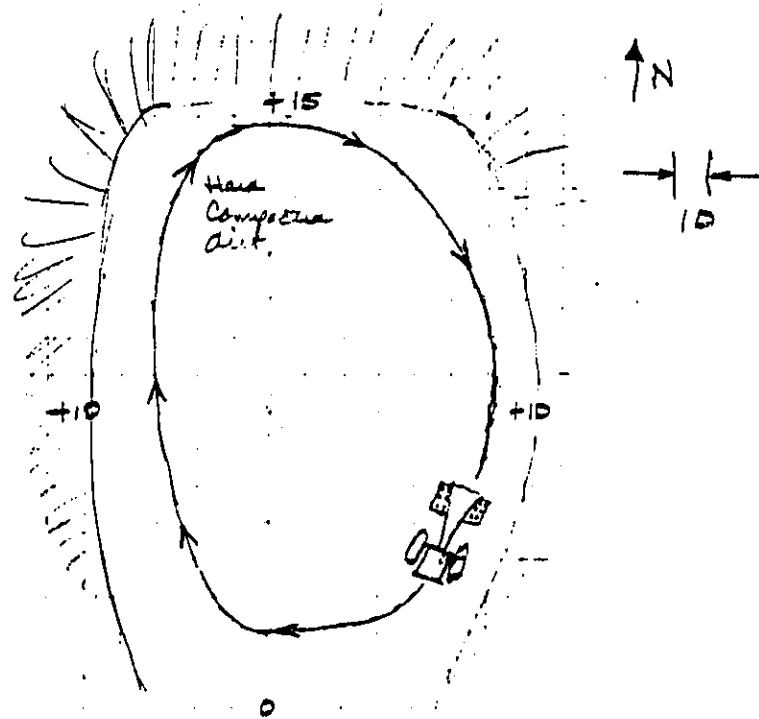

○ F-7
⊗ mic analog #3

DIAGRAM 11-76

APPROXIMATE PAIR
SHEAR'S FOOT PULLING SPAN...
ROLLER K 45B

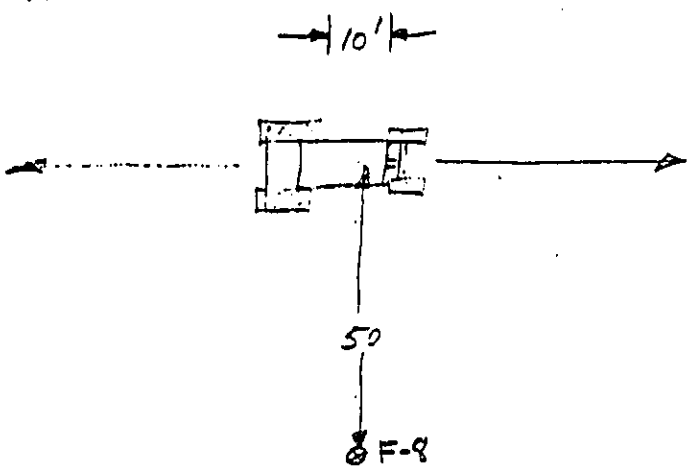

Measurement Site Data

Highway: I - 95/395

Date: Nov. 1979

Site Location: Earthwork Site 1

Type of Measurements:

Community

Activity

Propagation

Site Boundary

Single Equipment

Movie

Soil/Terrain Conditions: Site completed clear of trees, etc.

Approach ramps: skirt along both sides of
right-of-way. Center area of site is relatively
flat terrain. Haul roads are shown on
diagram.

Machinery Description:

Cat 225 Backhoe

Cat 12F Grader

Cat Scraper (Type Unknown)

Cat D6 Dozer

Hydrex Twin-Engine Sheep's Foot Compactor, C450A

John Deere 450C dozer (small)

Miscellaneous Information:

Sample 47-40: at grade with fill operation

47-42: +25 feet above grade

17B-1: +25 feet above grade

ACTIVITY NOISE MEASUREMENTS

HIGHWAY: I-95/395

DATE: Nov. 1979

SITE LOCATION: Earthwork Site I

Sample	Location	Date	Dur.	L _{eq}	L ₉₉	L ₉₀	L ₅₀	L ₁₀	L ₁
47-37	EW-2	11-8	:06	74.6	67	70	73	78	82
-38	EW-3	11-8	:13	83.6	72	73	83	87	87
-39	EW-4	11-8	:11	78.6*	70	71	74	83	87
-40	EW-5	11-8	:15	80.8	69	73	79	85	89
-42	EW-6	11-8	:15	81.8	71	74	80	84	87
-43	EW-7	11-8	:14	84.6	69	70	78	89	93

*SAMPLE INCLUDES FILE DRIVER ACTIVITY; L_{eq} IS MORE REPRESENTATIVE OF SITE BOUNDARY LEVEL THAN HAUL ROAD SITE

DIAGRAM 11-B1E

CAT 225 BACKHOE
 CAT 12F GRADER
 CAT SCRAPERS (UNKNOWN #)
 CAT 12G DOZER
 HYSTER TWIN SHEET FOOT ROLLER CASPA
 (BY CAT 4-CYL DIESEL ENGINE)
 John Deere 850C Dozer (small)

Dental #3 elevated 425'
 Anding #2 elevated 325'

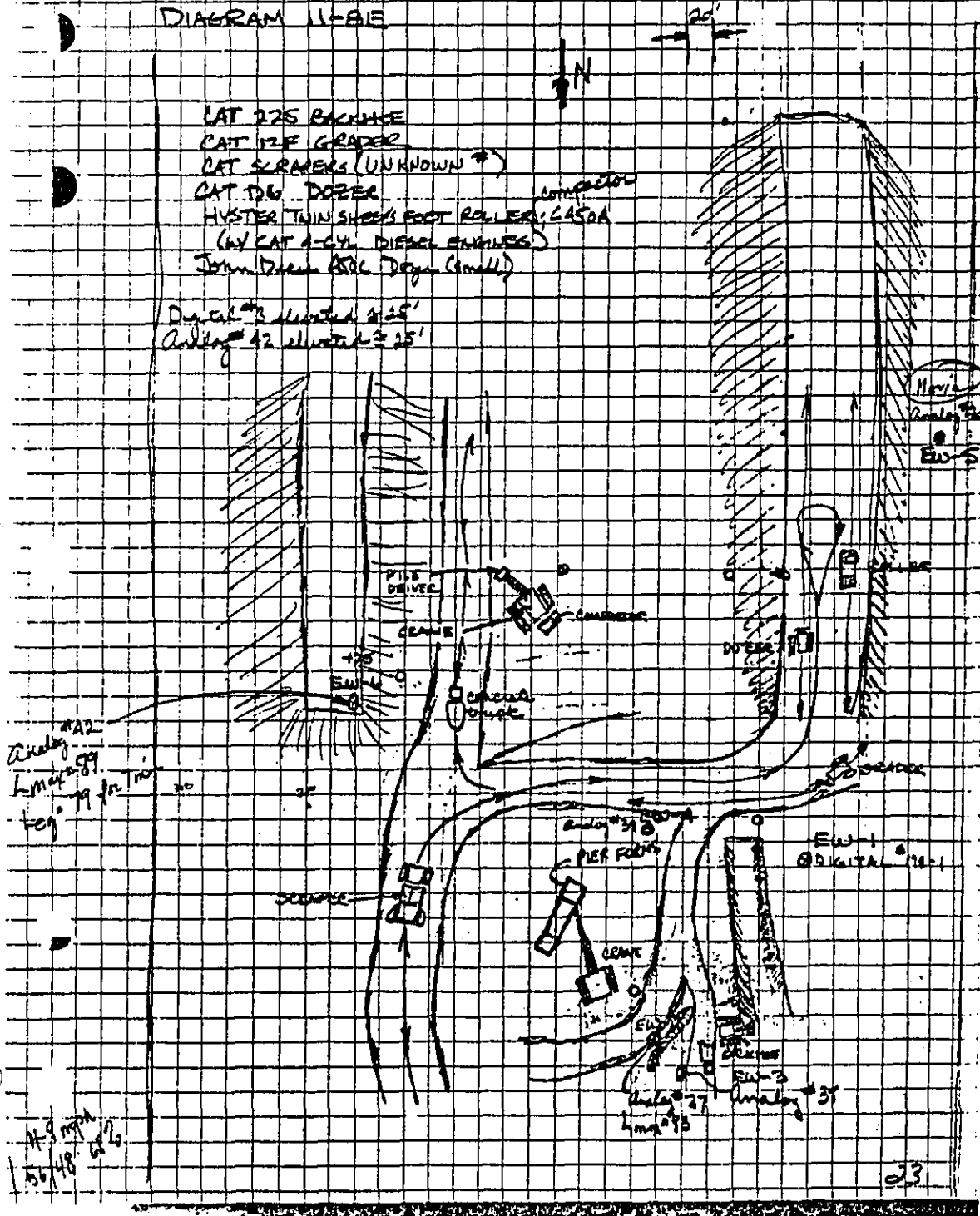
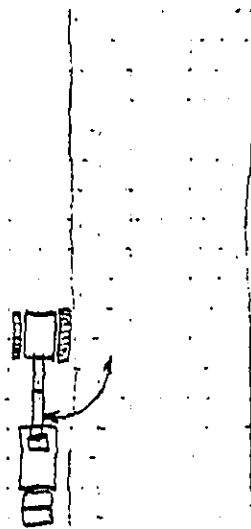

DIAGRAM 11-8F

Cat 225 Backhoe
Mack Dump Truck
w/ Muffler

Analogy #35
⊗
EW-3



10'

DIAGRAM 11-8G SCRAPER PASSBYS

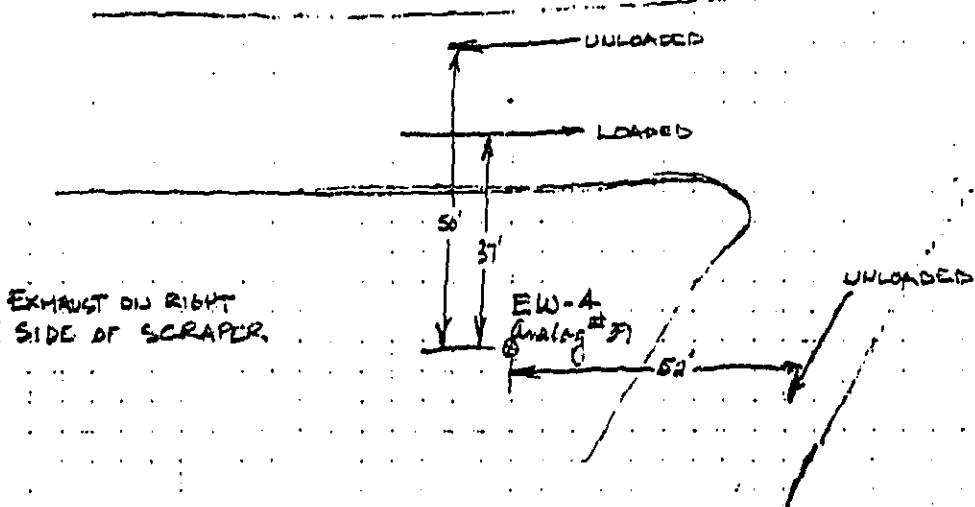

10'

EXHAUST ON RIGHT
SIDE OF SCRAPER.

EW-4
Analogy #37

DIAGRAM 11-BH

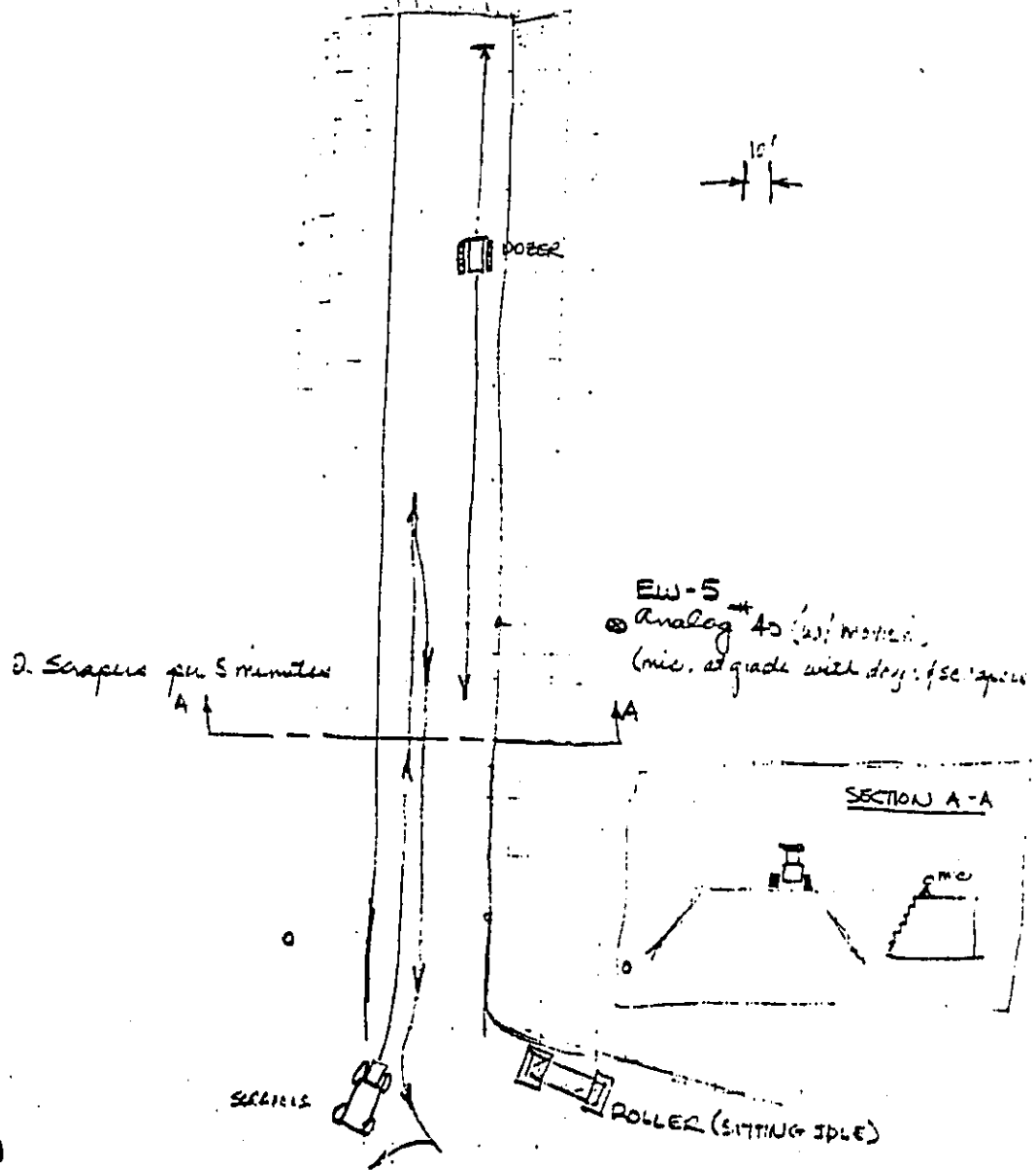

DIAGRAM 11-51

SCRAPERS LOADING
W/ DOZER.

CAT 88H DOZER
CAT SCRAPER'S, OVERLAY

DOSE LIFT

EW-7
DUAL 43
⊗

Leg = 9.5 ft
L max = 9.5 ft



DIAGRAM 11-8J



HYSTER TWIN ENGINE
SHEEPS FOOT COMPACTOR
(SEE PHOTO #15, ROLL #2)

50'

EW-21

Measurement Site Data

Highway: I-95/395

Date: Nov 1979

Site Location: Earthwork Site II; general excavation

Type of Measurements:

Community

Activity

Propagation

Site Boundary

Single Equipment

Movies

Soil/Terrain Conditions: Level, loosely compacted in the vicinity of the microphone; concrete slab 50' from microphone, loose dirt in vicinity of dog

Machinery Description:

Cat 951B Track Loader

Miscellaneous Information:

Loader was working alone, excavating dirt from South end of site and moving to stockpile at North end of site.

DIAGRAM H-SD
CAT 951B TRACK LOADER
SITE EE-1

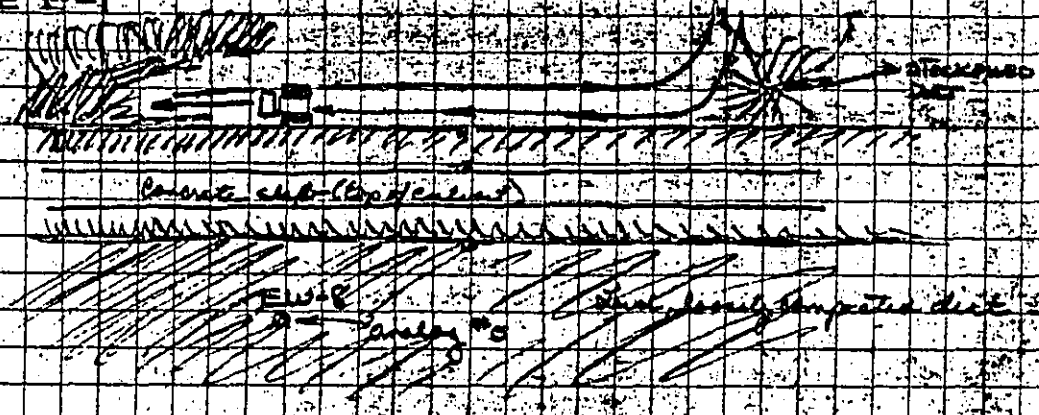

BLACK COPY

30

31

Measurement Site Data

Highway: I-95/395

Date: Nov. 1979

Site Location: Earthwork Site III - Excavation for
box culvert (Blvd. Project)

Type of Measurements:

Community

Activity

Propagation

Site Boundary

Single Equipment

Movies

Soil/Terrain Conditions: Flat, loosely compacted dirt. No
structures within 100' of site.

Note: Dump trucks always operated at low speed on site

Machinery Description:

Kochring 666 Backhoe

Mack Single-Chassis 10-wheel dump trucks

Komatsu DT55 Track Loader

Cat D6C Dozer

Kochring 1066 Backhoe

Bucyrus-Erie 20H Backhoe

Mack Water Truck w/ hand gasoline pump

Miscellaneous Information:

Backhoe was excavating large hole for box
culvert. Backhoe would load truck, then sit while
waiting for next truck.

{ 9 scoops to fill 1 truck; times 5 minutes
{ 3 trucks in 30 minutes

DATA LOG SUMMARY

HIGHWAY: I-95/395

DATE: NOV. 1979

SITE LOCATION: Earthwork Site III

Sample	Location	Date	Time	Dur.	Site Diag.	Comments	Reduced
47-10	EW-9	11-6	1030	:08	11-6D	Barkhoe w/ excavating for brox culvert	✓
- 11	EW-10	11-6	1045	:08	11-6E	Grading work to free stick dog L; one truck passed during sample	✓
- 12*	EW-11	11-6	1100	:07	11-6F	Tract. loader filling dump truck	✓
15B-3	EW-12	11-9	0845	7:05	11-9A	Community measurement; west edge of brox culvert excavation	✓
47-47	EW-13	11-12	N/A	:03	11-12D	Water truck passing; $L_{max} = 95dB @ 22'$	✓

See Earthwork Site IX for comparison w/ different equipment performing similar tasks

DIAGRAM 11-6D

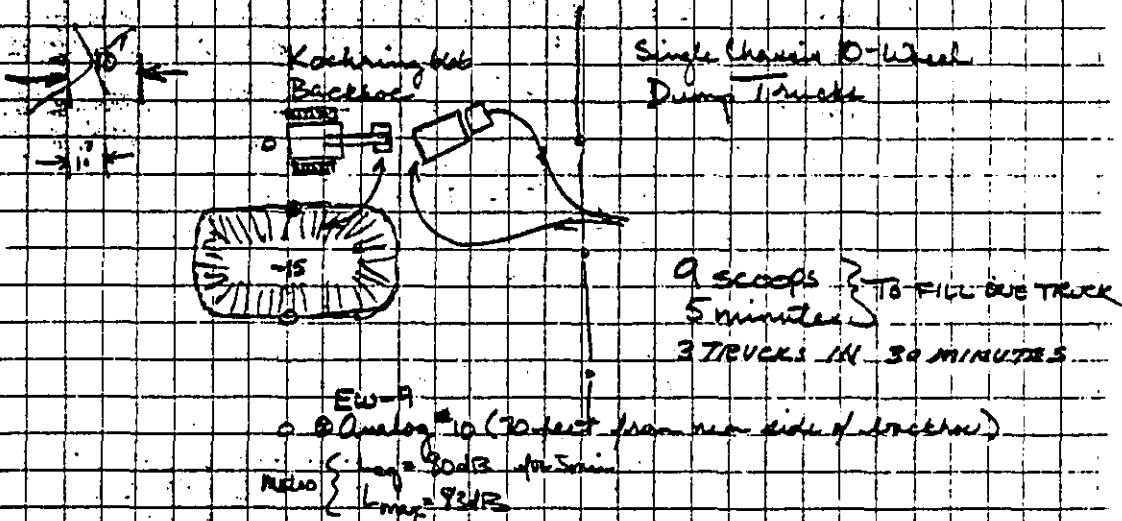

NOTE: L_{max} during idles = 68dB

DIAGRAM 11-9A
 BOY CONVEYER EXCAVATION

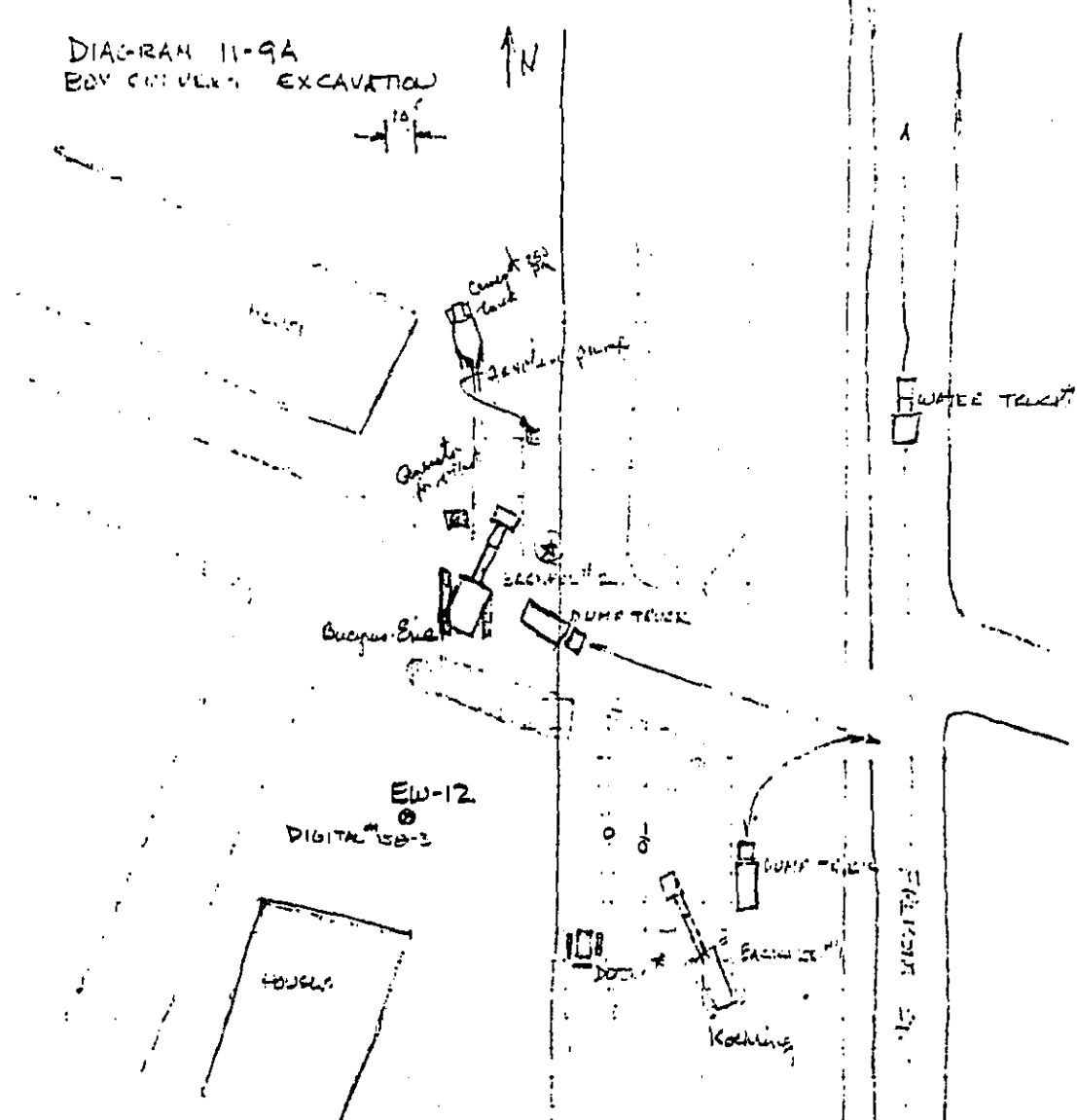

- Backhoe #1: Kohling 1066
- Backhoe #2: Bucyrus-Erie 25-H
- 1100+ Trucks w/ mufflers
- Cat D6C Dozer

* Water truck w/ load pump makes occasional ^{slow} passes on street
 † Dozer not operating when sample was started
 * Several other sources in this area noted at 2:00 PM

DIAGRAM H-12 C WATER TRUCK PASS BY
ANALOG 47

→ 11' ←

← NORTH

PORTLAND ST

S. FREMONT AVE



EW-13

{ 1 truck moving South }
{ 1 pass moving North }

scanned via truck for the
only some interference from
Northbound 9.50 PM

Picture #13

120

MAKING DURING TRUCK
(DIDN'T RUN DURING
RECORDING)

BASK HAE
BUCKYRUS - ERIE 204

DIAGRAM 11-6E

→ N

KOMATSU D755 TRACKLOADER & CAT D6C705

→ 10'

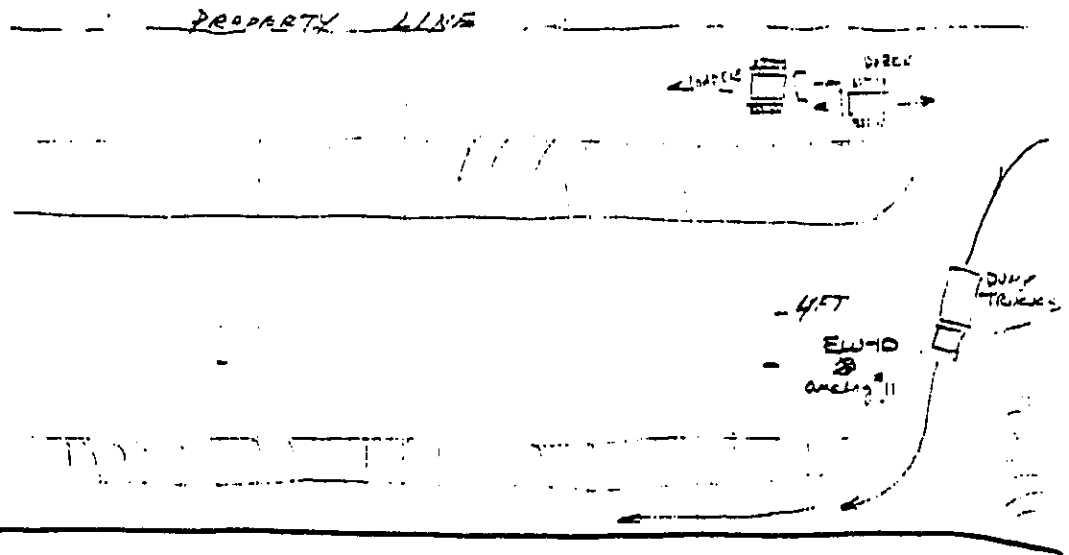
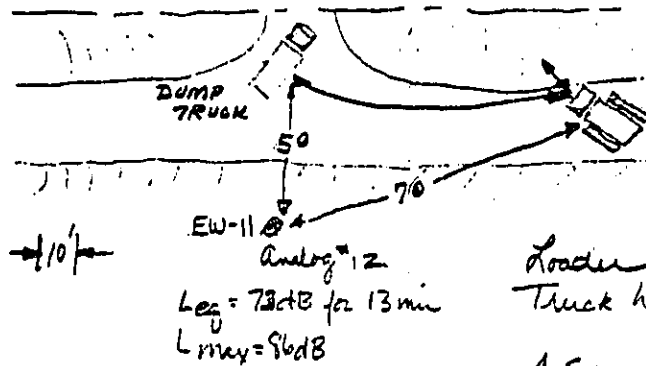

DIAGRAM 11-6F

KOMATSU D755 TRACK LOADER



Loader Scoop Capacity = 3 yds
 Truck hauling Capacity = 14 yds
 4 Scoops to fill each Truck

Measurement Site Data

Highway: I-95/395

Date: Nov. 1979

Site Location: Earthwork Site IV - Trenching
and Pipelaying

Type of Measurements:

Community

Activity

Propagation

Site Boundary

Single Equipment

Movies

Soil/Terrain Conditions: Flat terrain. Buildings approx.
75' east of site

Machinery Description:

1 Kochring 466 Backhoe
1 Cat. 950 Front End Loader
Mack Dump trucks

Miscellaneous Information:

- Front End Loader alternated between loading dirt into trucks (on east side) and filling the trench with gravel (on the west side).
- Backhoe did trenching and pipelaying

DIAGRAM 11-8D

STEM DRAIN TRENCHING
AND PLACEMENT

- | KOEHLING 466 BACKHOE
- | CAT 95C FRONT END LOADER

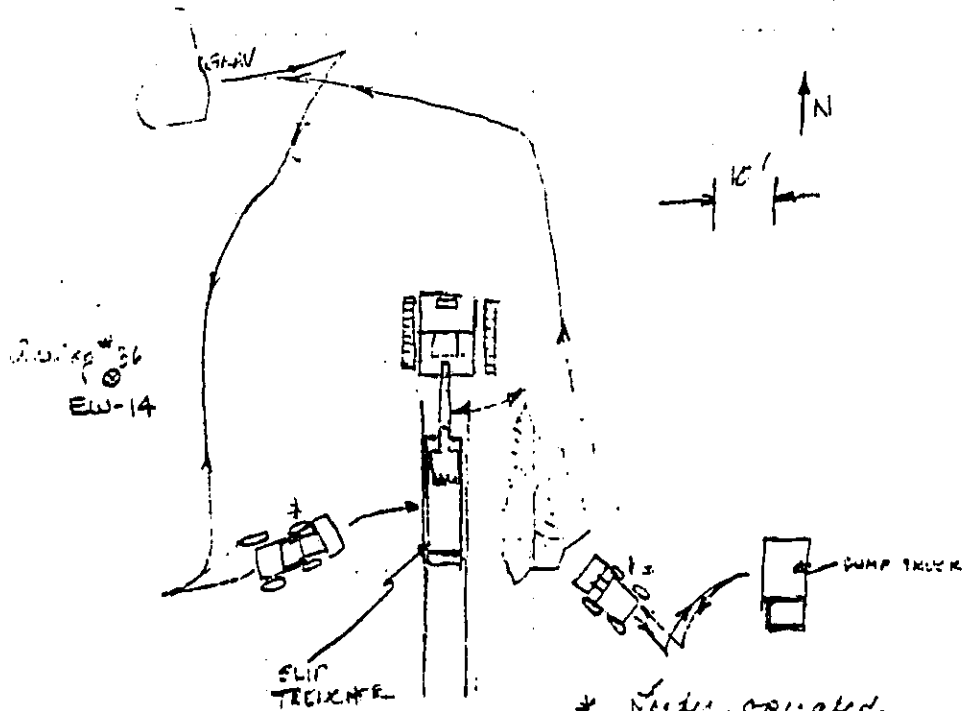

2.5.12.36
EW-14

SLIP
TRENCH

DUMP TRUCK

1-way = 0.5

leg = 79.12. 20 m

* Loader operated
on both sides
of trench

* Backhoe is relatively old

Measurement Site Data

Highway: I-95/395

Date: Nov. 1979

Site Location: Earthwork II - Finish grading next to concrete roadway

Type of Measurements:

- | | | |
|--|--|--------------------------------------|
| <input type="checkbox"/> Community | <input checked="" type="checkbox"/> Activity | <input type="checkbox"/> Propagation |
| <input type="checkbox"/> Site Boundary | <input type="checkbox"/> Single Equipment | <input type="checkbox"/> Movies |

Soil/Terrain Conditions: Level; concrete roadbed between dozer and microphone

Machinery Description:

Cat: D6 Dozer (with degraded muffler)

Miscellaneous Information:

Dozer moved back and forth in front of microphone, leveling loose dirt next to concrete roadbed. Distance of dozer to mic. varied from 50' to 75'

DIAGRAM 11-6I

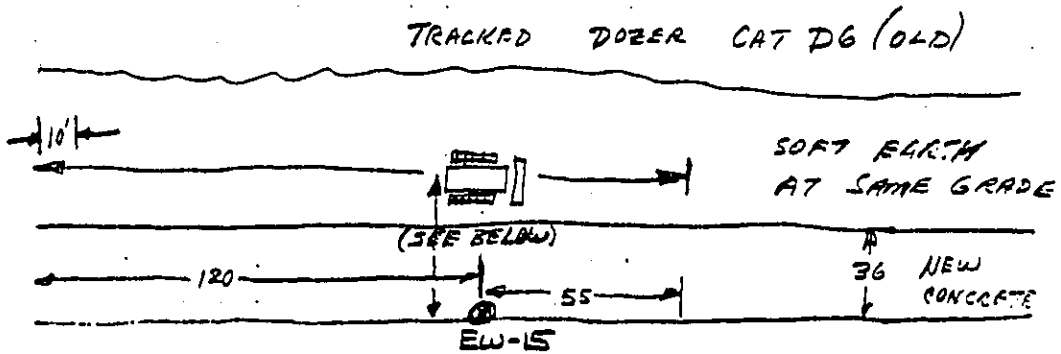

NOTE: DISTANCE VARIED BETWEEN MIC & EQUIPMENT FROM 50' TO 75'

$L_{MAX} = 88$ $L_{eq} = 80$ FOR 7MIN

ANALOG # 16

* SIGNIFICANT TRACK SQUEAL

Measurement Site Data

Highway: I-95/395

Date: Nov. 1979

Site Location: Earthwork Site VI - Concrete Pour
on Box Culvert Structure

Type of Measurements:

- | | | |
|--|--|--------------------------------------|
| <input type="checkbox"/> Community | <input checked="" type="checkbox"/> Activity | <input type="checkbox"/> Propagation |
| <input type="checkbox"/> Site Boundary | <input type="checkbox"/> Single Equipment | <input type="checkbox"/> Movies |

Soil/Terrain Conditions: _____

Machinery Description:
Mack DM-600 Concrete Trucks with
straight stacks
Concrete conveyor using 4-cylinder engine
Small gasoline generator powering a concrete
vibrator

Miscellaneous Information:

DIAGRAM 11-6J

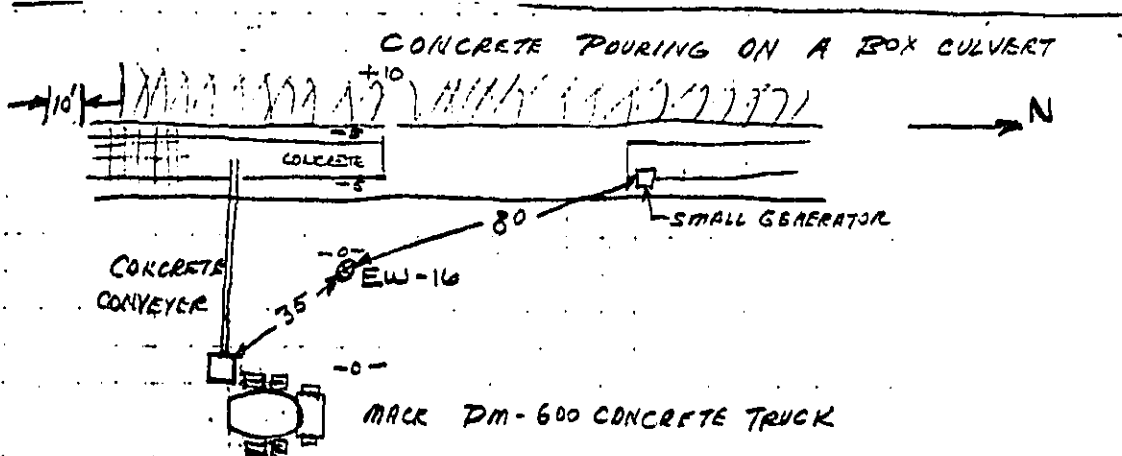

Lmax = 84 Leg = 77 FOR 6 MINUTES
 ANALOG #17

NOTE: THE MUFFLER FROM 4CYL ENGINE OF THE CONCRETE CONVEYER WAS POINTED DIRECTLY AT THE MICROPHONE

Measurement Site Data

Highway: I-95/395

Date: Nov. 1979

Site Location: Earthwork Site VII - Backfilling a
culvert using backhoe

Type of Measurements:

Community

Activity

Propagation

Site Boundary

Single Equipment

Movies

Soil/Terrain Conditions: Flat terrain, cleared of all
trees, etc.

Machinery Description:

Cat. 225 Backhoe

Miscellaneous Information:

DIAGRAM 11-7H

ANALOG 30

BACK HOE CAT 225
BACK FILLING OF CULVERT

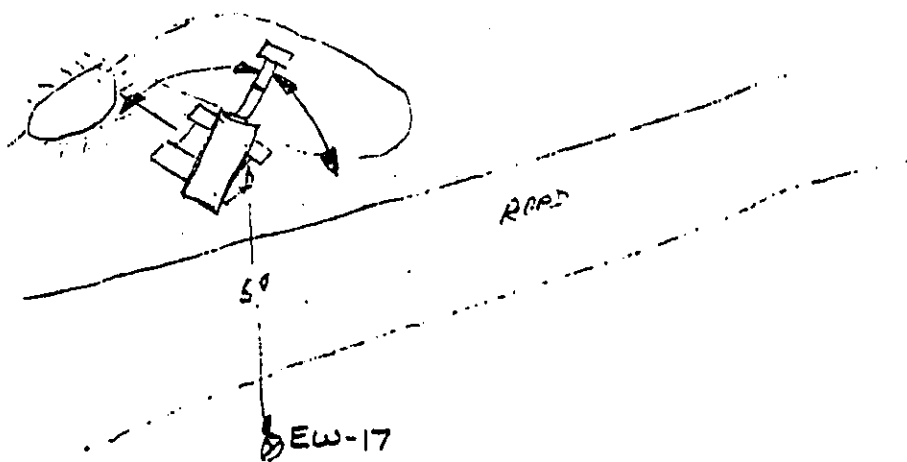

Measurement Site Data

Highway: I-95/395

Date: Nov. 1979

Site Location: Earthwork Site VIII - Backhoe digging
trench for drainage pipe

Type of Measurements:

- | | | |
|--|--|--------------------------------------|
| <input type="checkbox"/> Community | <input checked="" type="checkbox"/> Activity | <input type="checkbox"/> Propagation |
| <input type="checkbox"/> Site Boundary | <input type="checkbox"/> Single Equipment | <input type="checkbox"/> Movies |

Soil/Terrain Conditions: Relatively flat area along
Blud. project site boundary. High-rise
apartment adjacent to measurement site

Machinery Description:

P & H Backhoe (model # unknown)

Miscellaneous Information:

DIAGRAM 11-6K

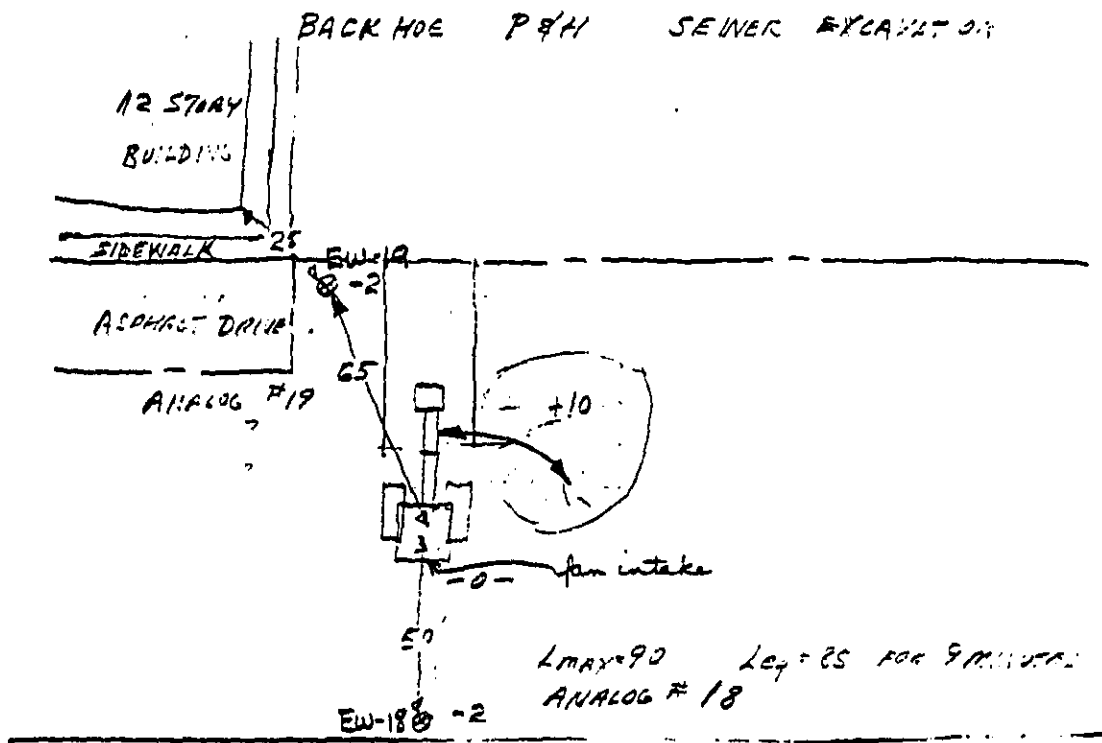

Measurement Site Data

Highway: I-95/395

Date: Nov. 1979

Site Location: Earthwork Site IX - Loading of
demolished pavement for transport

Type of Measurements:

Community

Activity

Propagation

Site Boundary

Single Equipment

Movies

Soil/Terrain Conditions: Flat terrain

Machinery Description:

Cat 983 track loader

Mack Single Chassis dump truck with straight
stack

Miscellaneous Information:

DIAGRAM 11-12B PRELIMINARY LAYOUTS AT
 ANALOG 46 1102 AREA FOR BLVD 35 RAMP

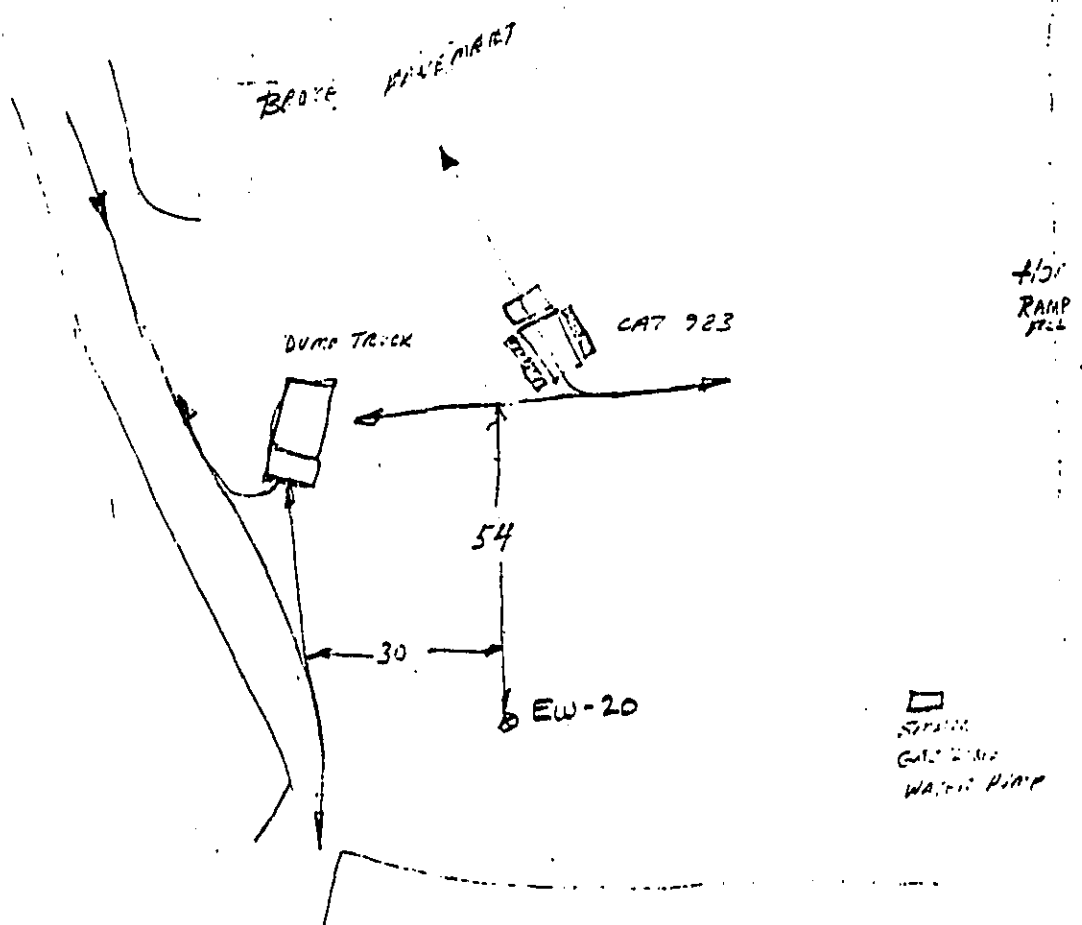

MICROSONICS
 L_{MAX} = 89 Log = 74 FOR 5 MIN.

62

Measurement Site Data

Highway: I-95/395

Date: Nov. 1979

Site Location: Paving Site I - Single lane concrete
paver

Type of Measurements:

Community

Activity

Propagation

Site Boundary

Single Equipment

Movies

Soil/Terrain Conditions: 2 lanes of concrete exist between
paver and microphone; small embankment directly
in front of mic.

Machinery Description:

Blaw-Knox Single lane paver
Mack Concrete Trucks with straight stock.

Miscellaneous Information:

DIAGRAM 11-6H

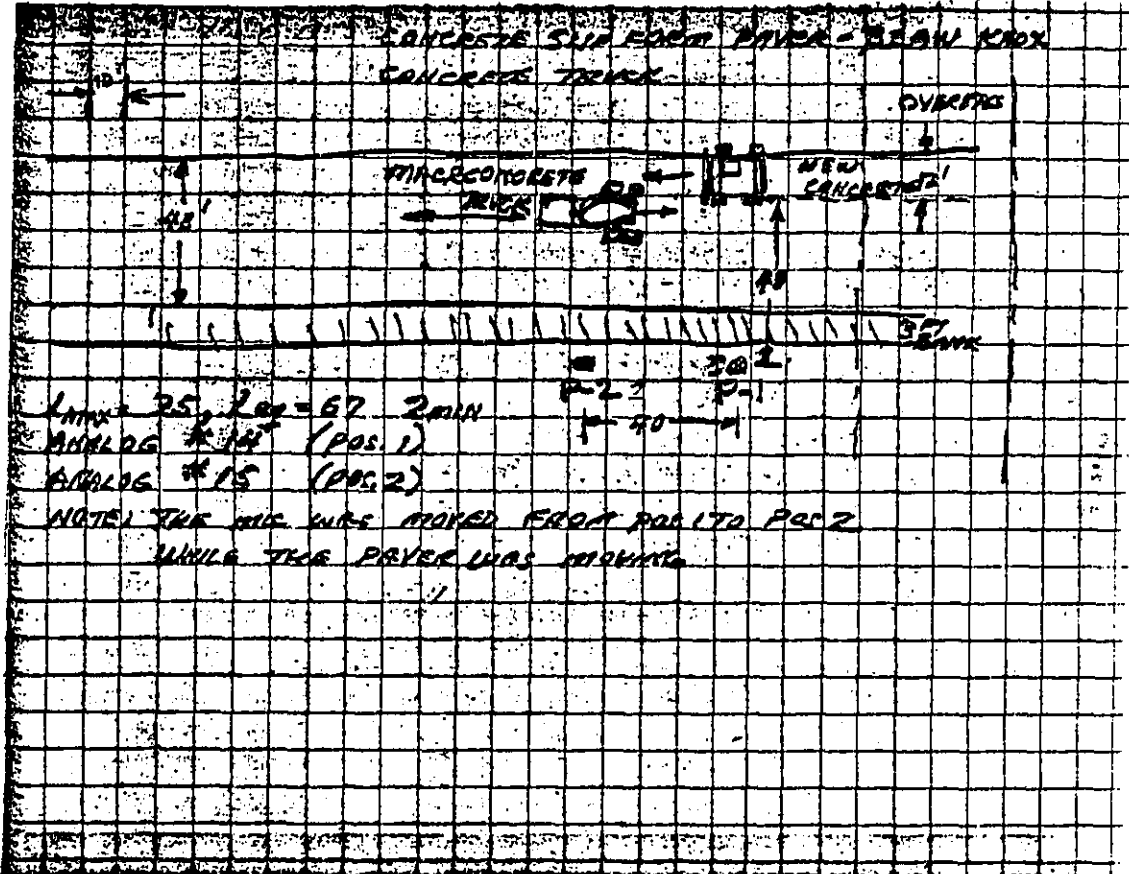

Measurement Site Data

Highway: I-95/395

Date: Nov. 1979

Site Location: Paving Site II - Asphalt paving

Type of Measurements:

Community

Activity

Propagation

Site Boundary

Single Equipment

Movies

Soil/Terrain Conditions: Flat paved surfaces in vicinity
of microphone

Machinery Description:

Barber-Greene Asphalt Spreader
Dynapac 42A Vibratory Roller (dual rollers)
Mack dump-trucks with mufflers

Miscellaneous Information:

1. First run of spreader: 40 ft. from mic.
2. Second run of spreader: 52 ft from mic. (backing)
3. Roller made passes at various distances from 34 to 43 feet from mic.

DIAGRAM 11-12D ASPHALT PAVING - BLVD. NORTH
 ANALOG 48

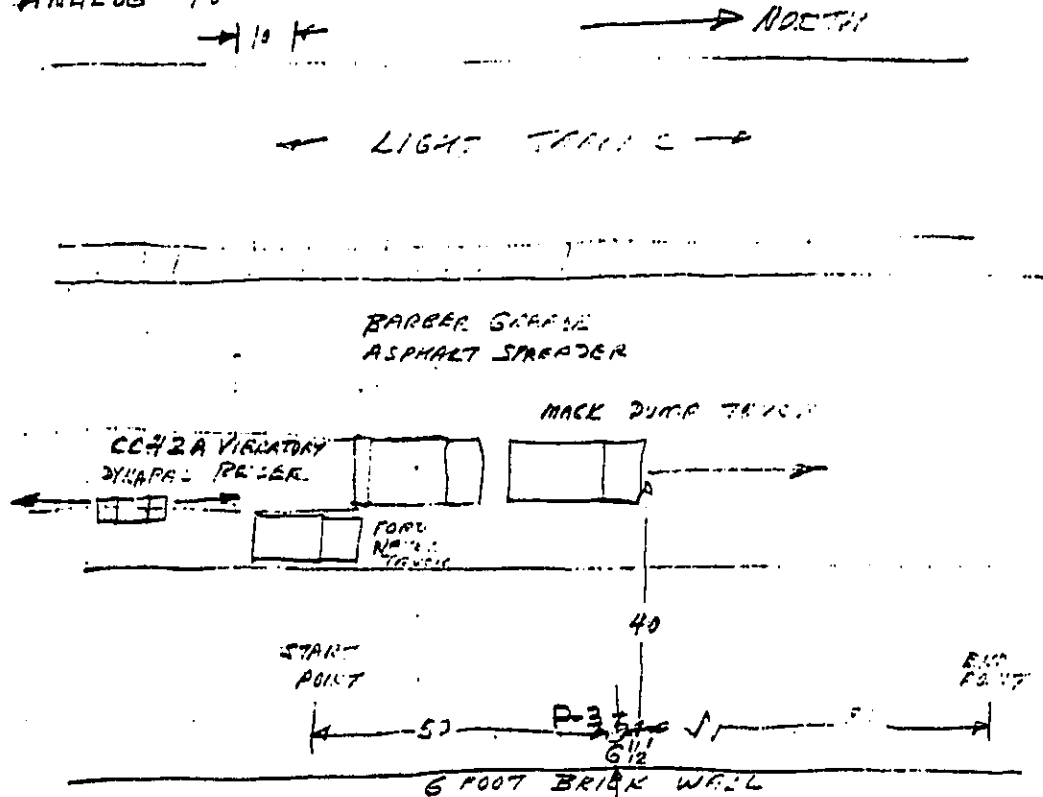

Distances 118' 1/2, 16' (Roller)

- NOTE:
1. Find run of spreader at 40 feet
 2. Also find run of spreader at 5 1/2 feet
 3. THE ROLLER WINDS PASSES AT VARIOUS DISTANCES FROM 34 TO 43 FEET FROM THE WALL

Measurement Site Data

Highway: I-95/395

Date: Nov. 1979

Site Location: Bridge Site I - Demolition of
concrete slab; pile driving

Type of Measurements:

Community

Activity

Propagation

Site Boundary

Single Equipment

Movies

Soil/Terrain Conditions: Flat terrain; loosely compacted,
damp soil.

Machinery Description:

- 2 Ingersoll-Rand "Whisperized" 185 CFM Compressors
- 2 Chicago-Pneumatic 80-pound jackhammers
- 1 Fumetractor H-8 w/ pneumatic breaker mounted on the rear
- 1 Crane-mounted pile driver

Miscellaneous Information:

DIAGRAM II-SA

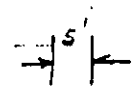

B-2

Analogy #2 (30' from rear of site / compressor)

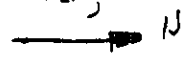

Site D-1

Demolition of Concrete Slab

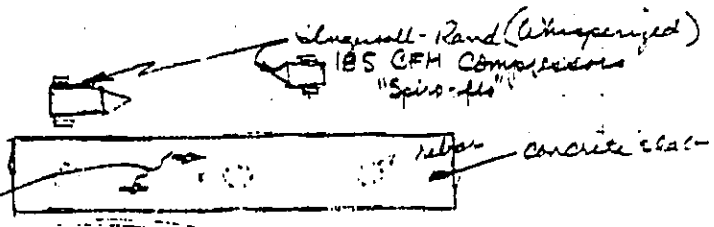

2 jacks

(Backhoe operating 130' behind mic.)

loosely compacted dirt and sand

B-1

mic. analogy #1 (50' from jacks)

DIAGRAM 11-7E
SITE D1

CONCRETE FOUNDATION REMOVAL
WITH JACK HAMMERS & PNEUMATIC HAMMER

APRIL 06 '27

→ 18' h ←

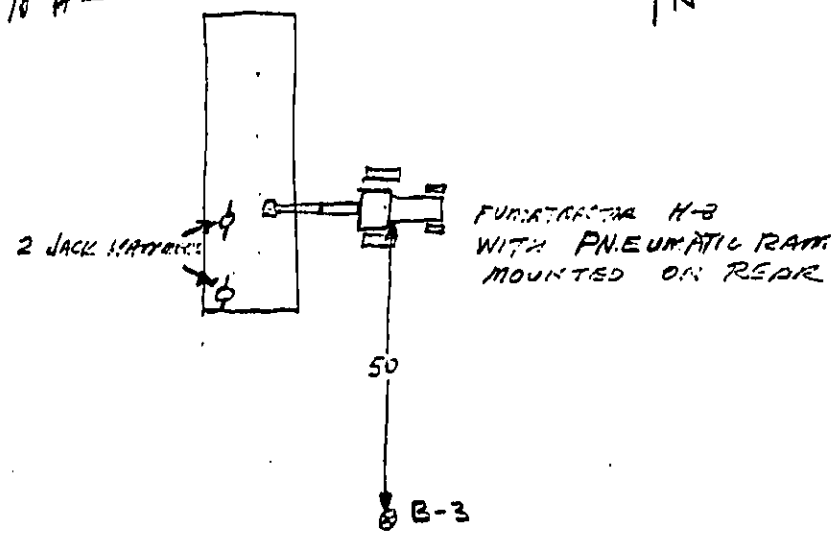

MICROSON ... Lmax: 40

PILE DRIVER : 49 IMPACTS PER MINUTE

ANALOG #20
L MAX = 83
Leg = 83
FOR 8 MIN

COBBLESTONE
STRAP

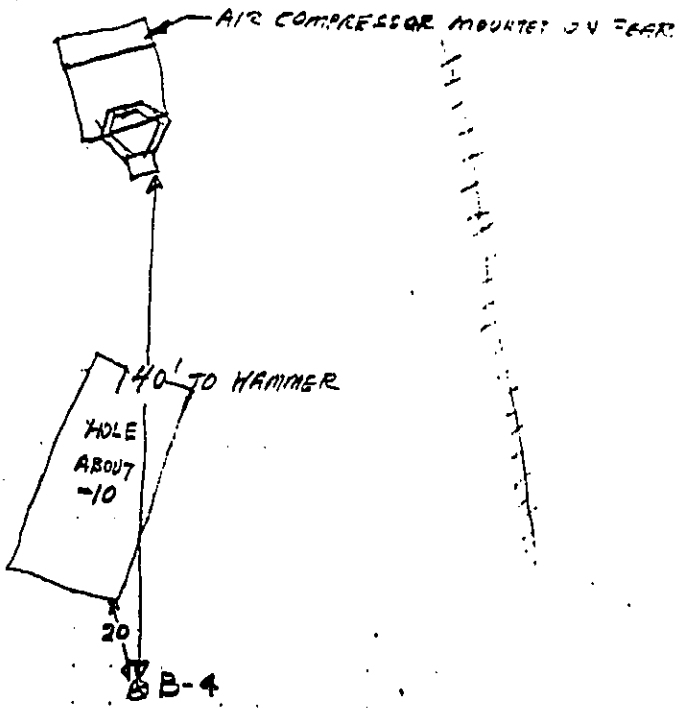
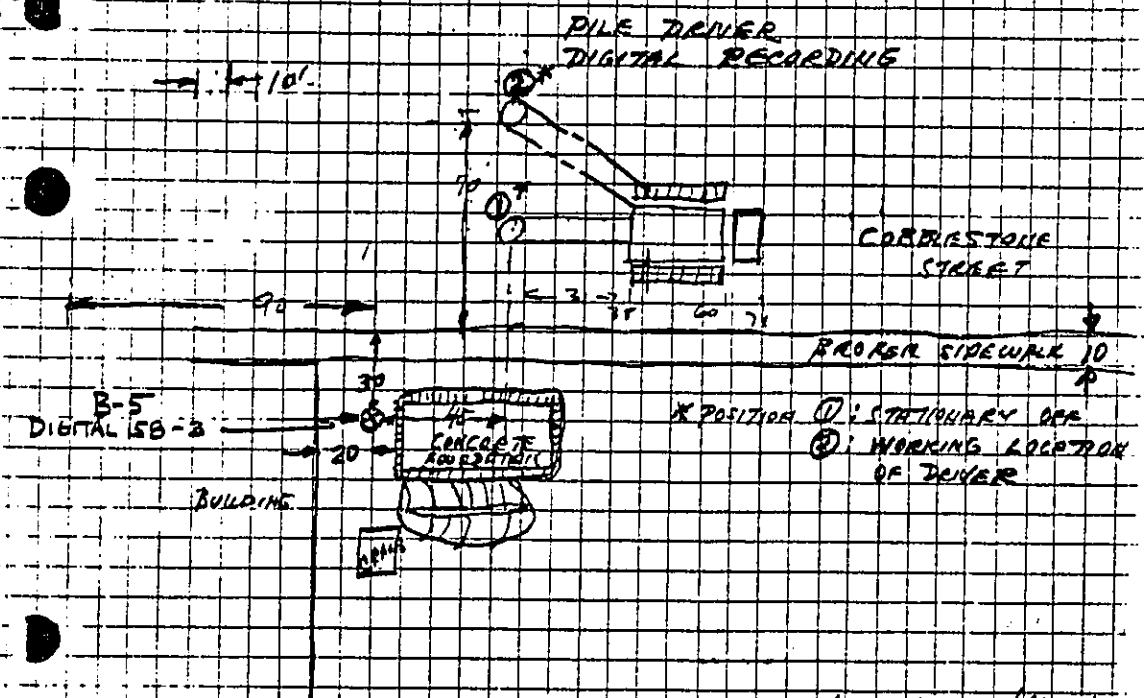

DIAGRAM 11-88



NOTE: PILE DRIVER START UP AT 9:35 A.

0945 large drive still not working a crane moving work from from area of concrete foundation

Measurement Site Data

Highway: I-95/395

Date: Nov. 1979

Site Location: Bridge Site II - bridge pier at site
span

Type of Measurements:

Community

Activity

Propagation

Site Boundary

Single Equipment

Movies

Soil/Terrain Conditions: Flat terrain; street bordered
north edge of site. 3-story building along
west edge of site

Machinery Description:

Kochring 665 heavy crane
Case 580C Tractor with tamper
Mack cement trucks w/ straight stacks
Cement vibrator w/ generator

Miscellaneous Information:

Cement trucks would pull onto the site, then mix their load of cement. Truck would then pull into position, load concrete into concrete bucket. Crane would lift bucket to the top of pier formwork. Vibrator was operated while concrete was being poured.

DIAGRAM 11-8 C CONCRETE POURS
 ANALOG 33
 METROSOURCE L MAX 80 Leg 75 FOR 22 MIN
 H.O.

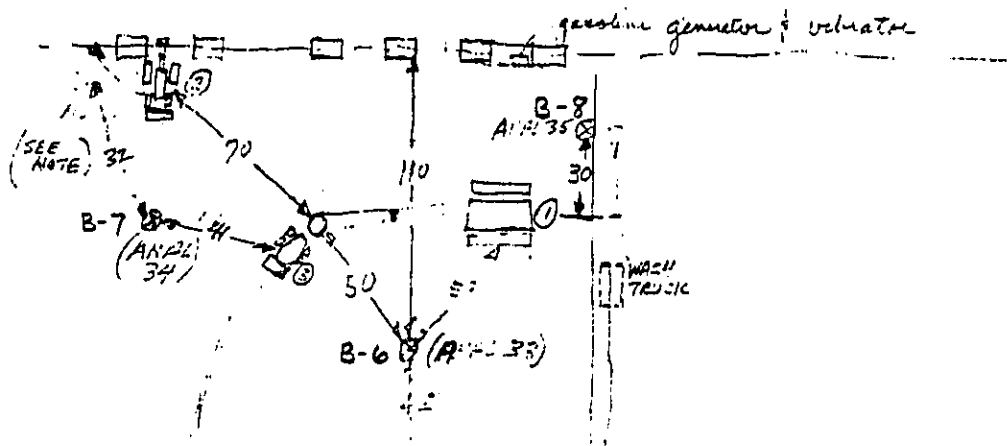

- EQUIPMENT:
1. KOBELCO'S 665 TRACKER
 2. CAT'S 580A TRACKER WITH TAMPER
 3. MACK CEMENT TRUCK WITH 5000 GALS. TANK

ANALOG 34
 METROSOURCE L MAX 89 Leg 25 FOR 12 MIN

- NOTES:
1. TRACTOR WAS POSITIONED TO LEFT OF SUPPORTED FROM MINE
 2. TRACTOR THEN MOVED TO RIGHT OF MINE APPROX 15' FROM MINE, THE TAMPER WAS APPROX 30' FROM MINE
 3. THE CONCRETE TRUCK DID NOT STOP TO WASH

ANALOG 35
 METROSOURCE L MAX 88 Leg 76 FOR 14 MIN

- NOTES:
1. TRACKER DOZER STARTED WORKING TO IMPROVE WORK SITE

WEATHER 10:50a WIND 3-5 S AIR 49 TO 72

Measurement Site Data

Highway: I - 95/395

Date: Nov. 1979

Site Location: Bridge Site III - Steel girder erection

Type of Measurements:

Community

Activity

Propagation

Site Boundary

Single Equipment

Movies

Soil/Terrain Conditions: _____

Machinery Description:

2 P & H Heavy duty cranes
1 Heavy truck tractor/trailer carrying
steel girder

Miscellaneous Information:

DIAGRAM 11-9C
OVERHEAD STEEL CONSTRUCTION

↑
NORTH

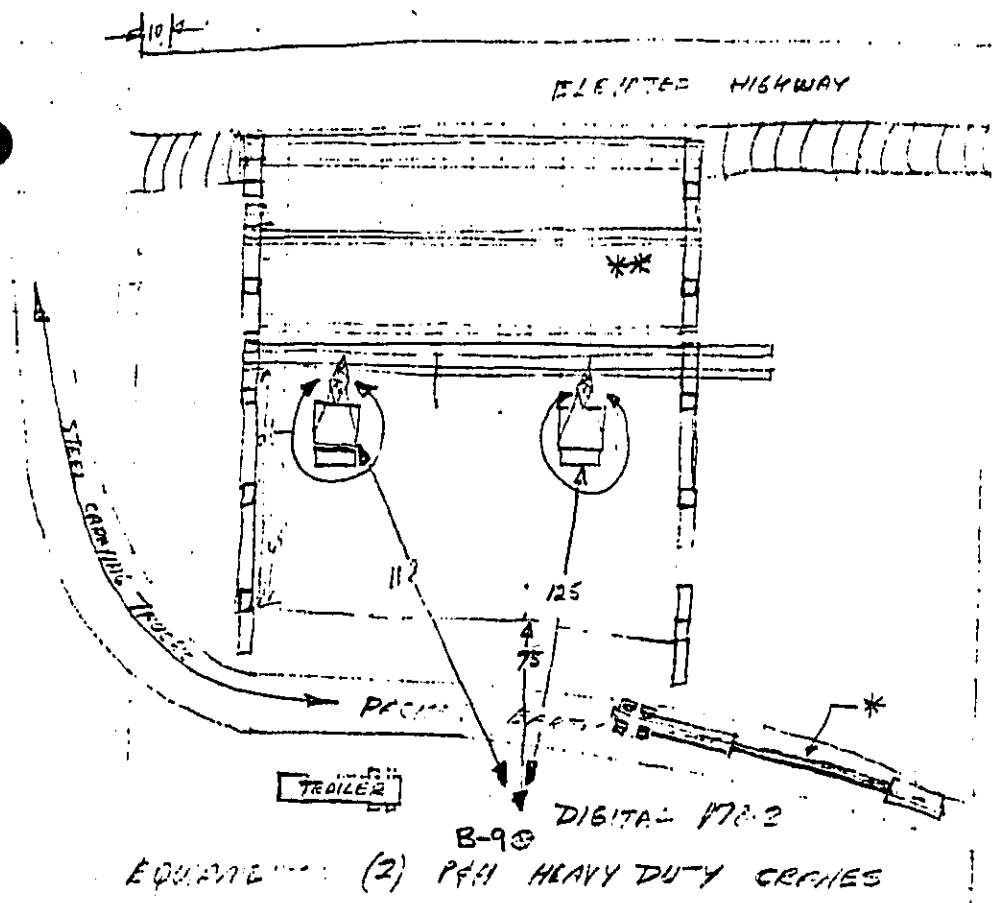

NOTE: AT END OF DAY STEEL PARTS FLD 5-1/2 INCH
IN SECTIONS

TEST REPEATED 11-13 DIGITAL 158-4

- * STEEL GIRDER ON TRAILER AT START OF TEST
- ** AT START THERE WERE 5 1/2 GIRDERS ON SECOND SPAN

Measurement Site Data

Highway: I-95/395

Date: Nov. 1979

Site Location: Bridge Site IV - Finishing work on elevated section of I-395

Type of Measurements:

Community

Activity

Propagation

Site Boundary

Single Equipment

Movies

Soil/Terrain Conditions: Measurements taken on elevated section; concrete roadbed

Machinery Description:

Homelite 2000 Watt Generator
Hand-held electric grinder
Medium duty truck
Man using hammer and chisel

Miscellaneous Information:

DATA LOG SUMMARY

HIGHWAY: I-95/395

DATE: Nov. 1979

SITE LOCATION: Bridge Site IV

Sample	Location	Date	Time	Dur.	Site Diag.	Comments	Reduced
47-45	B-10	11-12	1005	:06	11-12A	Finishing work on bridge	✓

6

DIAGRAM 11-12A OVERPASS FINISHING

ANALOG 45

A 10 K

↑
NORTH

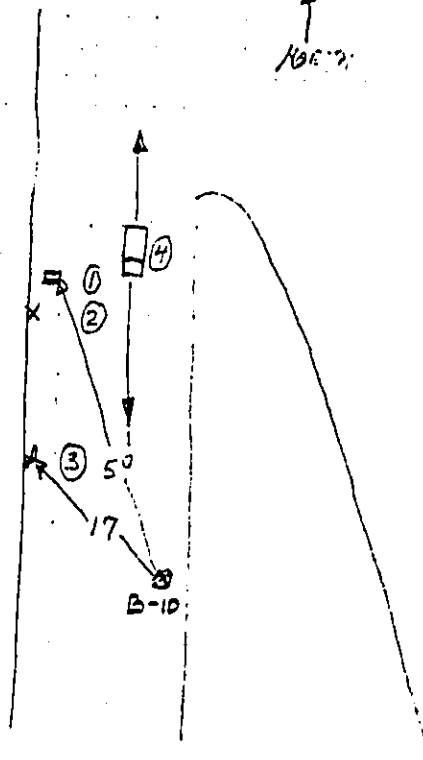

- ① SMALL SECTION HOME SITE 2003/11/17
- ② MAIN MAINS HANDED 8' STEEL
- ③ HAND ELECTRIC GRINDER
- ④ MAIN STAIR

METAL JOINTS
LAW 84 Leg 73 FOR GRIND

Measurement Site Data

Highway: I-95/395

Date: Nov. 1979

Site Location: Concrete Batch Plant

Type of Measurements:

- | | | |
|---|--|--------------------------------------|
| <input type="checkbox"/> Community | <input type="checkbox"/> Activity | <input type="checkbox"/> Propagation |
| <input checked="" type="checkbox"/> Site Boundary | <input checked="" type="checkbox"/> Single Equipment | <input type="checkbox"/> Movies |

Soil/Terrain Conditions: Flat terrain

Machinery Description:
Mack Cement Trucks w/ Straight Stocks
Diesel Generator
IH Hough 80 Pay Loader

Miscellaneous Information:

07

DIAGRAM 11-7C CONCRETE BATCH MIXING PLANT

Mark Cement Truck w/
Straight Stack

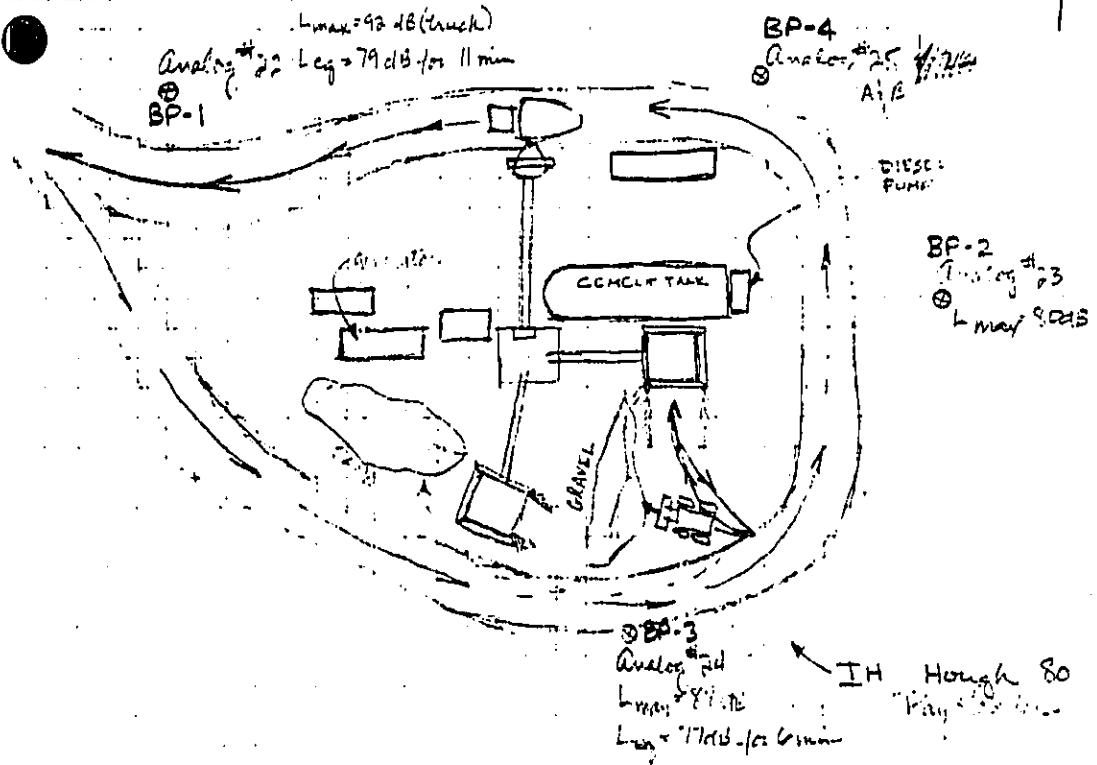

Measurement Site Data

Highway: I-95/395

Date: Nov. 1979

Site Location: Single Equipment Measurement - Front
End Loader

Type of Measurements:

Community

Activity

Propagation

Site Boundary

Single Equipment

Movies

Soil/Terrain Conditions: Propagation measurements performed
on concrete roadbed

Machinery Description:

Clark-Michigan 175B Front End Loader
• Engine fully enclosed.

Miscellaneous Information:

NOTE: Sample 21A: Left-side of loader facing mic's
21B: Rear (fan intake) facing mic's

DIAGRAM 11-7A STATIONARY RUN UP TESTING
 CLARK-MICHIGAN FRONT END LOADER 175B

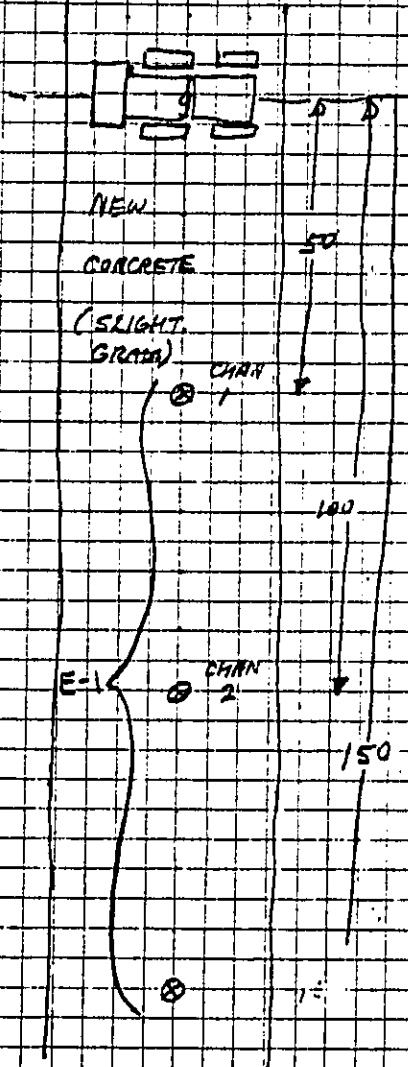
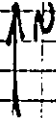

ANALOG #2

	AVC	MEASUREMENT
	P	LOCATION
TEST A	MIC 1.22	L.S.
B	MIC 1.23	L.S.
C	MIC 1.25	REAR
D	MIC 1.27	REAR

PIGRAM 11-7B

OPERATIONAL TEST
FRONT END LOADER

ANALOG 2/F

MICHIGAN 175 B (SAME PIECE OF EQUIPMENT
AS USED FOR STAT. TEST)

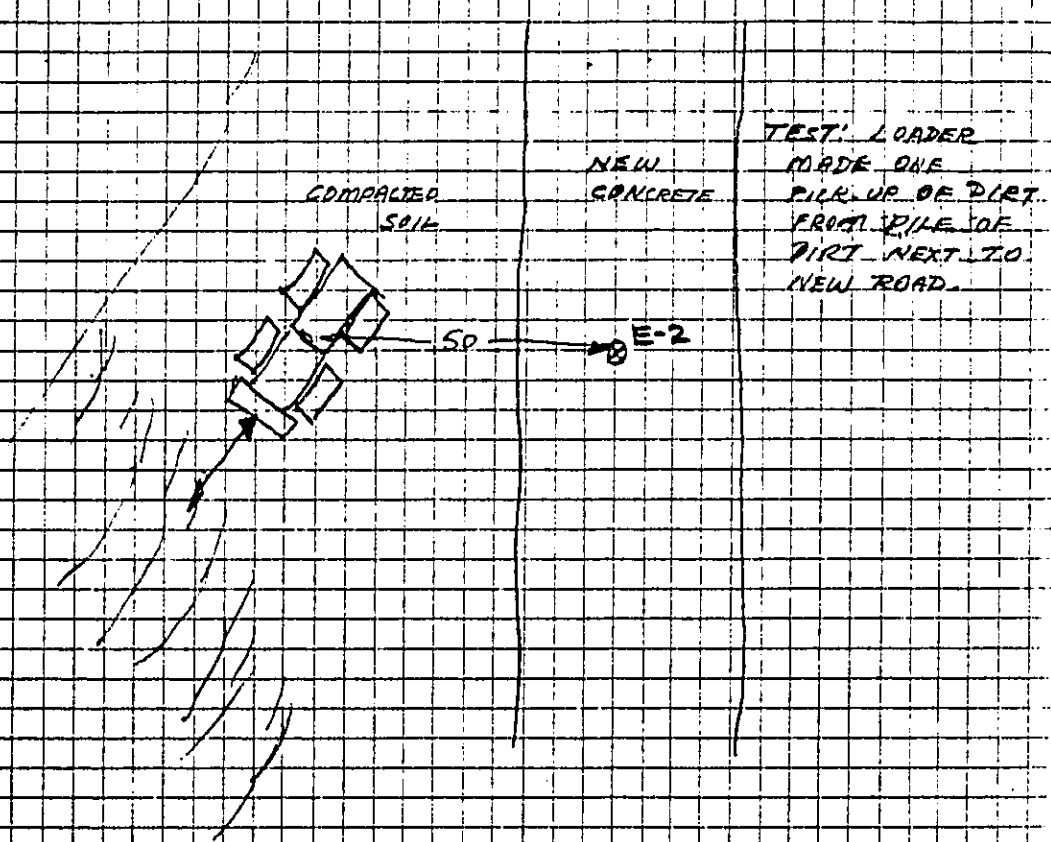

TEST: LOADER
MADE ONE
PICK-UP OF DIRT
FROM PILE OF
DIRT NEXT TO
NEW ROAD.

DIAGRAM 11-5C

ONAN DIESEL GENERATOR

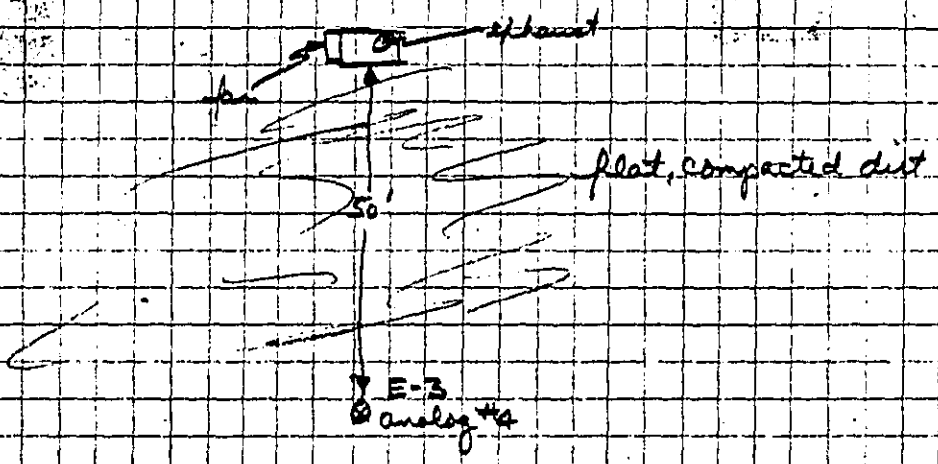

102

Photo Log - 35 mm

Frame #	Location	Date	Time	View or Subject
1	N/G	-	-	-
2	Fill Area I	11-6	0800	F-1 LOOKING SOUTH AT FILL AREA
3	↓	↓	↓	NEAR F-5, LOOKING SOUTH
4	↓	↓	↓	JAEGER AIR COMPRESSOR USED IN EQUIP SUBSTITUTION TEST
5	↓	↓	↓	@ F-2, LOOKING EAST
6	↓	↓	↓	@ F-2, LOOKING NORTHEAST
7	Earthwork Site III	11-6	1030	@ EW-9 LOOKING NORTH AT BACKHOE LOADING TRUCK
8	↓	↓	↓	@ EW-9 LOOKING NORTH AT BACKHOE SCOOPING DIRT
9	↓	↓	↓	-
10	↓	↓	↓	@ EW-10 LOOKING WEST AT KOMATSU LOADER
11	Earthwork Site			
12	Paving Site I	11-6	1340	@ P-1 LOOKING WEST AT PAVER
13	Earthwork Site VI	11-6	1440	@ EW-16 LOOKING SOUTHWEST AT CONVEYOR
14	↓	11-6	1440	@ EW-16 LOOKING AT CONCRETE TRUCK
15	Earthwork Site VIII	11-6	1500	@ EW-18 LOOKING WEST AT BACKHOE
16	↓	11-6	1500	@ EW-19 LOOKING EAST
17	Bridge Site 1	11-6	1615	@ B-4; PILE DRIVER & CRANE
18	Single Equipment	11-7	0800	@ E-1 LOOKING NORTH AT LOADER
19	↓	11-7	0800	FRONT END LOADER; REAR VIEW
20	↓	11-7	0800	" " " ; FRONT VIEW
21	↓	11-7	0800	@ E-2; LOADER DURING OP. TEST

LL #1

60

Photo Log - 35 mm

Frame #	Location	Date	Time	View or Subject
22	Single Equipment	11-7	0800	LOOKING SOUTH @ E-1 MIC'S
23	Batch Plant Site	11-7	1000	@ BP-1 LOOKING S.E. AT GENERATOR
24	↓	11-7	1000	@ BP-2 LOOKING WEST AT CEMENT PUMP
25	↓	11-7	1000	@ BP-3 LOOKING NORTH
26	↓	11-7	1000	@ BP-4 LOOKING AT MIXER
27	Fill Area I	11-7	1430	@ F-5 LOOKING SOUTH
28	↓	11-7	1500	@ F-6 LOOKING EAST AT PASSING TRUCK
29	Bridge Site I	11-7	0900	@ B-3 LOOKING NORTH AT TRACTOR-MOUNTED BREAKER
30	↓	11-7	0900	SAME AS # 29
31	Fill Area II	11-7	1500	@ F-9; SAMPLE NO GOOD
32	Earthwork Site VII	11-7	1555	@ EW-17 LOOKING AT BACKHOE
33	Bridge Site I	11-8	0900	ABATEMENT DEMONSTRATION; MIC. LOCATION FOR EQUIPMENT SUBST. MEASUREMENT
34	↓	11-8	0900	COMPARISON OF STANDARD AND QUIETED JACKHAMMERS
35	↓	11-8	0900	ABATEMENT DEMONSTRATION; LOCATION OF MK. W.C.T. JACKHAMMER
36	Bridge Site II	11-8	0955	@ B-6 LOOKING NORTHWEST AT CEMENT TRUCK AND BUCKET
37	↓	11-8	0955	PIER FORMWORK; CRANE WITH BUCKET IN RAISED POSITION; B-8 IN LEFT CORNER
1	-	-	-	N/G
2	Earthwork Site I	11-8	1430	@ EW-1 LOOKING SOUTH AT APPROACH RAMP FILL AREA
3	↓	11-8	1430	@ EW-1 LOOKING SOUTH/SOUTHEAST
4	↓	11-8	1430	@ EW-1 LOOKING SOUTHEAST

L#2

#2-9
PANORAMIC
SHOT
FROM
POSITION EW-1

Photo Log - 35 mm

Frame #	Location	Date	Time	View or Subject
5	Earthwork Site I	11-8	1430	@EW-1 LOOKING EAST/SOUTHEAST
6	↓	↓	↓	@EW-1 LOOKING WEST
7	↓	↓	↓	@EW-1 LOOKING EAST/NORTHEAST
8	↓	↓	↓	@EW-1 LOOKING NORTHEAST
9	↓	↓	↓	@EW-1 LOOKING NORTH
10	Earthwork Site I	11-8	1450	@EW-2 LOOKING AT CRANE
11	↓	↓	↓	@EW-3 LOOKING AT BACKHOE
12	↓	↓	↓	@EW-4 LOOKING SOUTH AT SCRAPER PASSBY
13	↓	↓	↓	@EW-4
14	↓	↓	↓	@EW-4
15	↓	↓	↓	@EW-
16	↓	↓	↓	@EW-6 LOOKING S.W. AT CRANE/PILE DRIVER
17	↓	↓	↓	@EW-6 LOOKING NORTH
18	↓	↓	↓	@EW-7 SCRAPER MOVING INTO POSITION IN FRONT OF PILE (LOOKING N.E.)
19	↓	↓	↓	@EW-7 LOOKING EAST; SCRAPER BEING PUSHED BY DOZER
20	Earthwork Site III	11-9	0945	@EW-12 LOOKING NORTH AT BUCYUS-ERIS BACKHOE
1	Bridge Site I	11-9	0930	STANDARD CHICAGO-PNEUMATIC JACKHAMMER
2	↓	↓	↓	@B-1 LOOKING WEST
3	↓	↓	↓	STANDARD JACKHAMMER
4	↓	↓	↓	QUIETED JACKHAMMERS

L#3

Photo Log - 35 mm

Frame #	Location	Date	Time	View or Subject
5	Bridge Site I	11-9	0930	SAME AS #4
6	↓	↓	↓	SAME AS #5
7	Bridge Site III	11-9	1145	@ B-9 LOOKING NORTHWEST AT LEFT CRANE PREPARING TO RAISE GIRDER
8	↓	↓	↓	@ B-9 LOOKING DUE NORTH
9	↓	↓	↓	@ B-9; LEFT-HAND CRANE
10	↓	↓	↓	@ B-9; RIGHT-HAND CRANE
11	Bridge Site IV	11-12	1005	@ B-10; LOOKING NORTHWEST
12	Earthwork Site IX	11-12	1045	@ EW-20 LOOKING EAST AT TRACK DOZER SITTING IDLE
13	Earthwork Site III	11-12	N/A	CLOSE-UP OF WATER TRUCK OPERATING ON STREET ALONG EAST SIDE OF SITE
14	Paving Site II	11-12	N/A	@ P-3 LOOKING WEST AT DUMP TRUCK FEEDING ASPHALT TO PAVER
15	↓	↓	↓	@ P-3 AFTER PAVER HAD PASSED
16	↓	↓	↓	@ P-3; DYNAPAC VIBRATORY ROLLER
17	-	11-2		CONCRETE PAVING TRAIN (NOT MEASURED DUE TO RAIN)
18	-			SAME AS #17
19	-			SAME AS #17
20	-			SAME AS #17
21	-			SAME AS #17

ROLL # 1

NOT GOOD

1

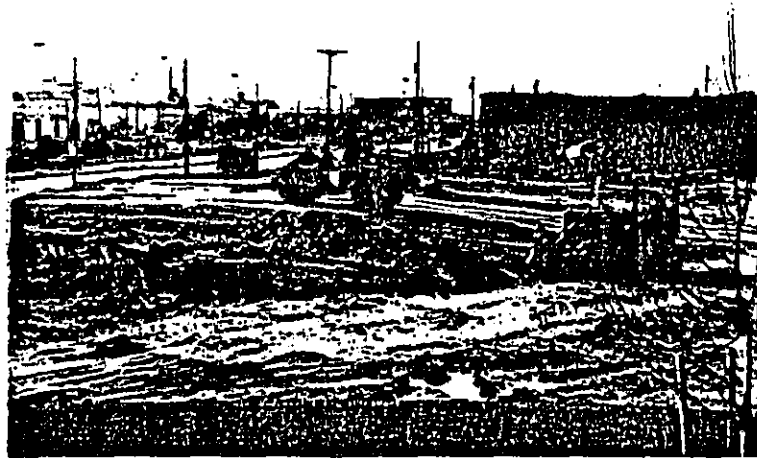

2

107

BLACK COPY



#3

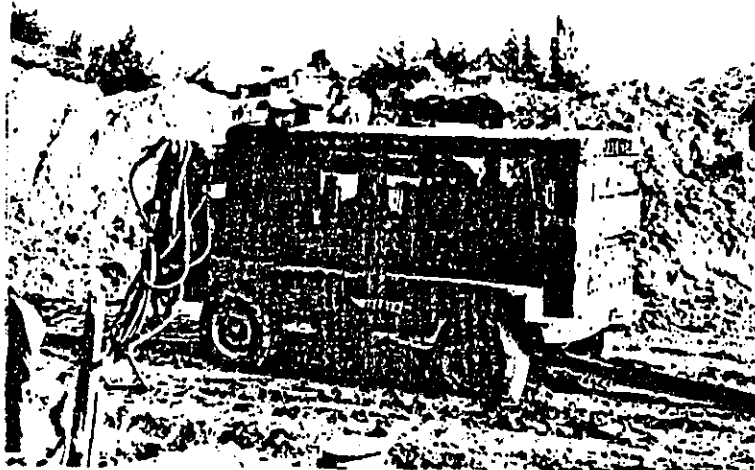

#4



#5

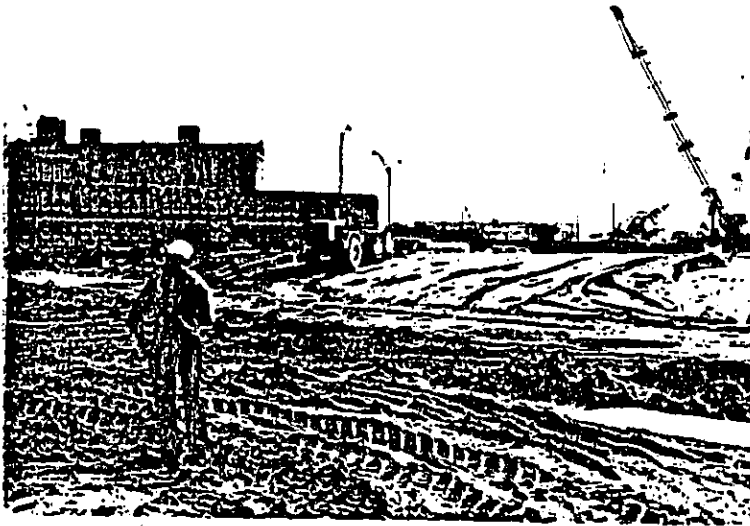

#6



#7

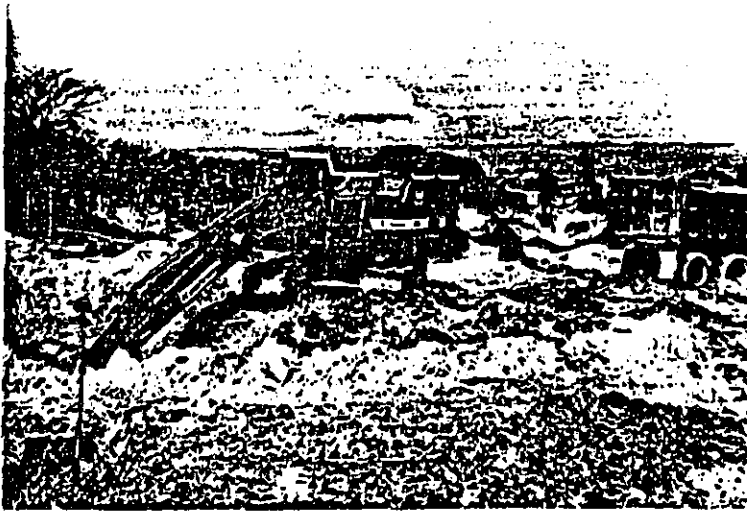

#8

110



#9



#10

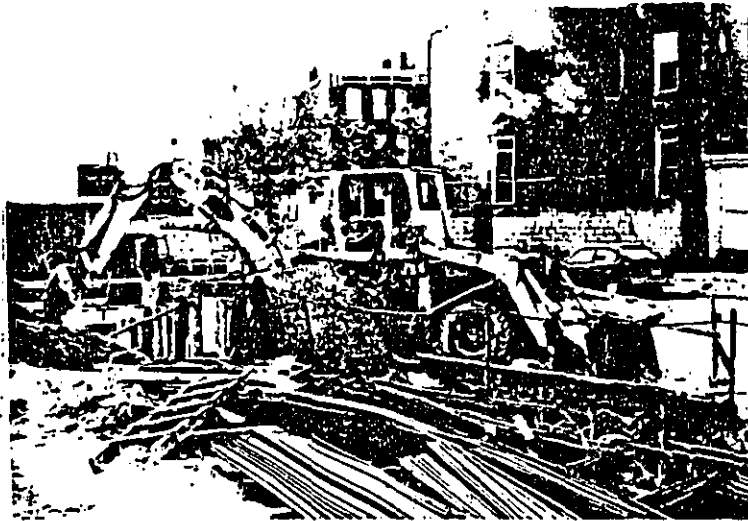

#11

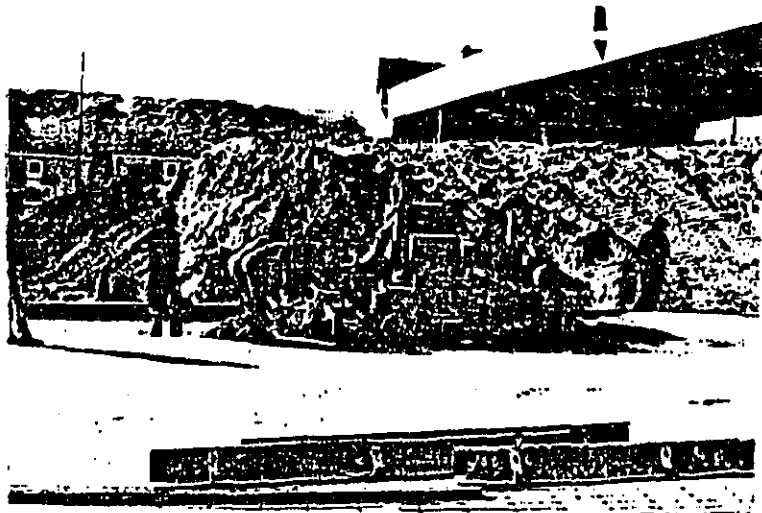

#12

1/2

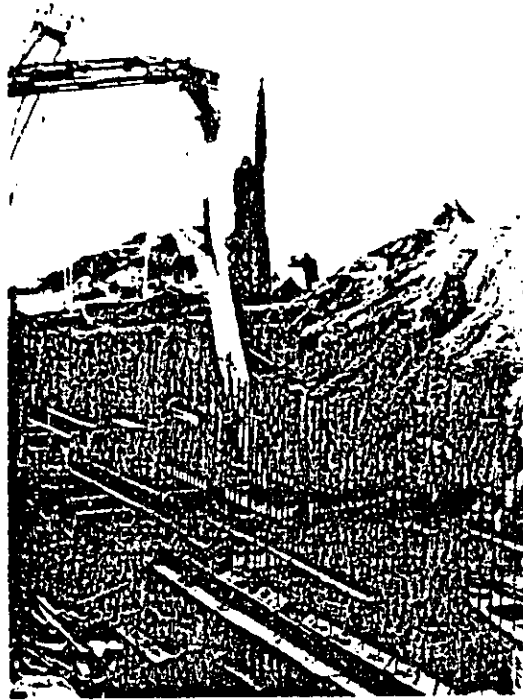

#13

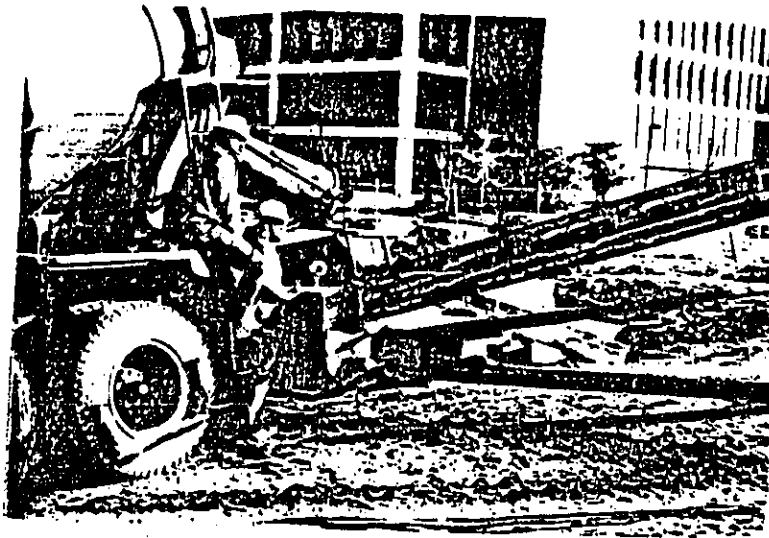

#14

BACK COPY

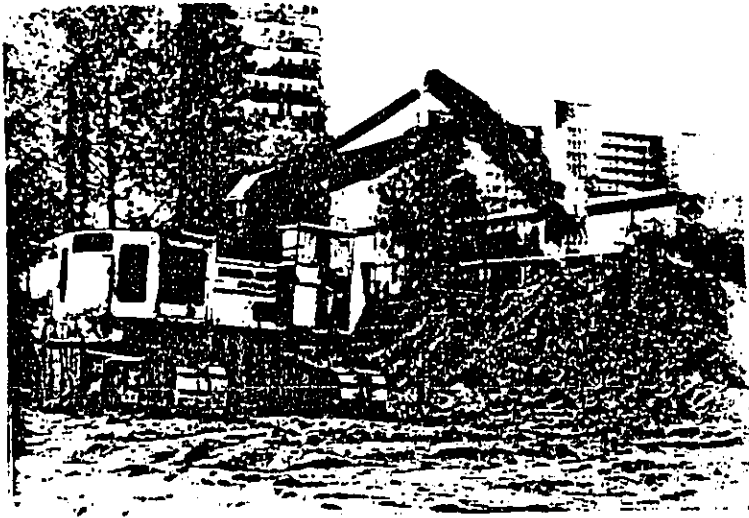

#15



#16

114

BLACK COPY

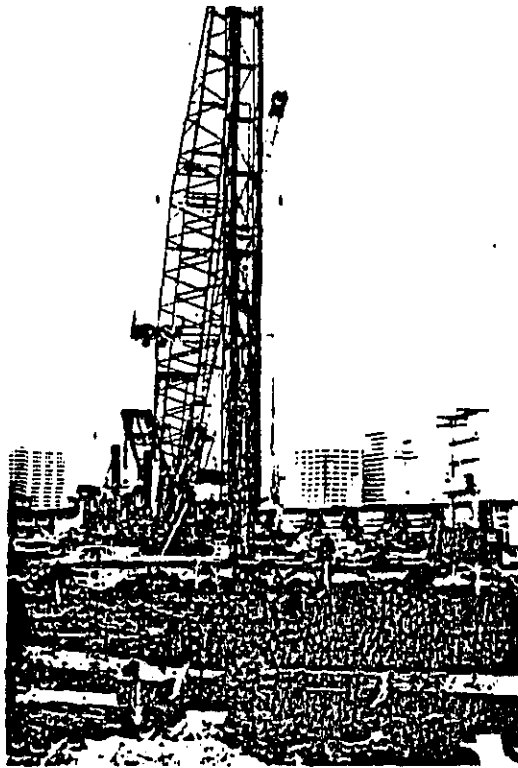

#17

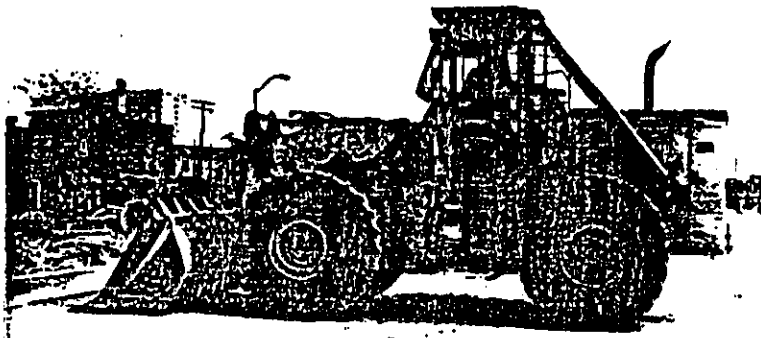

#18

115

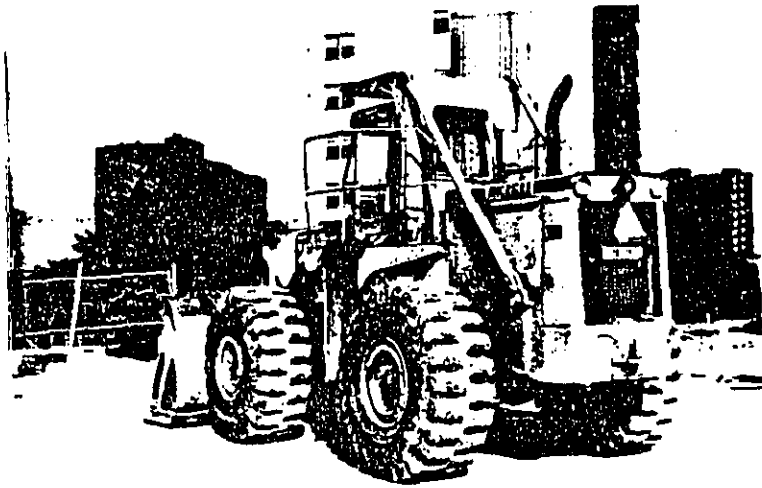

#19

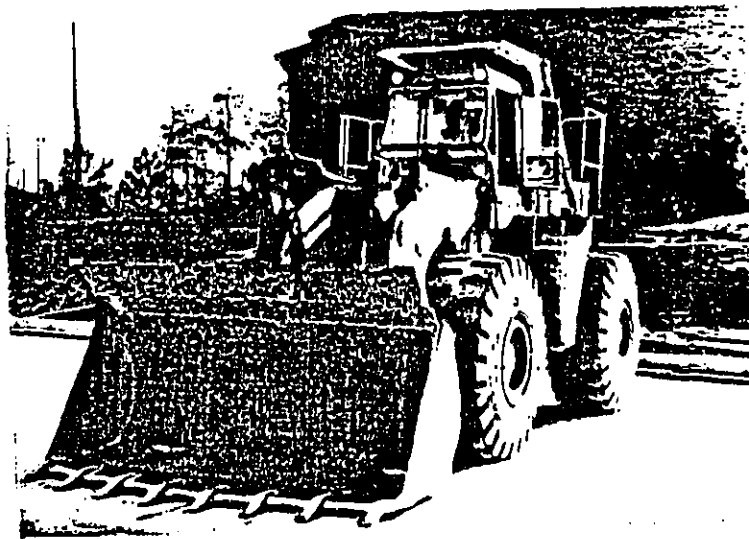

#20

BLACK COPY

116

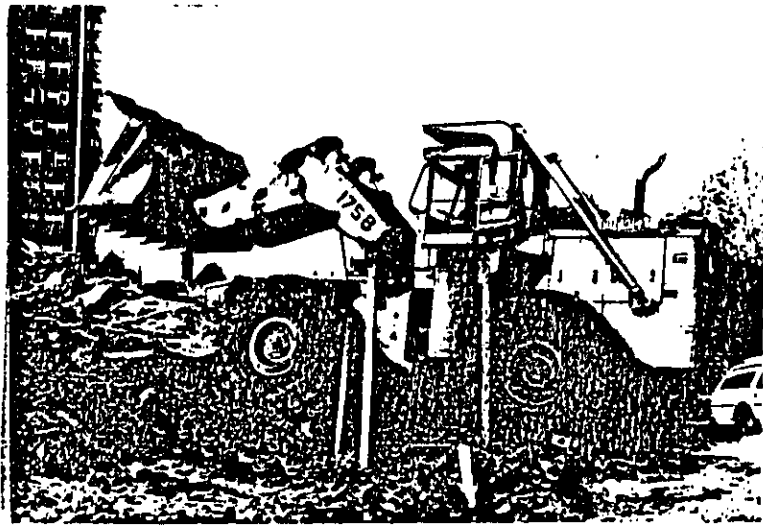

#21

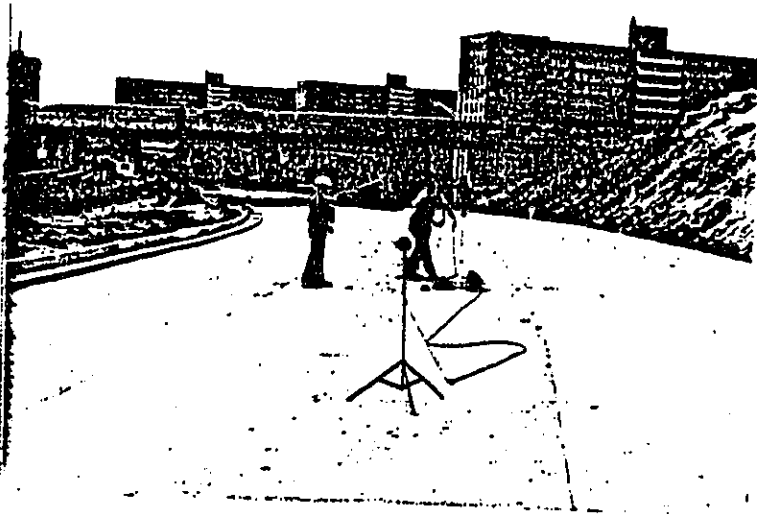

#22

117

BLACK COPY



#23

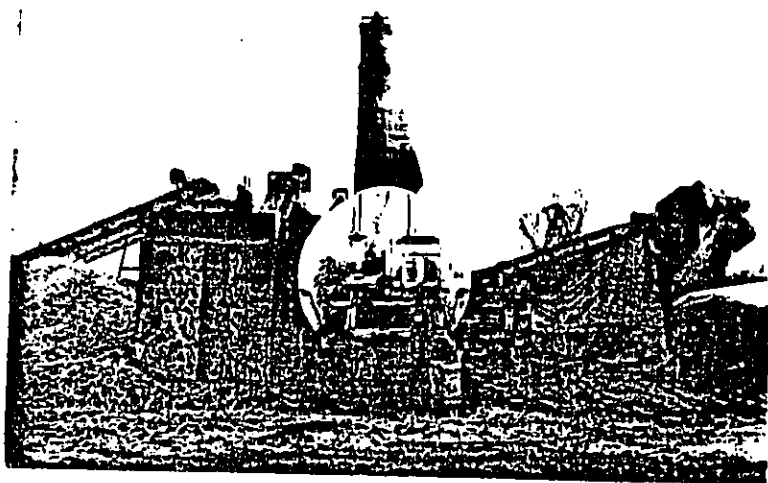

#24

118

BLACK COPY

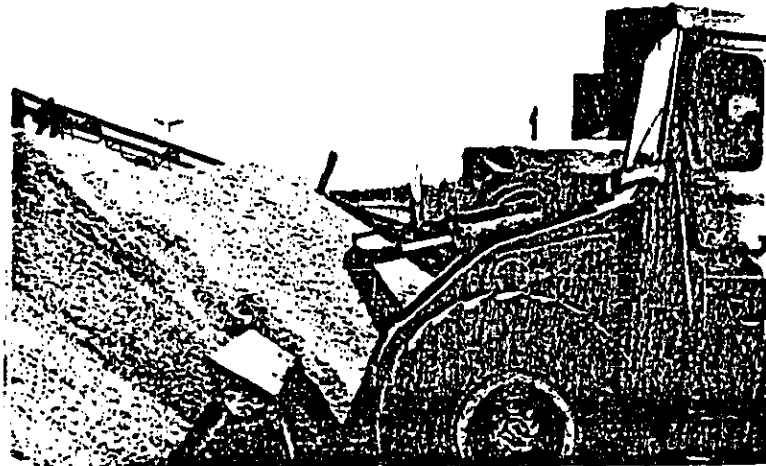

#25

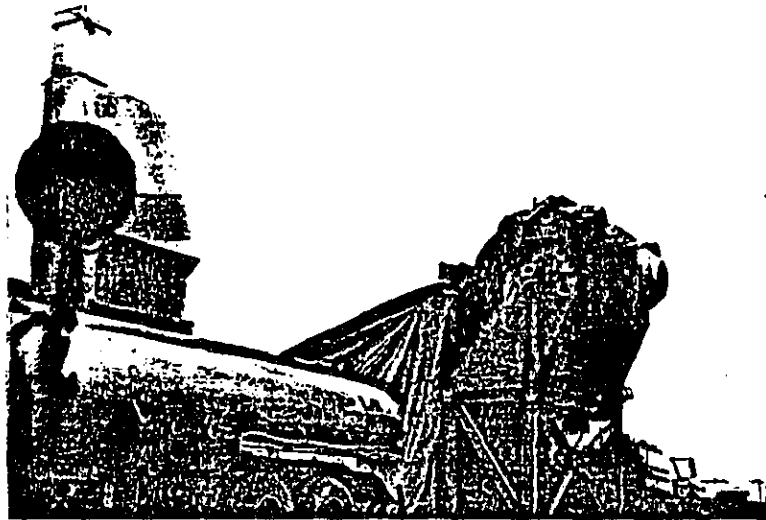

#26

BLACK COPY

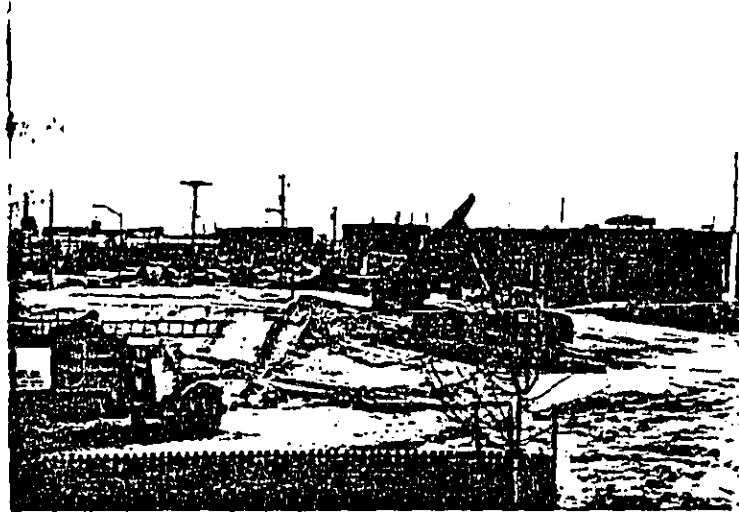

#27

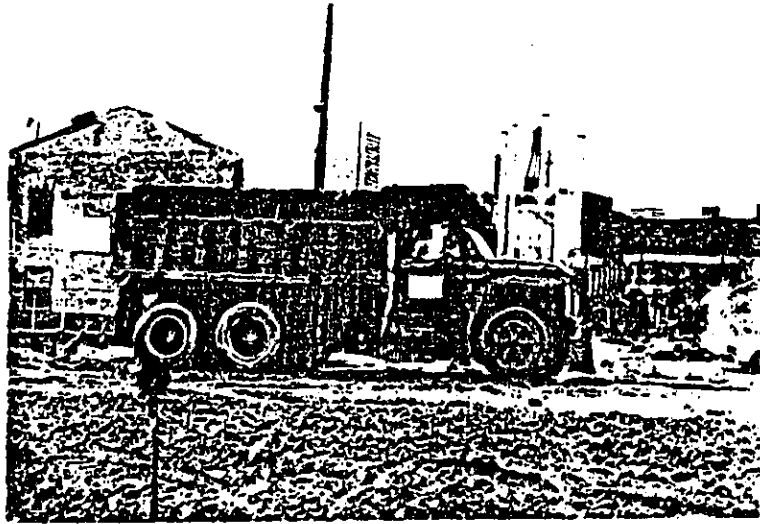

#28

126

BLACK COPY

BLACK COPY

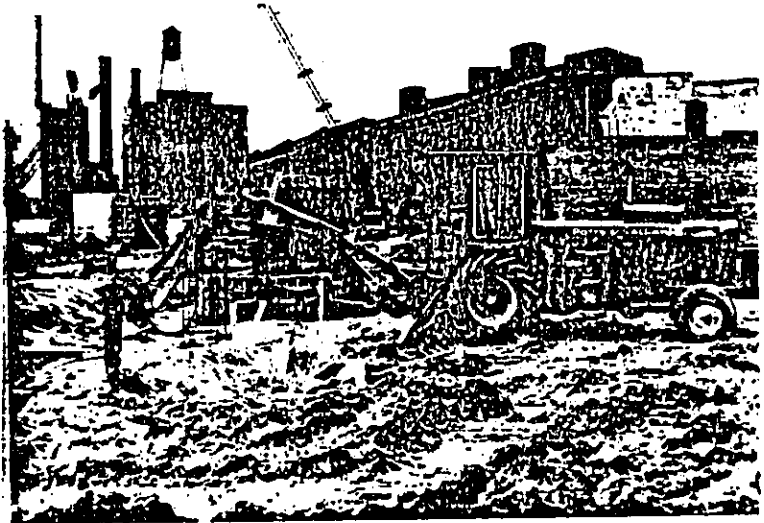

#29



#30

121

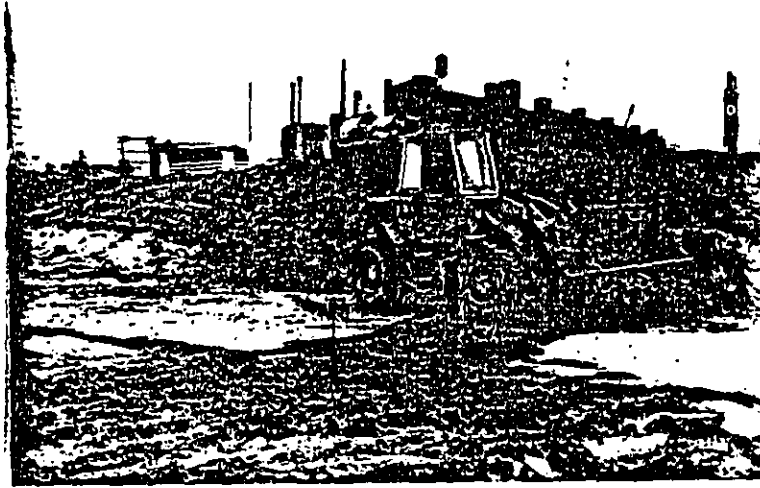

#31

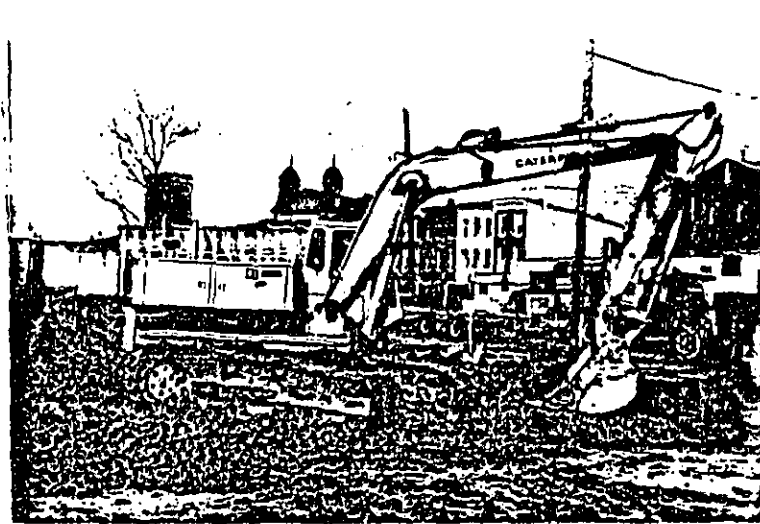

#32

BLACK COPY

122

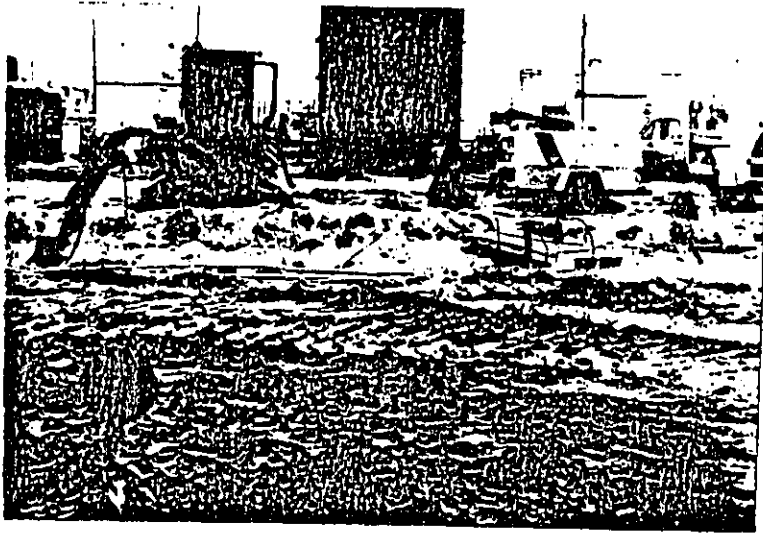

#33



#34

BLACK COPY

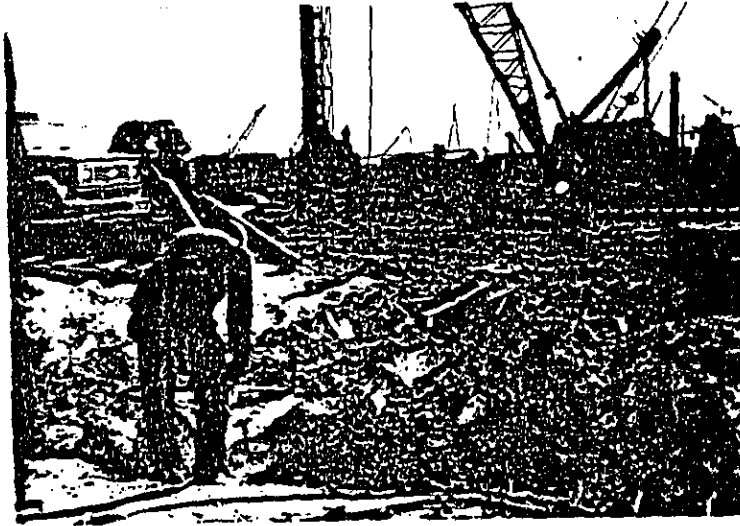

#35

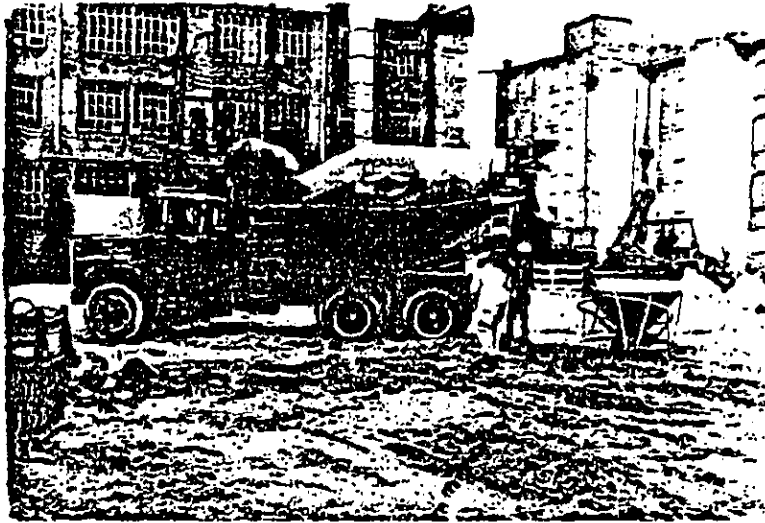

#36

BLACK COPY

134

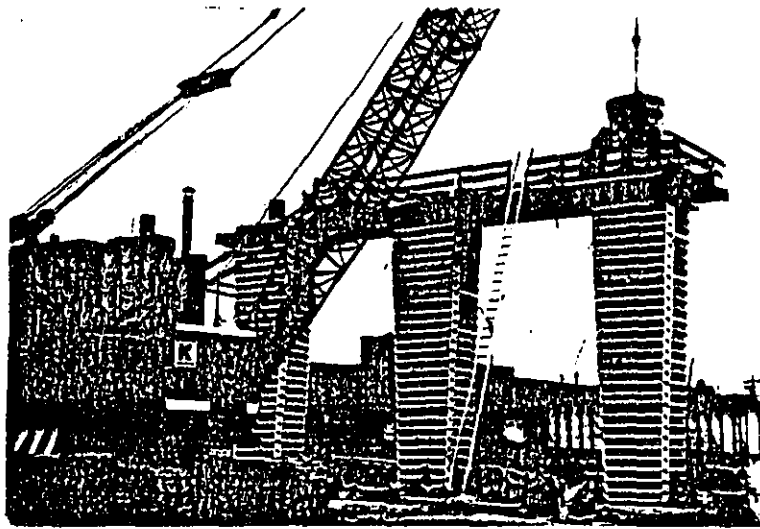

#37

RI ACK COPY

125

ROLL #2

#1 HOT GOOD



#2

126

RI ACK COPY

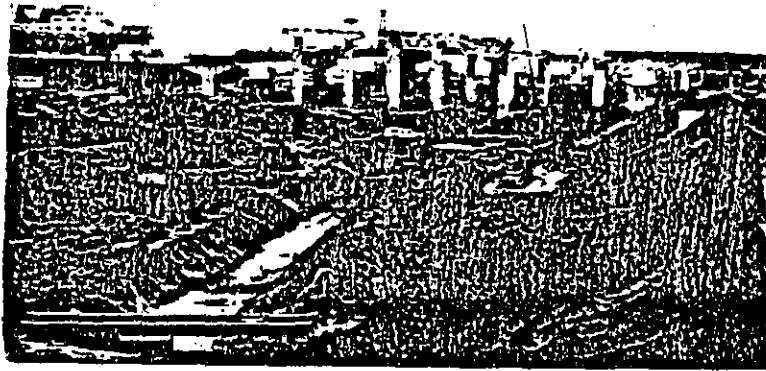

#3

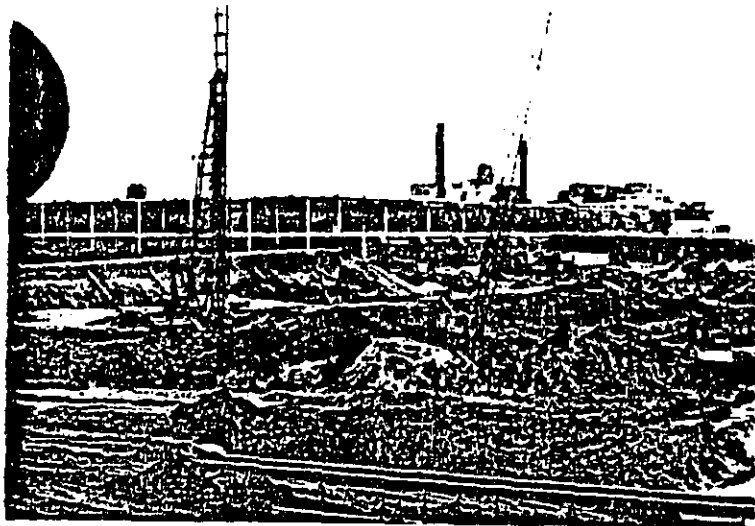

#4

BLACK COPY

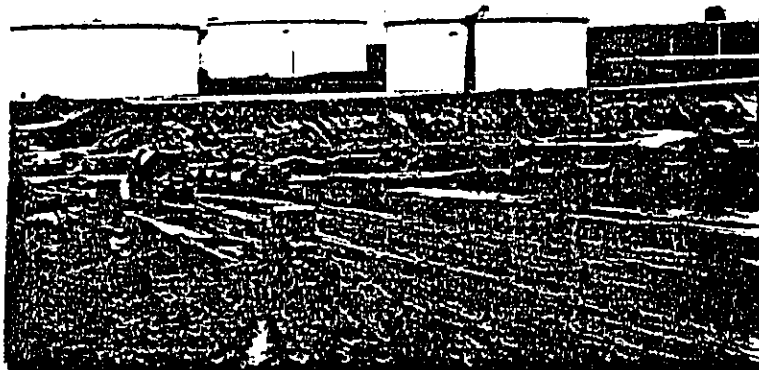

#5

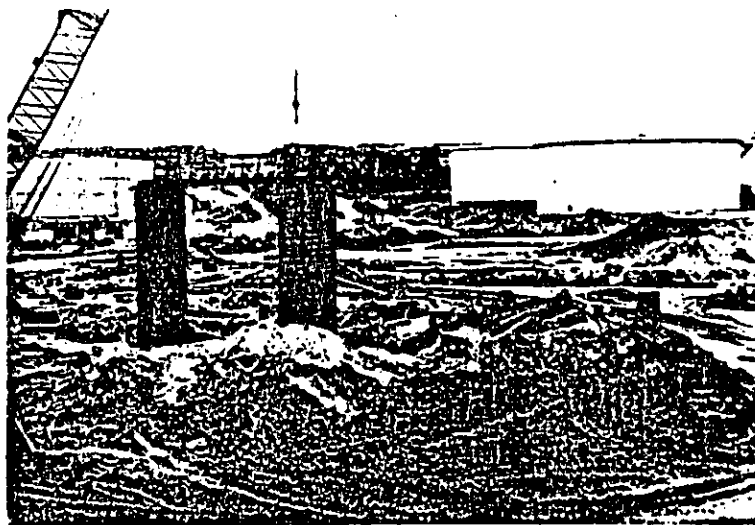

#6

BLACK COPY

125

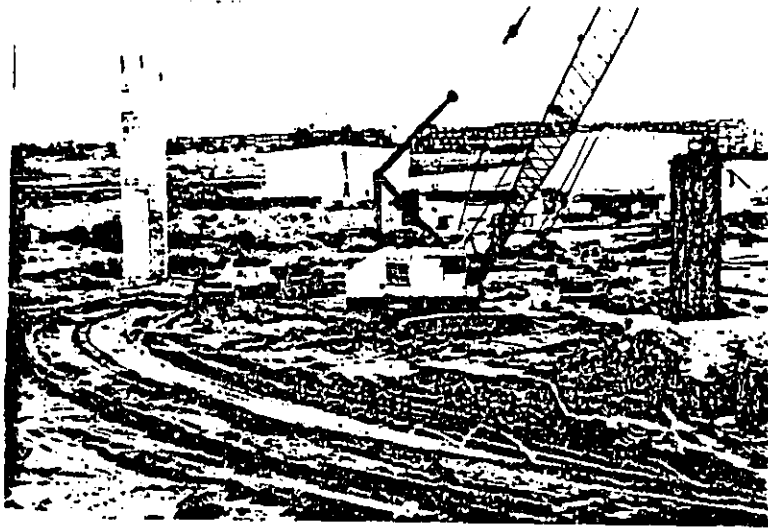

#7

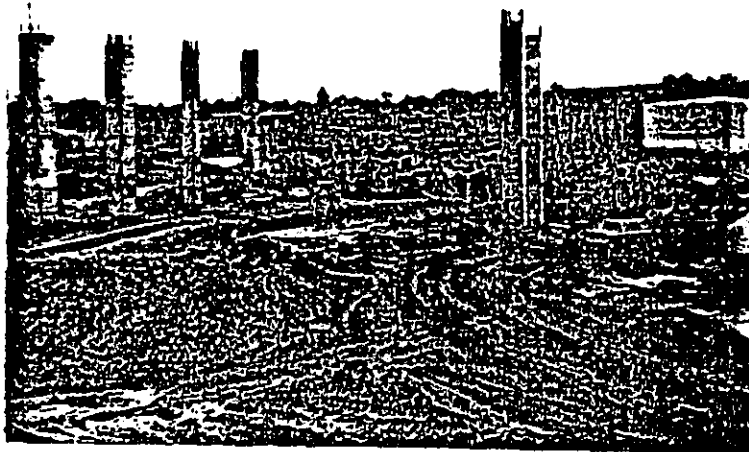

#8

DIAPHRAGM



#9

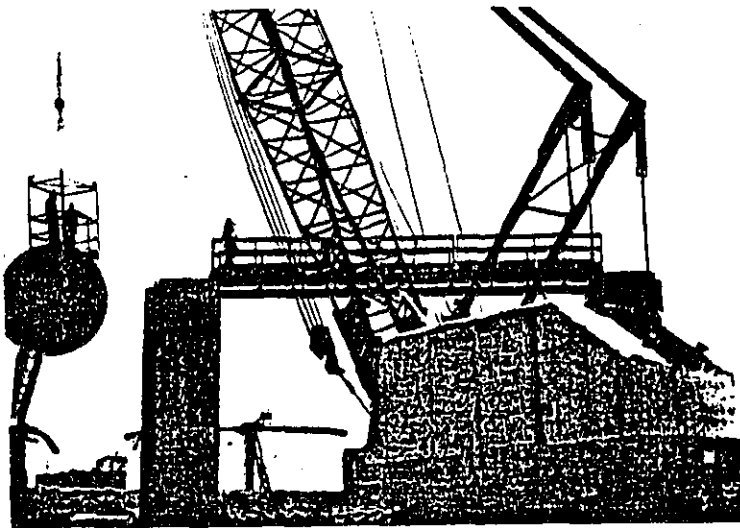

#10

130

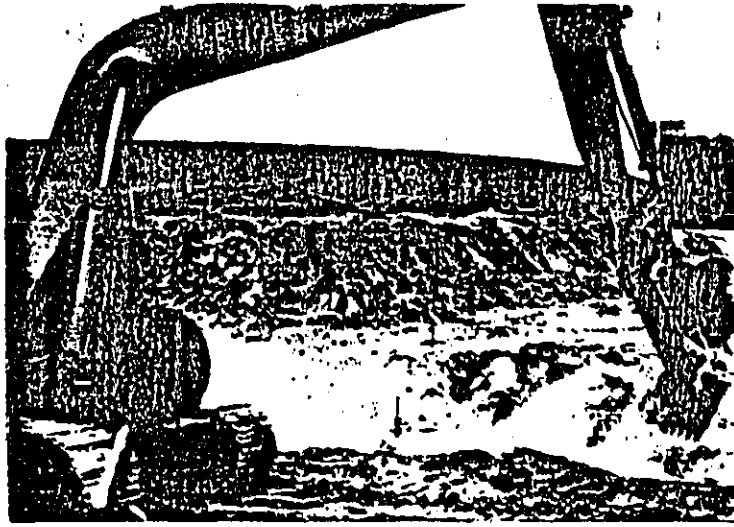

#11

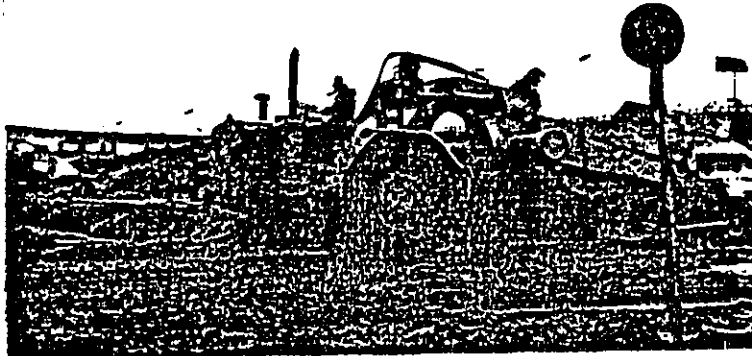

#12

(3)

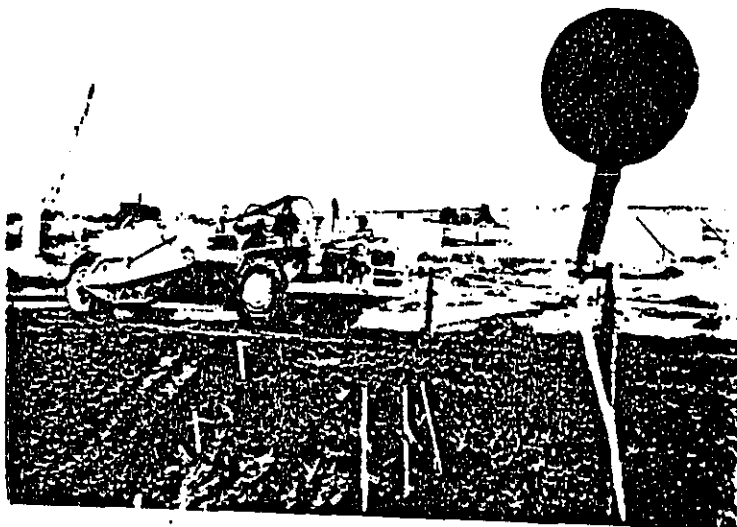

#13

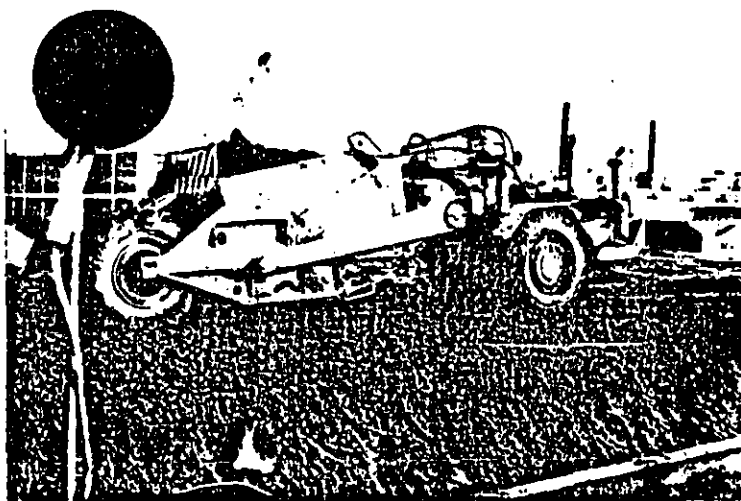

#14

132

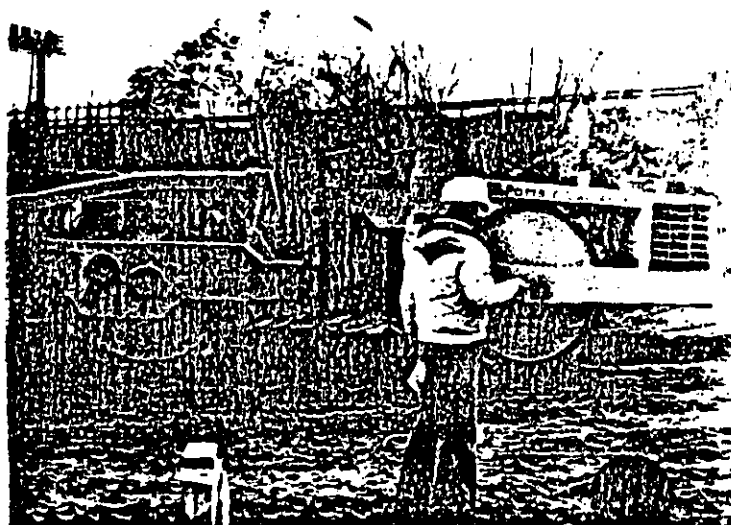

#15

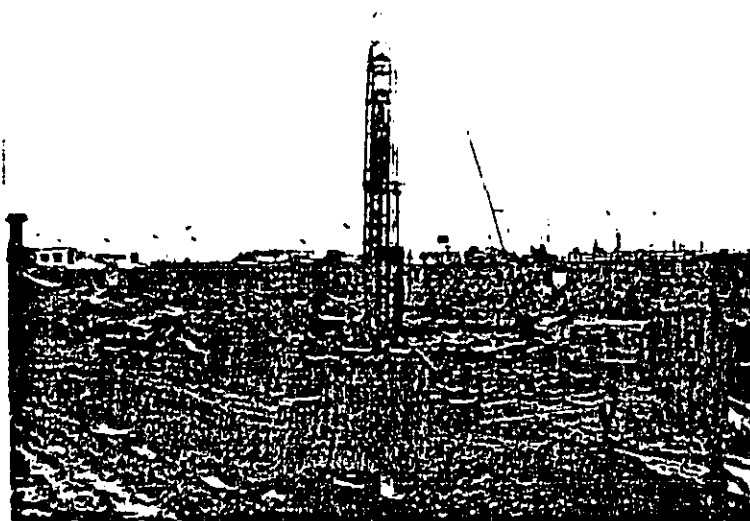

#16

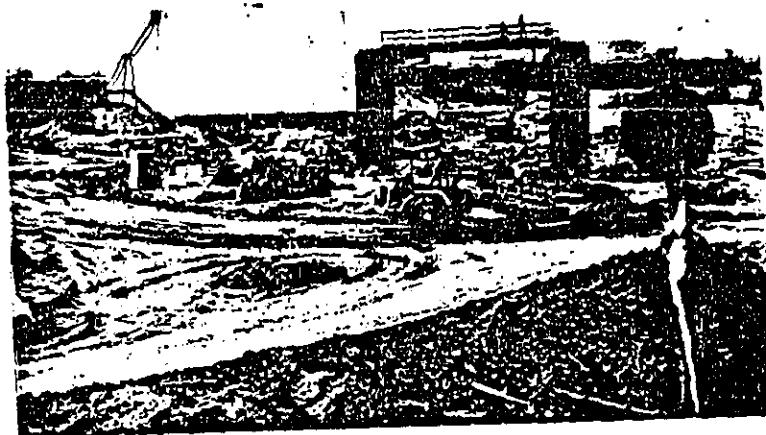

#17

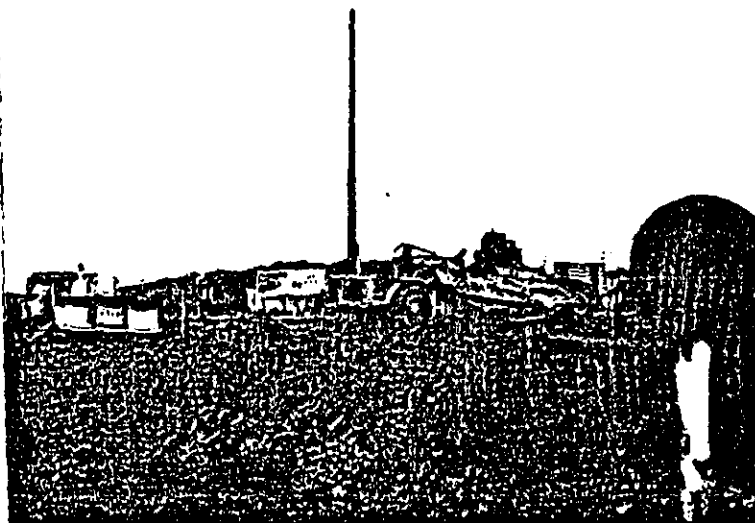

#18

134

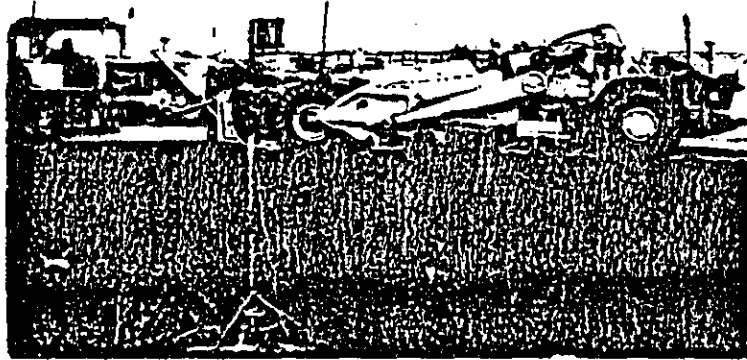

#19



#20

131-

Row #3



#1



#2

136



#3



#4

137



#5



#6

13i

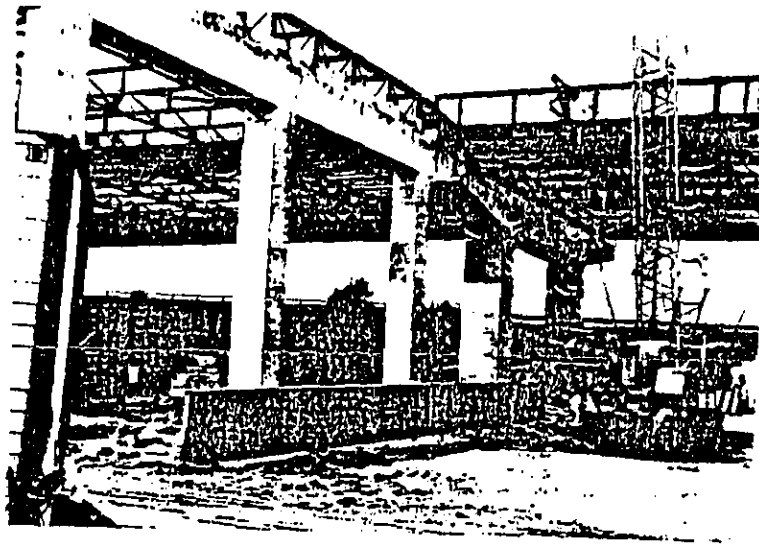

#7



#8

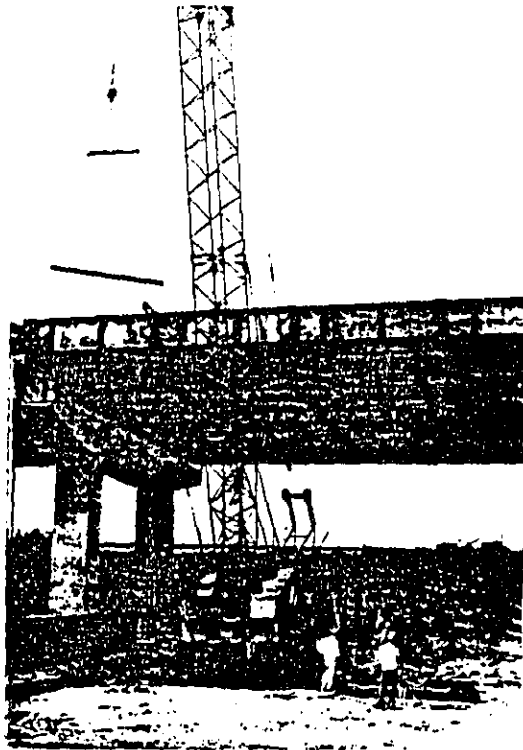

#9

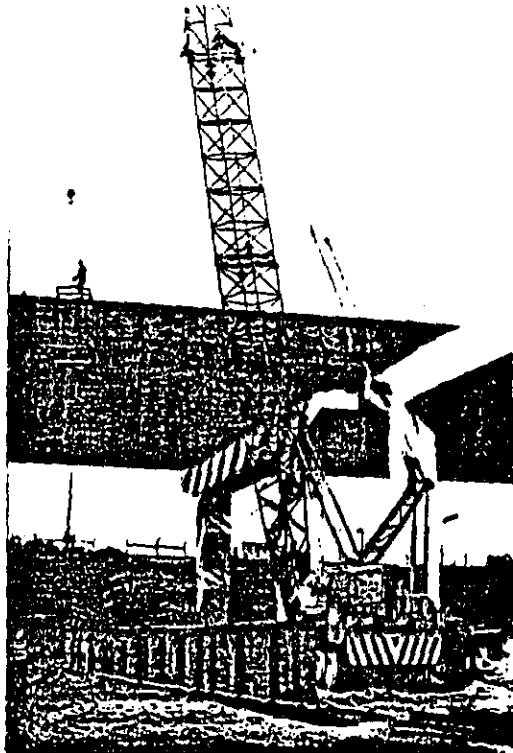

#10

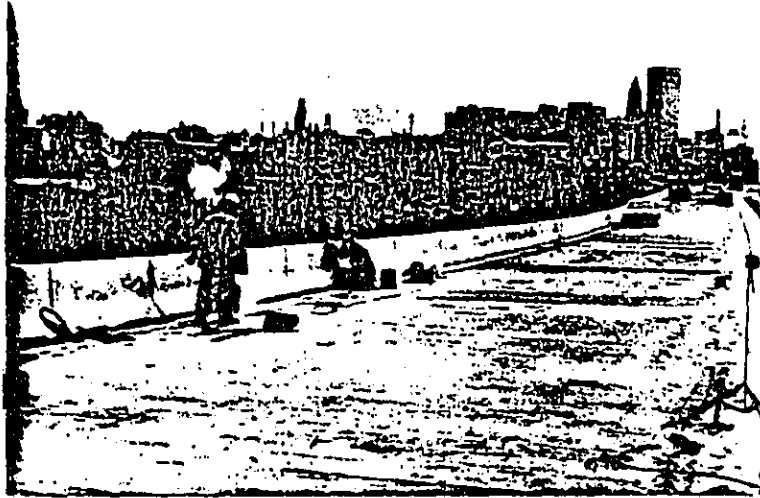

#11

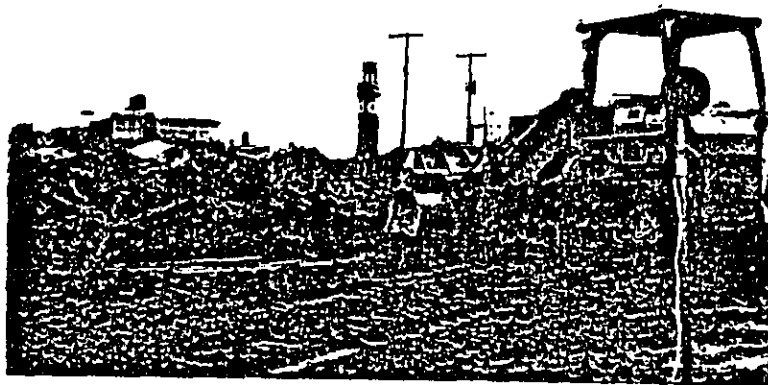

#12

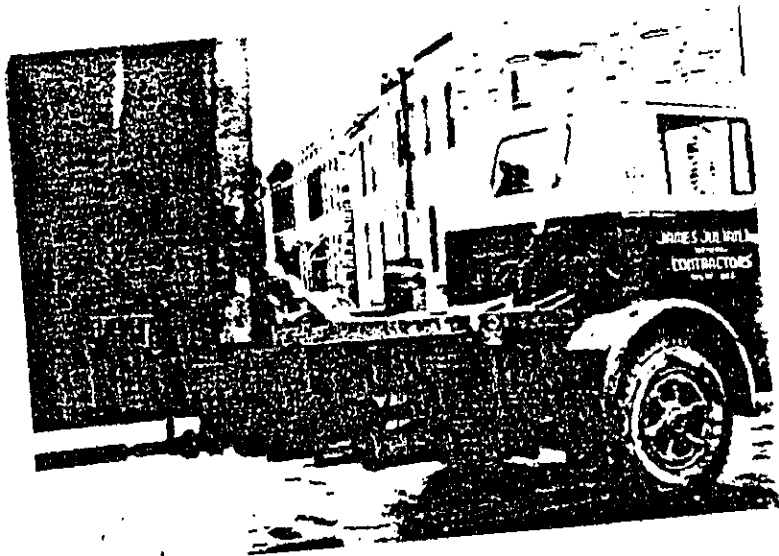

#13



#14

142

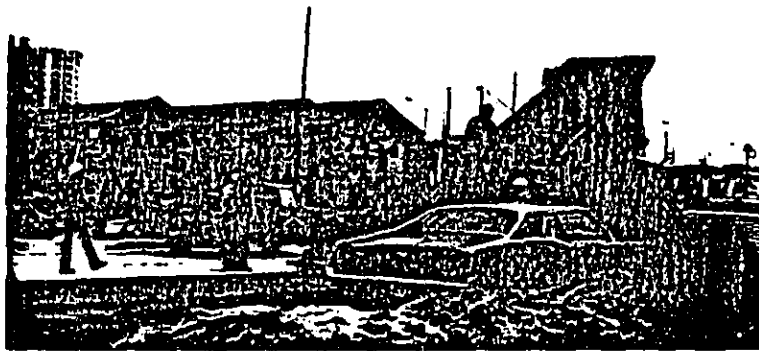

#15

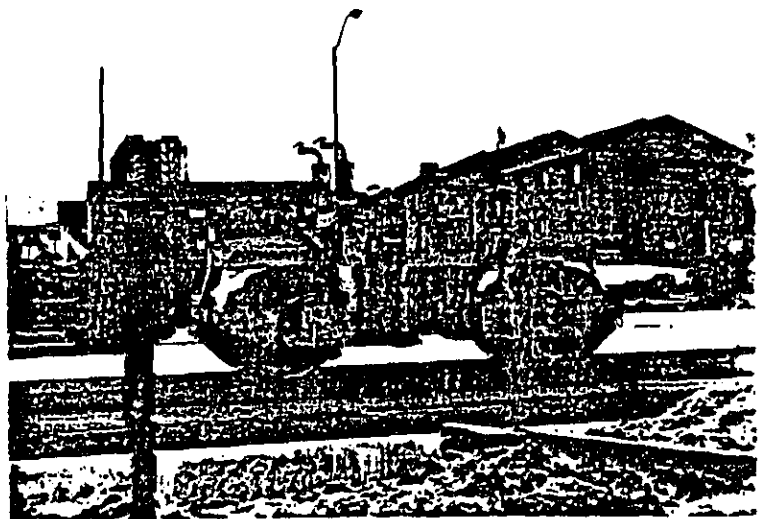

#16

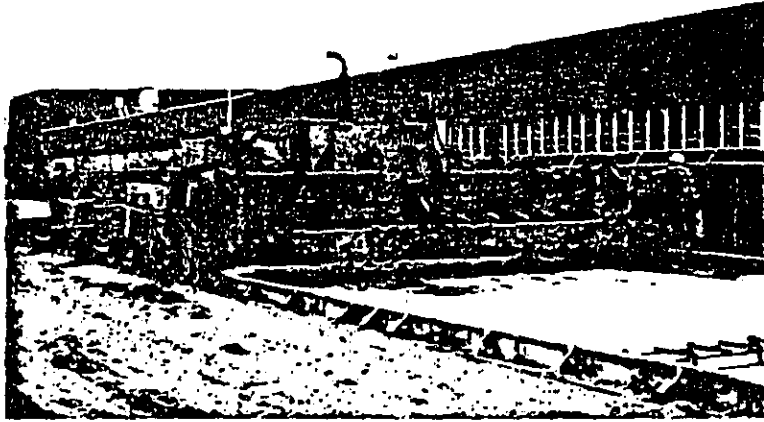

#17

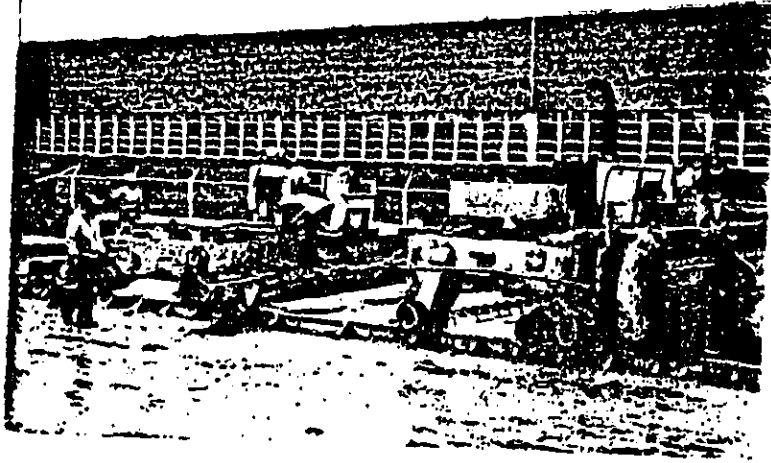

#18

1968



#19



#20

5

17

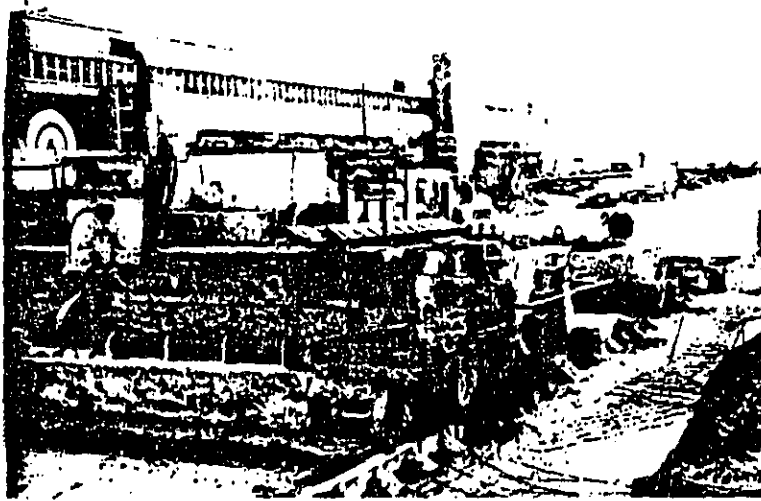

21