

Report No. 2391

D-96-01
II-A-854

THE EFFECT OF TUNNEL ACOUSTIC TREATMENT ON
THE NOISE INSIDE SUBWAY CARS

H.H. Heller
E.K. Bender

7 November 1973

Submitted to:

New York City Transit Authority
370 Jay Street
Brooklyn, New York 11201
Attention: Mr. Anthony Paolillo

THE EFFECT OF TUNNEL ACOUSTIC TREATMENT ON
THE NOISE INSIDE SUBWAY CARS

H.H. Heller
E.K. Bender

BBN Report No. 2391

7 November 1973

Submitted to:

New York City Transit Authority
370 Jay Street
Brooklyn, New York 11201
Attention: Mr. Anthony Paolillo

ABSTRACT

This report investigates the possibilities and limitations of reducing the noise levels in the New York City Transit Authority (NYCTA) subway cars by acoustic treatment of the surfaces in subway tunnels. Acoustic measurements were conducted in NYCTA cars for various operating conditions. These were complemented by measurements outside the cars to obtain transmission loss data for various structural components of the cars. The report concludes with specific recommendations and provides estimates of their effect on car-interior levels. The accompanying figure summarizes the changes in the car interior sound pressure level spectrum for various environmental conditions. (This figure is shown in full size as Fig. 22 in this report.)

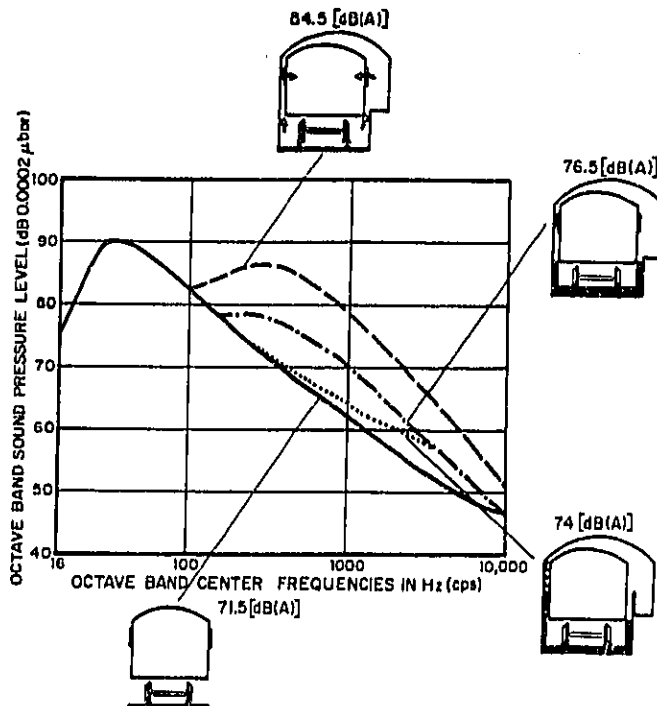

TABLE OF CONTENTS

	page
ABSTRACT	iii
LIST OF FIGURES	vi
1. INTRODUCTION	1
2. PROBLEM DEFINITION	4
3. TEST PROGRAM	7
3.1 Experimental	7
3.2 Data Presentation and Discussion	10
3.3 Nondimensional Spectra	11
3.4 Discussion	12
4. TUNNEL ABSORPTIVE-TREATMENT	20
4.1 Trackbed	20
4.2 Side Walls of Trackbed Recession	24
4.3 Tunnel Side Walls	25
4.4 Tunnel Ceiling	27
4.5 Cat Walk Treatment	28
4.6 Estimate of Combined Effect of Tunnel Treatment ...	30
5. RECOMMENDATIONS	33
REFERENCES	37
APPENDIX A: REPRESENTATIVE ACOUSTICAL DATA OBTAINED ON THE NYCTA SUBWAY SYSTEM	38

LIST OF FIGURES

	page
Fig. 1. Car-Interior Noise Levels at 35 mph in Tunnel ...	1
2. Energy Flow Diagram for Subway Noise	5
3. Preferred Noise Criteria (PNC) Curves	6
4. Measurement Locations	8
5. Measurement Sites Arrangements	9
6. Tunnel/Car Geometry	10
7. Normalized Spectrum in Car, in Tunnel	11
8. Normalized Spectrum at Wall, in Tunnel	12
9. Normalized Spectrum in Tunnel, Between Tracks ...	13
10. Difference in Car Exterior and Car Interior Level (zero-dB Level)	14
11. Difference in Car Exterior (Space 2) and Car In- terior (Space 3) Levels and Transmission Loss (TL) of 1/8 in. thick Glass and Specific Noise Reduction (NR) for Window Area of NYCTA Cars	15
12. Approximate Relationship Between Room Volume and Room Constant for Spaces of Various Average Acoustic Absorption (at Mid-Frequency Region of 500-1000 Hz)	16
13. Approximate Wall or Floor Correction Term "C" for Use in the Equation $NR = TL + "C"$	17
14. Comparison of Car-Interior Spectra for Two Con- ditions	18
15. Comparison of Spectra Between Rails	19
16. Trackbed Lining	20

	page
Fig. 17. Complete Treatment of Trackbed Recess	22
18. Reduction in Sound Pressure Level (SPL) When Absorption Coefficient of Trackbed is Changed from a Low Value α_1 to a High Value α_2 , for the <i>Specific</i> Tunnel Geometry Shown in Fig. 6	23
19. Treatment of Side Wall Ceiling and "Banister Construction"	26
20. Attenuation in a Duct Per Foot of Duct Length, for Thickness t of Absorptive Layer, with $D = 2$ ft and Two Opposing Sides Absorptive-Lined, or $D = 1$ ft with One Side Absorptive-Lined and Opposing Side Acoustically Hard	26
21. Treatment of Catwalk Sidewall	28
22. Reduction in Sound Pressure Level (SPL) when Absorption Coefficient of Catwalk Wall is Changed from a Low Value α_1 to a High Value α_2 , for the <i>Specific</i> Geometry Shown in Fig. 6	29
23. Complete Treatment of Tunnel Surfaces	30
24. Illustration Example of Effect of Tunnel and Trackbed Acoustic Treatment on Car-Interior Noise Spectrum	31
25. Car-Interior Noise Levels for the Following Conditions: Train (1) in Untreated Tunnel, (2) and (3) in Partially Treated Tunnel, and (4) on Embankment	36
A-1. Time History and One-Third Octave Band Spectrum of Noise Measured Between the Rails for a Train Traveling in a Tunnel at 35 mph	39
A-2. Time History and One-Third Octave Band Spectrum Noise Measured on the Catwalk for a Train Traveling in a Tunnel at 35 mph	40
A-3. One-Third Octave Band Spectrum of Noise Measured in the Train Corresponding to Exterior Measure- ments Illustrated in Figs. A-1 and A-2	41

	page
Fig. A-4. Time History and One-Third Octave Band Spectra of Noise Measured Between the Rails for a Train Traveling in a Cut at 35 mph	42
A-5. Time History and One-Third Octave Band Spectra Measured on a Catwalk for a Train Traveling in a Cut at 35 mph	43
A-6. One-Third Octave Band Spectrum of Noise Measured in the Train Corresponding to Exterior Measurements Illustrated in Figs. A-4 and A-5	44
A-7. Time History and One-Third Octave Band Spectrum of Noise Measured Between the Rails for a Train Traveling on an embankment at 35 mph	45
A-8. Time History and One-Third Octave Band Spectrum of Noise Measured on a Platform Next to a Train Traveling on an Embankment at 35 mph	46
A-9. One-Third Octave Band Spectrum of Noise Measured in the Train Corresponding to Exterior Measurements Illustrated in Figs. A-7 and A-8	47

1. INTRODUCTION

Noise levels in the New York City Transit Authority (NYCTA) cars have been found to be extremely high. Recent measurements conducted by Bolt Beranek and Newman Inc. (BBN) have indicated that on typical in-tunnel straight and level sections at speeds of about 35 mph octave band levels reach 80 to 90 dB over a frequency range of 60 to 1200 Hz. The range of one-third octave band spectra of car-interior noise observed for this operating condition is shown in Fig. 1. Applying standard criteria for the subjective acceptance of such a noise signature makes the need for control measures quite obvious. For example, applying an

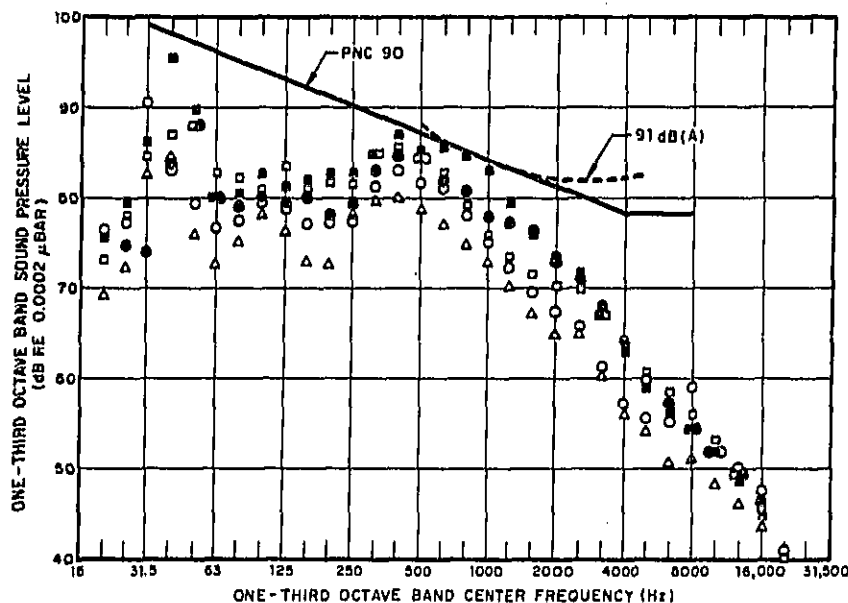

FIG. 1. CAR-INTERIOR NOISE LEVELS AT 35 MPH IN TUNNEL.

(extrapolated) Preferred Noise Criteria (PNC) curve onto the upper bound spectrum shows that the lowest level of concern in terms of Permissible Noise Exposure is exceeded. The Walsh-Healey Public Contracts Act states that a level of 90 dB(A) for an 8 hr period is permissible to avoid a significant degree of permanent hearing damage. Implicit in this regulation is the presupposition that a person exposed to such levels will be in a quiet environment during the remainder of a day in order to recover from the overload on the hearing mechanism. Although a typical passenger is exposed to car-interior noise much less than 8 hrs each day, and is unlikely to suffer hearing damage from transit car noise alone, noise levels are higher than desirable for recovery from occupational exposure.

Applying the criterion of Preferred* Speech Interference Level (PSIL) shows that the upper bound spectrum yields a PSIL of 86 dB [i.e., $1/3 (91 + 89 + 79)$]. In order to allow communication between two people 2 ft apart they would have to shout, or, if only 6 in. apart would still have to talk with a raised voice.

Obviously, changes in train speed will influence the noise levels and the above criteria would change for better or worse depending on the operational conditions.

In order to decrease the car-interior noise levels one needs to identify the noise sources, and where possible control the levels *at the source*. As a subsequent measure one would control both the structureborne and airborne *propagation paths* to minimize transmitted sound. Since the dominant sources of subway

*The term "preferred" relates to the octave band center frequencies now used to characterize bands. These are on 500, 1000, 2000 Hz, rather than the old 600-1200, 1200-2400, 2600-4800 Hz etc. bands.

noise are related to the interaction of the wheels and rails, the most effective means for car-interior noise reduction would be the treatment of rails, say, by applying structural damping through resilient pads under the rail fasteners and/or by using wheel damping treatment or by selecting an optimized trackbed (e.g., ballasted vs concrete). A further, probably very significant, improvement could be achieved through providing the cars with high-transmission loss walls, floors and ceilings, with double glass windows and doors, and with good sealings for doors and windows, in addition to absorptive treatment of car-interior spaces. Most of these "first-choice" techniques require structural modification *on the cars*. However, the present study-effort specifically excludes any modifications on the cars. Rather, all other acoustic techniques are to be considered that promise an improvement of tunnel and station acoustics, and a reduction of radiation efficiency and minimization of structure-borne sound transmission. The goal of this investigation is to define design criteria for quiet (not-car associated) rapid transit system components. Criteria that deal with rails, slabs and station acoustics are reported in companion reports. The report in hand deals specifically with the acoustic treatment of subway tunnels, and provides estimates of the effect of localized treatment on the noise levels *inside* a subway car.

2. PROBLEM DEFINITION

The major transmission paths for acoustic and vibratory energy from outside sources to car-interior spaces are illustrated in Fig. 2. Vibratory energy resulting mainly from wheel/rail interaction travels through the truck into the structural components of the car, which radiate acoustic energy into the car. Control of this path requires vibration-isolation of the truck from the car or the application of damping treatment to various structural members within the car. Vibratory energy also travels through the wheels, rails, and trackbed, which radiates acoustic energy into the tunnel space itself and is transmitted through the car walls or through open windows and ventilation orifices into the car. This mode of energy travel can be affected by absorptive treatment of the tunnel wall surfaces.

In Sec. 1 above, two possible criteria for car-interior noise levels were briefly discussed. These were hearing-damage and speech interference criteria. In order to determine the required amount of noise reduction - by whatever means - one needs to define car-interior noise specifications, that must be weighted against existing levels. Generally, one can state that noise levels should be free from rapidly varying changes as function of speed especially during acceleration and deceleration. Frequently, an NC-55 to NC-65 is recommended for subway car interior noise. PNC-curves* are reproduced in Fig. 3. Comparing these specifications with the existing car-interior levels, as shown in Fig. 1, shows that reductions of 25 to 35 dB over a very large frequency range would be required in the case of the NYCTA system.

*These PNC curves, that differ slightly in shape at the low frequencies from the standardized NC-curves, have not yet been acted upon by any standardization group.

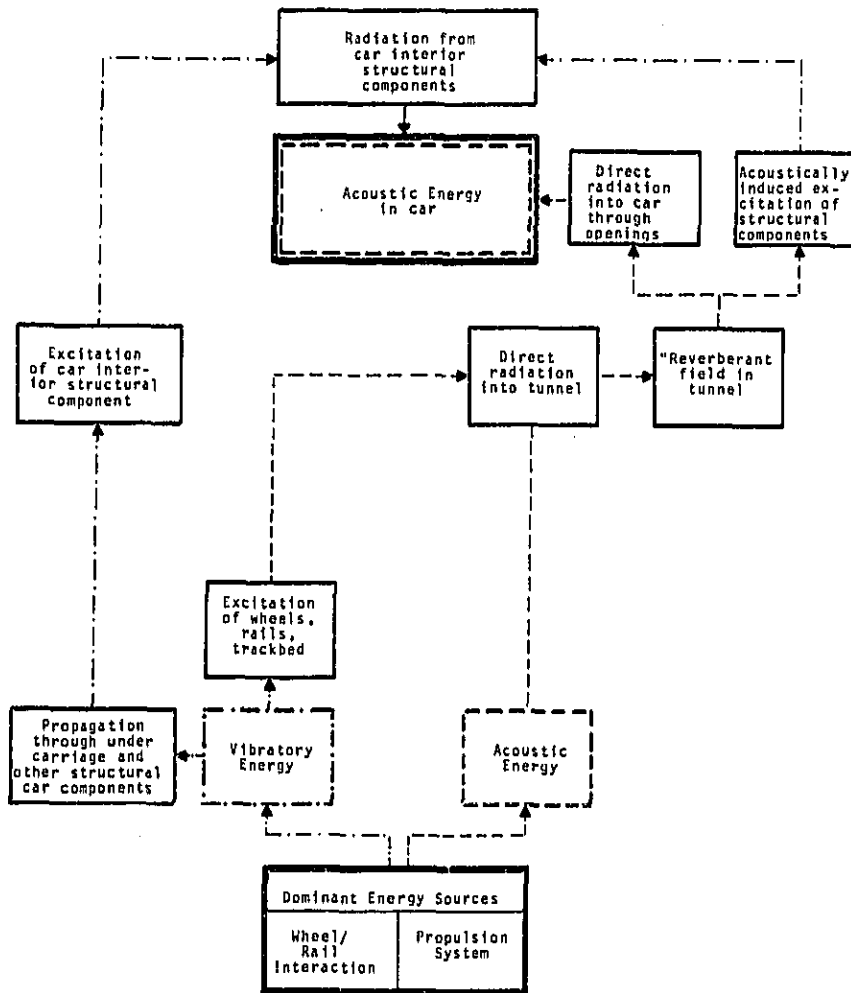

FIG. 2. ENERGY FLOW DIAGRAM FOR SUBWAY NOISE.

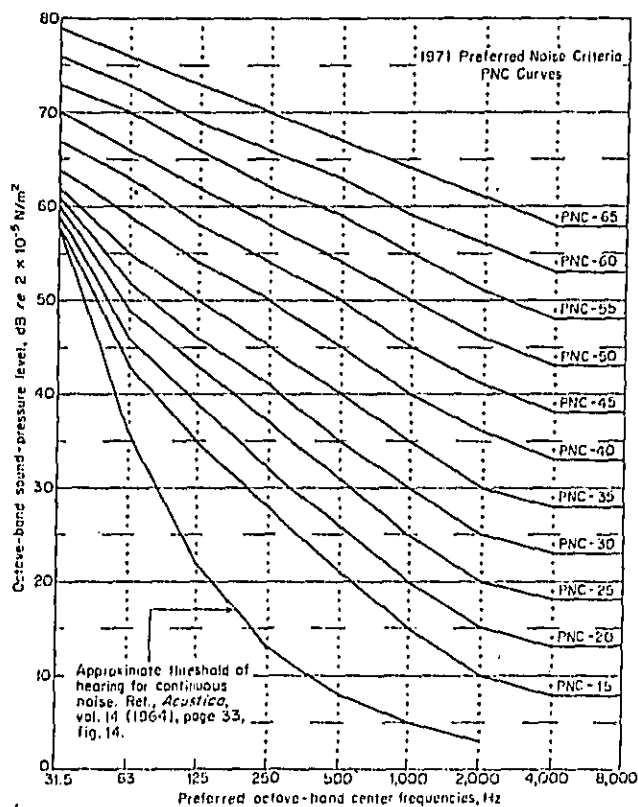

FIG. 3. PREFERRED NOISE CRITERIA (PNC) CURVES (1971). (REPRODUCED FROM BERANEK'S *NOISE AND VIBRATION CONTROL*, MCGRAW-HILL BOOK CO., INC., p. 567.)

The remainder of this report investigates the possibilities and limitations of achieving such a broadband reduction with tunnel acoustic-treatment alone.

BBN conducted acoustic (and other) measurements inside NYCTA system cars as well as outside the trains on (a) tunnel walls and (b) between the rails. These measurements and their implications are discussed in the following section.

3. TEST PROGRAM

3.1 Experimental

In February 1972 acoustic measurements at three locations were conducted within the NYCTA system. Each location typifies a particular environment, namely (1) *inside a tunnel*, i.e., completely enclosed (halfway between Prospect Park and Seventh Ave., 90 ft below Flatbush Ave.), (2) *inside a cut*, approximately 20 ft deep and 50 ft wide, and (3) *on an embankment* along a flat portion with no nearby reflecting surfaces (see Figs. 4 and 5).

These measurements served several purposes. For one, absolute levels inside and outside the car for various environments could be determined. Thus, typical transmission losses for subway car walls were established. Secondly, by comparing car-interior levels measured when the train was inside and outside a tunnel, the effect of tunnel acoustics - reflections in particular - could be established and estimates of the structureborne vs the airborne portion of the car-interior noise could be obtained. Thus, the upper bound effect of tunnel acoustic treatment could be estimated, since, at best, a free-field environment can be generated through tunnel treatment. That portion of the car interior spectrum that remains unchanged must then mostly be attributed to structureborne sources whose energy is propagated along structureborne paths and radiated into the car interior. Of course, any onboard sources, the propulsion system in particular, but also auxiliary equipment will add to car interior noise, but cannot be influenced by treatment of tunnel surfaces.

Appendix A presents (1) A-weighted time histories of the acoustic signals measured inside and outside a car for the three environments and (2) one-third octave band spectra for selected portions of the time-histories (usually at the maximum level of

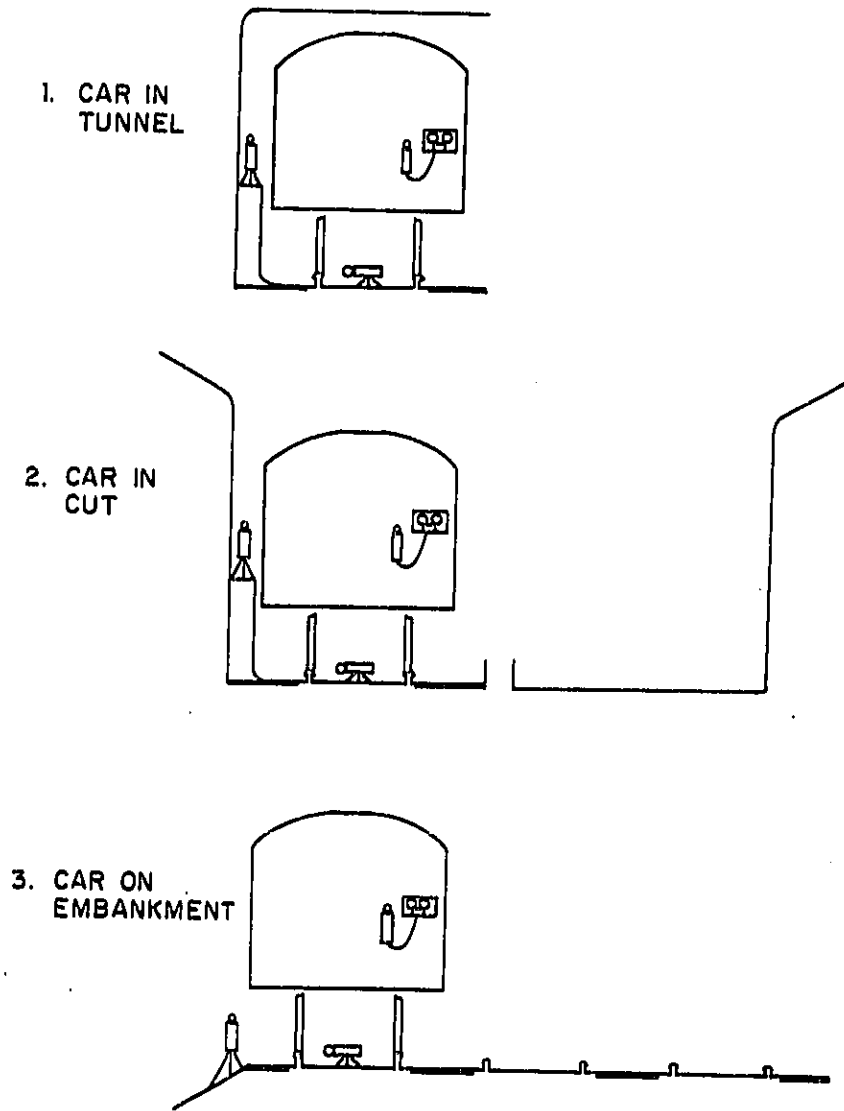
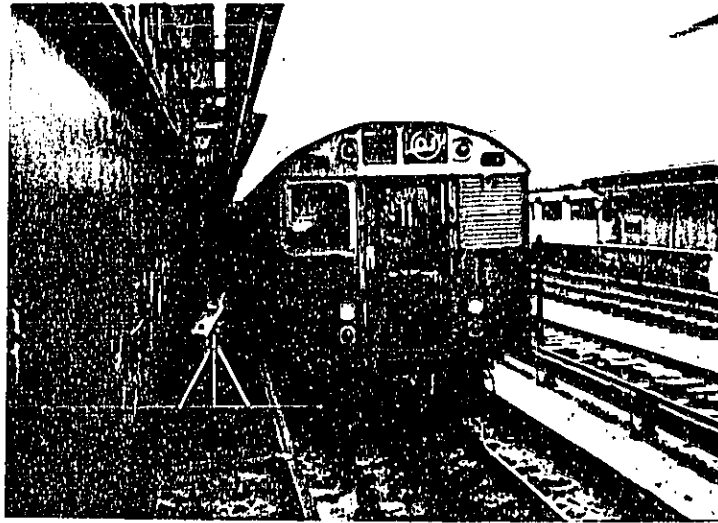

FIG. 4. MEASUREMENT LOCATIONS.

(a)



(b)

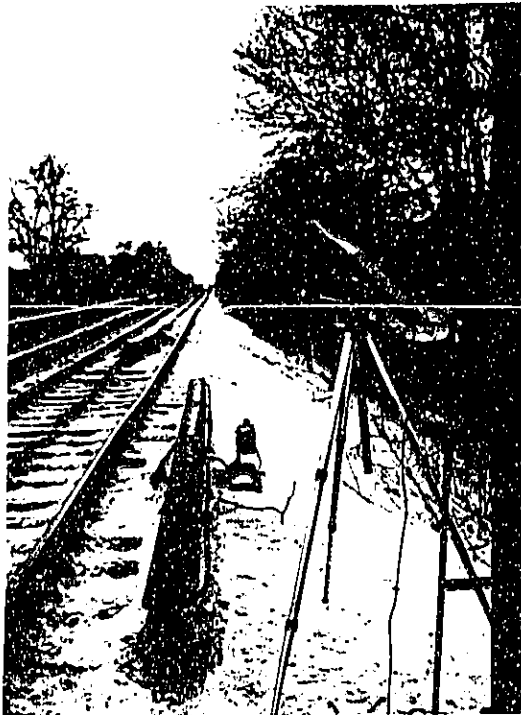

FIG. 5. MEASUREMENT SITES ARRANGEMENTS.

a given time history). In the bulk of this report we will present only those spectra - mostly in normalized form - that are necessary to illustrate conclusions.

3.2 Data Presentation and Discussion

To allow comparison of spectra for various operating conditions and environments, it is necessary to nondimensionalize levels and frequencies. Since train speed is the dominant parameter that affects noise levels, we used this parameter for normalization. Thus all spectra were normalized by the third power of train speed. Frequencies were scaled directly with the ratio of train speeds. Reference speed was arbitrarily selected as 40 ft/sec. This scaling law had also been found in Ref. 1.

For purposes of discussion we use a tunnel/car geometry as illustrated in Fig. 6. We consider four spaces in which a uniform and diffuse sound field is assumed to exist. Space (1) is bounded by the trackbed, car floor, and by the tunnel recess walls; space (2) is essentially the catwalk space in the presence of the car, bounded by car

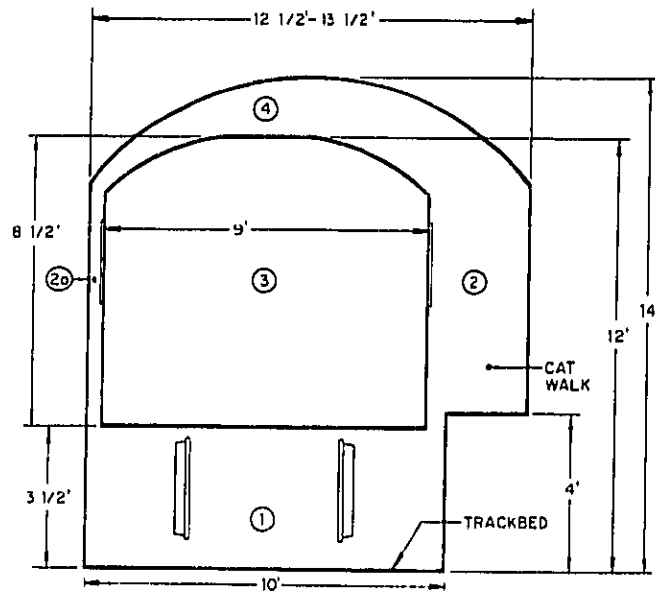

FIG. 6. TUNNEL/CAR GEOMETRY.

wall and tunnel wall; space (2a) is the space on the other side of the car; space (3) is the car interior; and space (4) is above the car roof. Spaces (1) and (2) are connected by an open slot. We assume that noise is generated in space (1) and travels through the slot to spaces (2), (2a), and (4) and from there through the car walls into the car, i.e., space (3).

3.3 Nondimensional Spectra

Figure 7 shows the spectrum measured inside the car in the tunnel for speeds between 27 and 36 mph (40 to 54 ft/sec). Figure 8 shows the spectrum on the tunnel wall (catwalk side), and

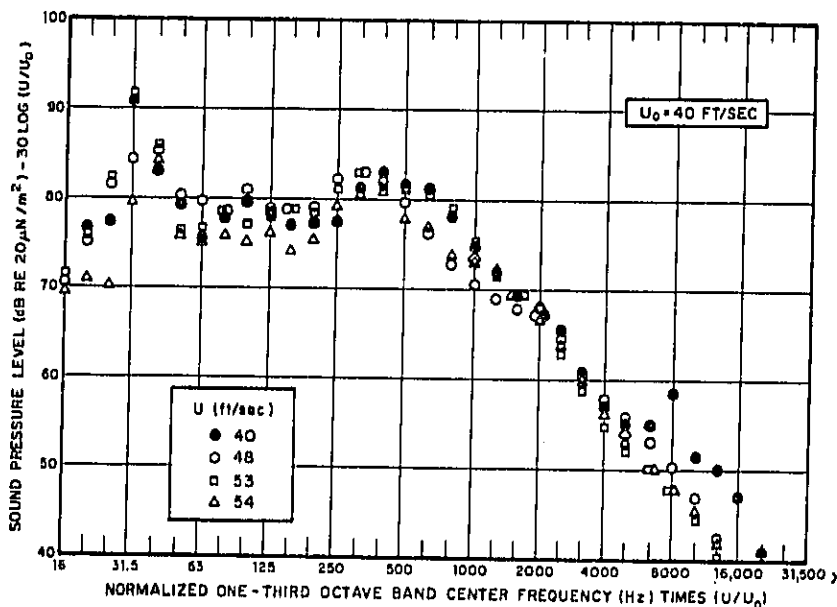

FIG. 7. NORMALIZED SPECTRUM IN CAR, IN TUNNEL.

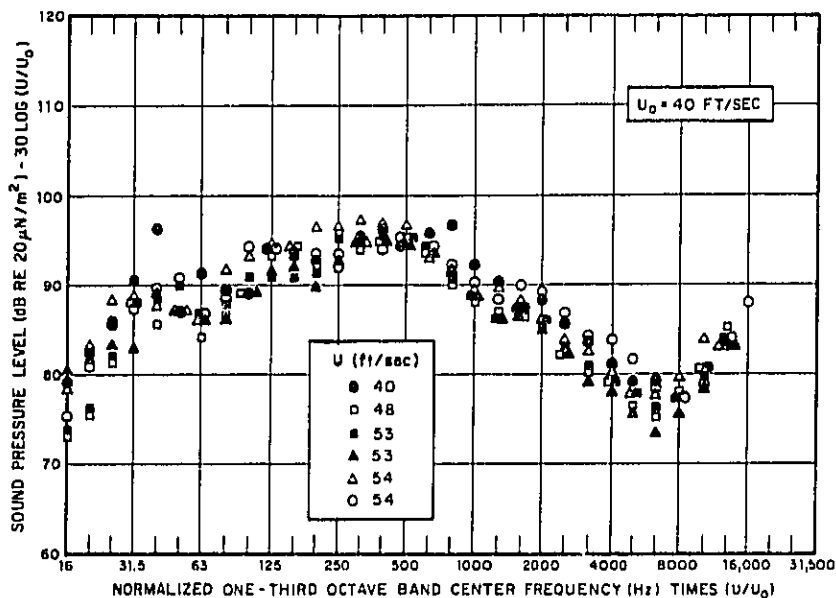

FIG. 8. NORMALIZED SPECTRUM AT WALL, IN TUNNEL.

Fig. 9 shows the spectrum between the tracks. The data points in each of these figures indicate the relatively small scatter over the selected speed range indicating the validity of the "Third Power Law".

3.4 Discussion

The similarity in shape of the normalized spectra measured between the tracks and the catwalk wall indicate that acoustic power travels from the source space (1) through the slot into the space between car side wall and tunnel wall (space 2) with some, almost frequency-independent transmission loss. The pressure levels are lower in space (2) (roughly 5 to 9 dB). Since no

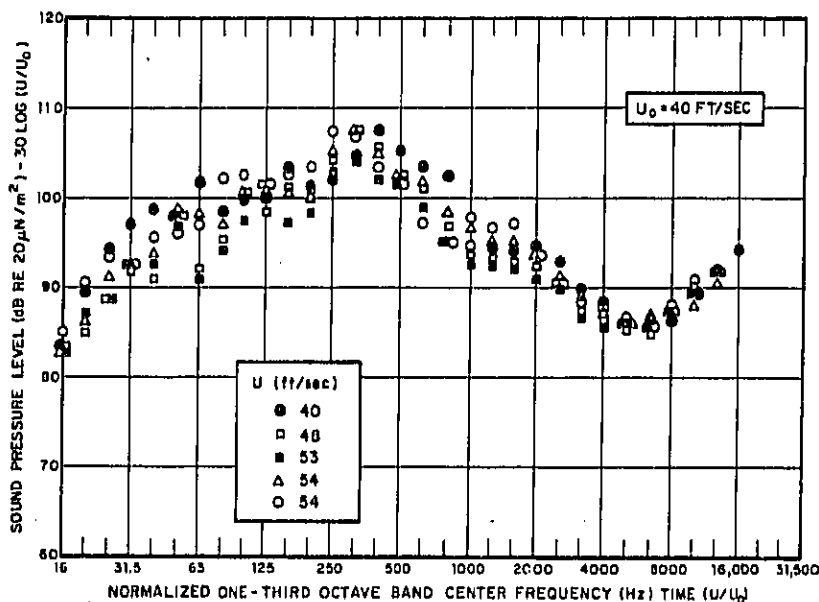

FIG. 9. NORMALIZED SPECTRUM IN TUNNEL, BETWEEN TRACKS.

important sound source is available in space (2) all energy must in fact come from space (1). The sound pressure level observed in the car interior is a result of the acoustic energy transmitted through floor, walls and ceiling. Figure 10 shows the differences between car-interior level and outside levels between tracks. If sound was exclusively travelling through the floor from the "rail/wheel source" then the car interior levels are determined essentially by the floor transmission loss (TL). A representative TL (from Ref. 2) for a typical American railroad car floor as well as the Noise Reduction curve for the NYCTA car floors as derived from the level difference between in-car noise and between-track noise is also shown in Fig. 10. If this NR curve were correct

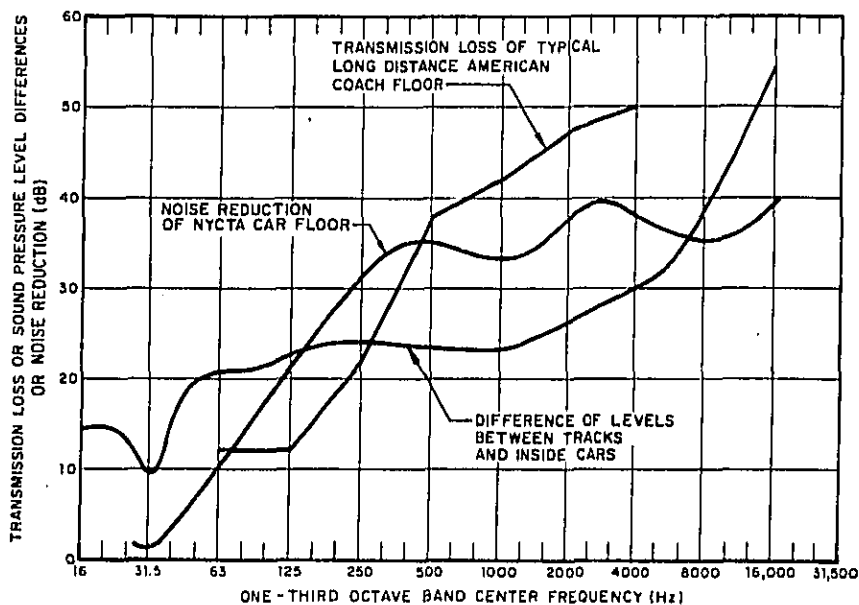

FIG. 10. DIFFERENCE IN CAR EXTERIOR AND CAR INTERIOR LEVEL (ZERO-dB LEVEL).

subway car under consideration, then much lower levels should exist in the car than are actually observed. Figure 11 shows the difference between car interior levels (space 3) and levels in the catwalk area (space 2). If the car walls represent the primary transmission path, then the weaker link - the windows - would determine the effective noise reduction, and the levels in the car. The theoretically derived TL for glass of 1/8-in. thickness is also shown in Fig. 11. The TL curve of 1/8-in. glass must be converted into a noise reduction (NR) curve by accounting for the common wall area through which the sound travels as well as for the acoustic conditions of the receiving space, i.e., the

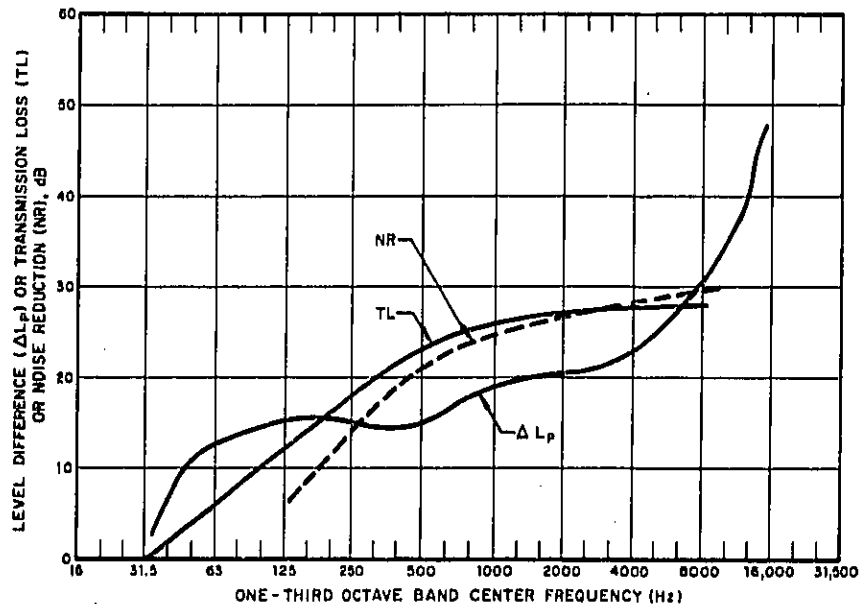

FIG. 11. DIFFERENCE IN CAR EXTERIOR (SPACE 2) AND CAR INTERIOR (SPACE 3) LEVELS AND TRANSMISSIONS LOSS (TL) OF 1/8 IN. THICK GLASS AND SPECIFIC NOISE REDUCTION (NR) FOR WINDOW AREA OF NYCTA CARS.

car-interior. The acoustic conditions of the receiver-space are expressed in terms of a room constant R , which is a function of volume and absorption. Figure 12 shows the relationships of volume and "room-constant" for various room characteristics. Assuming a typical car volume of $60 \times 10 \times 7 \text{ ft}^3$, and qualifying a car-interior as medium-live (in the absence of absorptive treatment) we find a room constant of about 180 ft^2 . Assuming a total glass area of $4 \times 40 \text{ ft}^2$, we obtain from Fig. 13 a correction factor $C = -1 \text{ dB}$ to be used in determining the actual noise

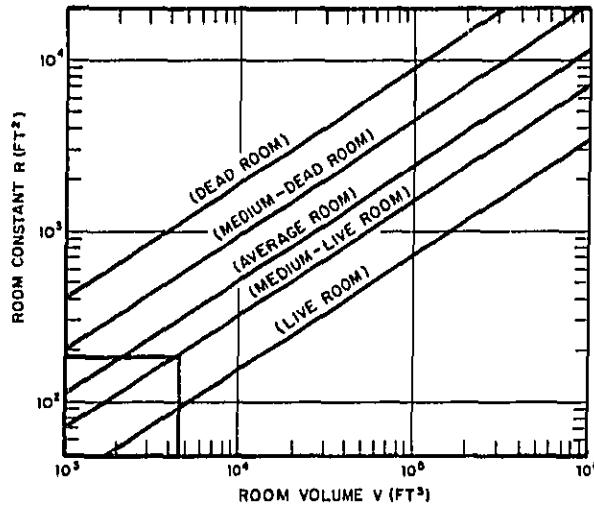

FIG. 12. APPROXIMATE RELATIONSHIP BETWEEN ROOM VOLUME AND ROOM CONSTANT FOR SPACES OF VARIOUS AVERAGE ACOUSTIC ABSORPTION (AT MID-FREQUENCY REGION OF 500-1000 Hz).

reduction from

$$NR = TL + C .$$

C is somewhat dependent on the frequency range; we assume the following corrections:

f (Hz)	< 500	500-1000	> 1000
C	-3	-1	+2

The general trend of the predicted NR-curve compared to the measured level difference supports the assumption of the windows providing the dominant transmission path from space (2) to space

(Select Nearest Integral Value of C)

RATIO S_W/R_2	"C" (dB)	RATIO S_W/R_2	"C" (dB)	RATIO S_W/R_2	"C" (dB)
0.00	+6	1.7	-3	15	-12
0.07	+5	2.2	-4	20	-13
0.15	+4	2.9	-5	25	-14
0.25	+3	3.7	-6	31	-15
0.38	+2	4.7	-7	40	-16
0.54	+1	6.1	-8	50	-17
0.75	0	7.7	-9	63	-18
1.0	-1	9.7	-10	80	-19
1.3	-2	12	-11	100	-20

S_W is the area of the wall or floor (in sq ft) common to the "transmitting" and "receiving" rooms.

R_2 is the Room Constant of the "receiving" room; include low frequency values of R_2 .

FIG. 13. APPROXIMATE WALL OR FLOOR CORRECTION TERM "C" FOR USE IN THE EQUATION $NR = TL + "C"$.

(3). However in the medium frequency range, say, between 250 and 6000 Hz, there is "excess sound" in the car. The reason could be three-fold: (1) there are direct openings in the car structure - and they may be in the floor, walls or ceilings - through which energy enters the car virtually unattenuated from the outside; (2) car-internal sources dominate the spectrum in the 250 to 6000 Hz range; (3) vibration-induced energy from wheel/rail interaction or the propulsion system propagates along structural paths and reradiates as acoustic energy into the car. For the latter two cases, tunnel treatment will have no effect on the levels observed in this frequency range. Comparison of car-interior

spectra measured when the car is inside and outside a tunnel in a "free-field environment" (Fig. 14) shows common levels below 125 Hz. As stated previously, the upper bound noise reduction that can be achieved through tunnel treatment is basically given by the "noise-floor" in the car when traveling in a free-field environment. Figure 15 compares the spectra measured between the rails inside and outside the tunnel. The in-tunnel trackbed was concrete, outside the tunnel it consisted of 2-in. diam. granite aggregate. Although levels outside the tunnel are lower - as expected - the effects of the (1) free-field vs reverberant field and of (2) concrete vs ballast trackbed cannot be separated from

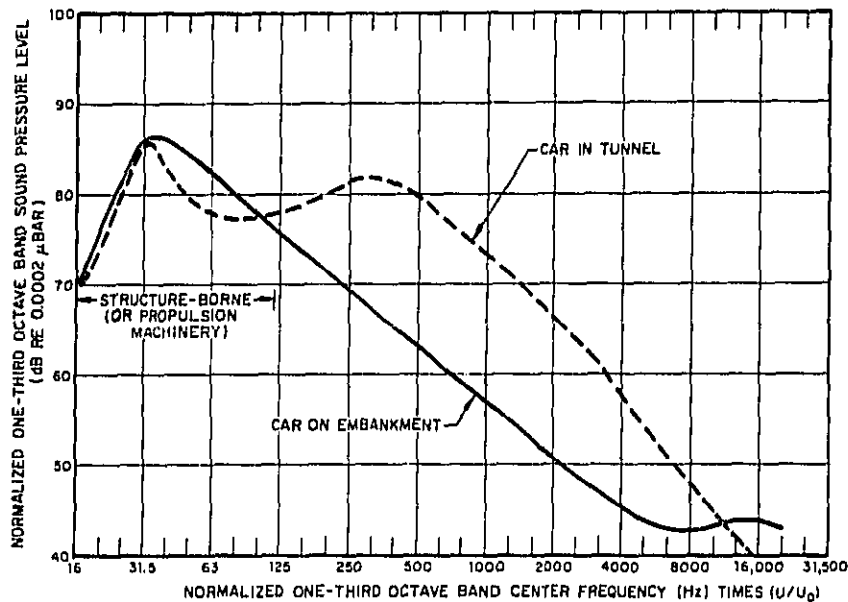

FIG. 14. COMPARISON OF CAR-INTERIOR SPECTRA FOR TWO CONDITIONS.

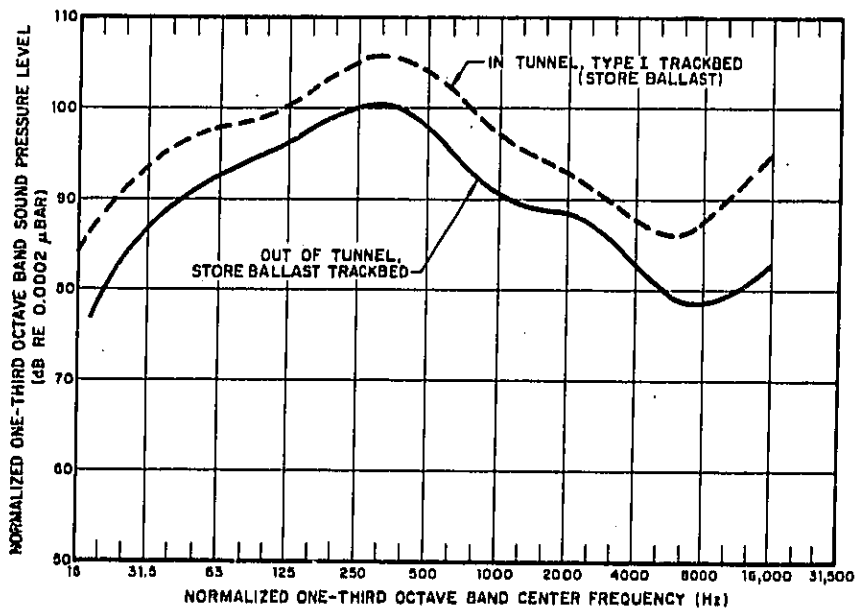

FIG. 15. COMPARISON OF SPECTRA BETWEEN RAILS.

the information in Fig. 15. In both cases the spectral shape is identical, suggesting that the first effect is the relevant one.

The airborne portion of the wheel/rail interaction noise can be positively affected by changing from a concrete to a ballasted trackbed. The car-interior spectrum measured outside the tunnel, representing a lower bound, would still exceed the PNC-65 curve at frequencies below 800 Hz. Thus to achieve a noise environment to satisfy this criterion it does not suffice to treat the tunnel; rather one must control structureborne sources, or treat the car interior spaces with absorptive wall material.

4. TUNNEL ABSORPTIVE-TREATMENT

In this section the effectiveness of various levels of absorptive treatment concepts for tunnel surfaces are evaluated.

4.1 Trackbed

Regular concrete trackbed surfaces provide an almost fully reflecting surface for acoustic energy. However, lining the trackbed with sound-absorptive material (as sketched in Fig. 16) will reduce tunnel noise. Use of usual gravel (about 2 in. diam) will only slightly reduce the sound pressure levels in "space 1" for a given power level spectrum, since typical absorption coefficients are quite low, on the order of 0.1 to 0.2 over the frequency range of interest. Use of smaller gravel sizes or of porous concrete will improve the absorptive properties of the trackbed. Below, absorption coefficients are tabulated for gravel of various sizes, as well as of porous concrete.

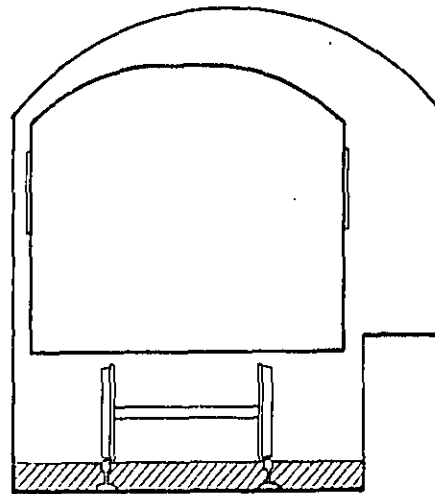

FIG. 16. TRACKBED LINING.

In general, smaller gravel sizes increase the absorption coefficients. Thus, a 6-in. layer of 1/4-in. granite aggregate provides very high absorption over the frequency range 250 to 4000 Hz. Such small-size gravel may be impractical and cellular concrete might be preferable, providing about the same absorption

TABLE I. ABSORPTION COEFFICIENTS

Material	Frequency (Hz)					
	125	250	500	1000	2000	4000
1-1/4-in. granite aggregate, 6 in.	0.06	0.11	0.46	0.40	0.35	0.46
3/4-in. or less, granite aggregate, 4 in.	0.14	0.18	0.52	0.34	0.83	0.54
3/4-in. or less, granite aggregate, 6 in.	0.12	0.10	0.62	0.57	0.76	0.96
3/4-in. or less, granite aggregate, 8 in.	0.15	0.44	0.35	0.85	0.50	0.49
1/2-in. or less, granite aggregate, 6 in.	0.15	0.30	0.67	0.37	0.78	0.64
1/4-in. or less, granite aggregate, 6 in.	0.22	0.64	0.70	0.79	0.88	0.72
Rough nonporous concrete	0.02	0.02	0.04	0.06	0.08	0.10
Cellular concrete, 1-in. thick	0.13	0.14	0.38	0.60	0.64	0.52

as a 4-in. layer of 3/4-in. size granite aggregate. Suppose then the entire trackbed width was treated with an absorptive layer (Fig. 17). What would the effect on the sound pressure level in space (1) be? Since the only quantity that changes is the absorptive coefficient, not however the geometry, we can determine the decrease in sound pressure level for a given power level. From simple geometric considerations the ratio of sound pressures can

be computed as

$$(p_1/p_2)^2 = [W(\alpha_2/\alpha_1) + W + 2H]/(2W + 2H) ,$$

where W is the width and H is the height of the trackbed recess. For the specific width W and height H of the trackbed recess we obtain the difference in sound pressure level as

$$\Delta L_p = 10 \log \left(17 + 10 \frac{\alpha_2}{\alpha_1} \right) - 14.3$$

where α_1 = original (lower) absorption coefficient

α_2 = new (higher) absorption coefficient.

This equation is graphically presented in Fig. 18.

For example, assume that the originally nonporous concrete trackbed is covered over its entire width of 10 ft with a 4 in. layer of 3/4 in. sized granite aggregate. Then, the following sound pressure level reductions ΔL_p in space (1) should be expected:

Frequency, Hz	125	250	500	1000	2000	4000
ΔL_p	6	6	7.5	5	7	4

These results are rather impressive. It should be noted, however,

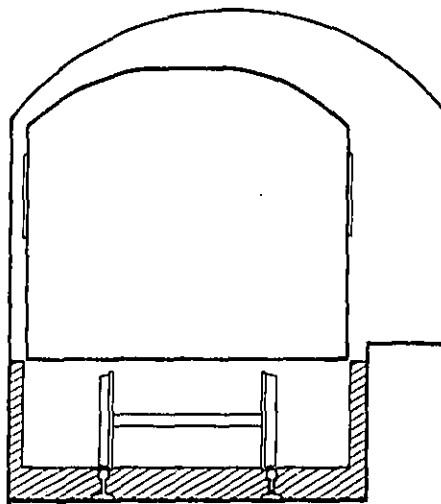

FIG. 17. COMPLETE TREATMENT OF TRACKBED RECESS.

that they are based on the assumption that all four surfaces, bounding space (1), are essentially hard-reflecting (i.e., $\alpha \approx 0.01 - 0.1$). Thus, introduction of absorptive material even on one wall only will have a substantial effect. Furthermore, since the decisive quantity is the ratio of absorption coefficients, the improvement depends entirely on the original state of the four boundary walls. Realistically, the recess-walls and the underside of the car-floor may in effect have a higher absorption than the original nonporous tracked floor, which would reduce the improvement. Furthermore the upper surface of space (1) has openings on both sides leading to spaces (2a) and (2); such openings have an absorption coefficient of unity, and result in a higher *initial* absorption coefficient, degrading the effect of increased tracked absorption.

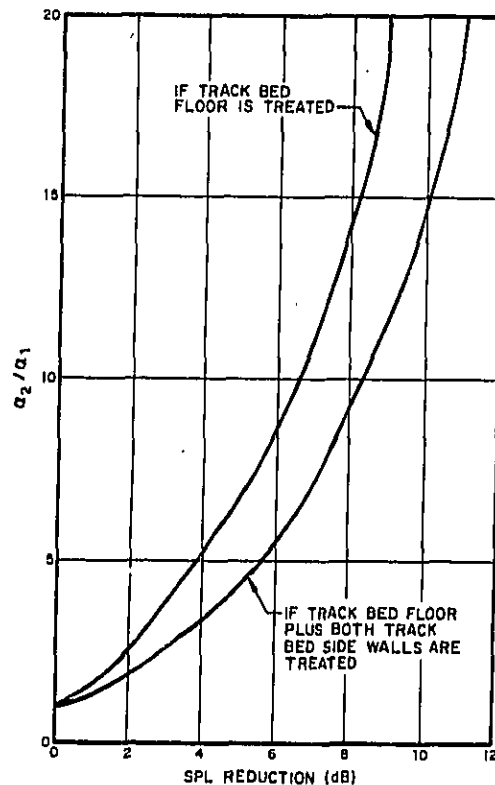

FIG. 18. REDUCTION IN SOUND PRESSURE LEVEL (SPL) WHEN ABSORPTION COEFFICIENT OF TRACKBED IS CHANGED FROM A LOW VALUE α_1 TO A HIGH VALUE α_2 , FOR THE SPECIFIC TUNNEL GEOMETRY SHOWN IN FIG. 6.

4.2 Side Walls of Trackbed Recession

Further improvement should occur if in addition the side walls of the trackbed recession were treated (Fig. 17).

Let us assume a common new absorption coefficient for trackbed and trackbed recess walls, α_2 , vs the original coefficient α_1 . Similar simple geometric considerations lead to the ratio of original to new sound pressure

$$\left(\frac{p_1}{p_2}\right)^2 = \frac{(\alpha_1/\alpha_2)(2H+W) + W}{2W + 2H}$$

or in logarithmic form for the specific dimensions of the trackbed recess

$$\Delta L_p = 10 \log \left(17 \frac{\alpha_2}{\alpha_1} + 10 \right) - 14.3$$

where ΔL_p is the difference in sound pressure level in dB.

This latter equation is also presented in graphic form in Fig. 18.

For example, assume the original nonporous trackbed being covered with a 4 in. layer of 3/4 in. sized granite aggregate. Also, the walls are covered with absorptive material having the same absorption properties as the gravel. Then the following total reduction in sound pressure level should result:

Frequency, Hz	125	250	500	1000	2000	4000
ΔL_p	8	8	9.5	7	9	6

The same qualitative remarks as advanced in Sec. 4.1 apply here also, namely that in practical cases a deterioration of these improvements is likely due to the discontinuities in the "fourth wall". Most importantly, however, at low frequencies the sound field in the spaces considered is not diffuse, as had been assumed in the above calculations.

4.3 Tunnel Side Walls

In estimating the effect of absorptive treatment of the tunnel side walls we can consider space (2a) between the car side walls and tunnel walls as a duct, that carries acoustic energy from the source up towards the windows. Let us first consider the effect of lining the tunnel wall of space (2a) with a 3 in. thick absorptive lining, reaching up to the window level (Fig. 19). We assume the clearance between tunnel wall and lining surface to be 1 ft.

From Fig. 20, which shows the attenuation per foot of duct length for various combinations of duct width and treatment depth, we may expect an attenuation for, say, a 4 ft high wall treatment as follows:

Frequency, Hz	63	125	250	500	1000	2000	4000
Attenuation, dB	0	1.5	4	6	6	2	0

If a 6-in. thick treatment were possible, leaving 6 in. free space between treatment surface and car wall then up to 13 dB attenuation at 500 Hz are to be expected. If instead of 4 ft from the line of the car floor up to the end of the absorptive lining, 6 ft were used, these values would increase by a factor of 1.5.

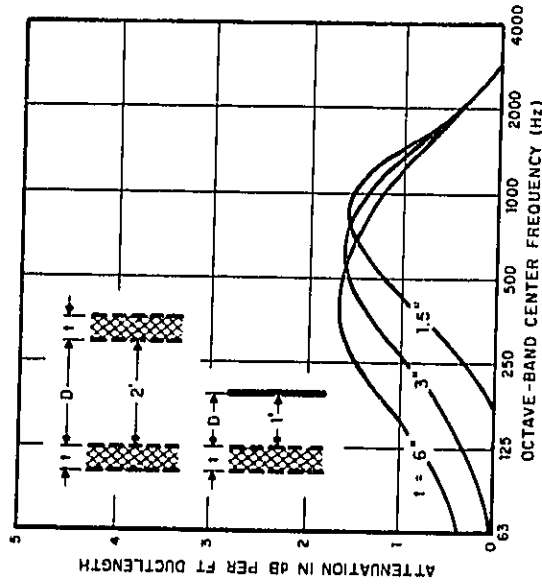

FIG. 20. ATTENUATION IN A DUCT PER FOOT OF DUCT LENGTH, FOR THICKNESS t OF ABSORPTIVE LAYER, WITH $D = 2$ FT AND TWO OPPOSING SIDES ABSORPTIVE-LINED, OR $D = 1$ FT WITH ONE SIDE ABSORPTIVE-LINED AND OPPOSING SIDE ACOUSTICALLY HARD

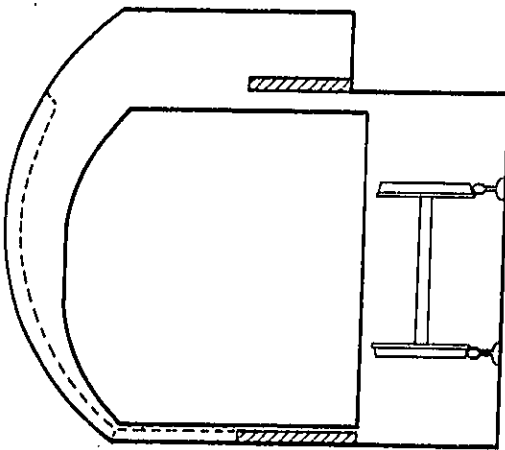

FIG. 19. TREATMENT OF SIDE WALL CEILING AND "BANISTER CONSTRUCTION".

On the other side of the car, (space 2), the space between car side wall and tunnel wall of about 2-1/2 ft would provide very little "duct attenuation", even for relatively large lining thickness. However, if a banister construction were erected at the cat walk rim (as sketched in Fig. 19), that would duplicate the design on the other side, then similar "duct-attenuations" could be expected. It should be realized, though, that wall treatment on the far side of the catwalk will affect the acoustics of the tunnel by virtue of reducing the reverberation time and thus lowering the levels in space (2). If only space (2a) is treated, the effect on car-interior noise will be only very small.

The effect of these "two-dimensional duct mufflers" will, in practice, not be as large, since sound will travel from the wheel/rail location up in the spaces between successive cars. This airpath will heavily deteriorate the attenuation provided by wall or banister linings.

4.4 Tunnel Ceiling

If acoustical treatment is extended up along the side walls and along the tunnel ceiling, one could again consider the space between the car walls and ceiling, as a muffled duct within which sound pressure levels decrease with distance from the source. Thus, assuming the same wall treatment, as schematically shown in Fig. 19 (3 in. lining, 1 ft free space), one would expect the levels up above the car and below the tunnel ceiling (space 4) assuming an effective "duct length" of 12 ft to be attenuated by about 18 dB in the 500 Hz range with zero-attenuation at and below 63 and at and above 3000 Hz. However, the bend in the duct will provide some extra attenuation of about 10 dB above 500 Hz.

Generally, wall and ceiling treatment would attenuate sound traveling from space (1) towards space (2) via spaces (2a) and (4) by the following amounts:

Frequency, Hz	63	125	250	500	1000	2000	4000
Attenuation, dB	0	6	12	17	16	10	10

More sound would, of course, enter space (2) through the slot between spaces (1) and (2), so that - from the point of duct attenuation a ceiling treatment would represent an overdesign. However, an important aspect of getting treatment lies in the reduction of tunnel reverberation time, which will, for a given power level, reduce the sound pressure level in the tunnel.

4.5 Catwalk Treatment

Treatment of the catwalk wall will have a similar effect, as treatment of the trackbed width, in that the sound pressure levels will be reduced in space (2) (Fig. 21). Considering space (2) only, one can predict the improvement due to absorptive wall treatment from

$$\left(\frac{P_1}{P_2}\right)^2 = [H_c(\alpha_2/\alpha_1) + H_c + 2W]/(2H_c + 2W)$$

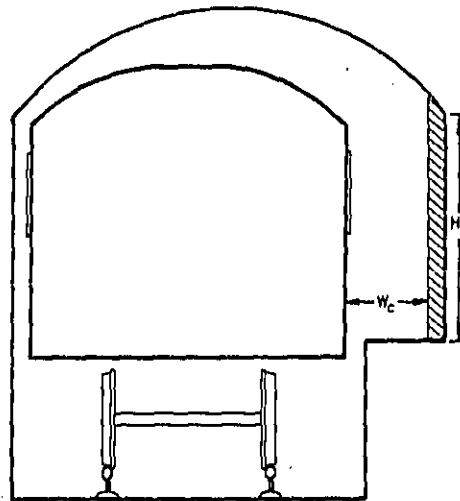

FIG. 21. TREATMENT OF CATWALK SIDEWALL.

where H_c (≈ 9 ft) is the height of the catwalk space, and W ($\approx 2\frac{1}{2}$ ft) is its width. For the *specific* dimensions, as shown in Fig. 5, we obtain the following pressure level difference, as function of absorption coefficient before and after the treatment application

$$\Delta L_p = 10 \log [9(\alpha_2/\alpha_1) + 14] - 13.6 .$$

Figure 22 presents this equation in graphical form.

Assume, for example, that a 2-in. thick porous rigid glass fiber foam board was mounted directly onto the hard wall [2]. The hard wall (as all other boundary surfaces) is assumed to have an original absorption coefficient of α_1 . This fiber glass arrangement would have absorption coefficients, α_2 . The following noise reductions could be expected:

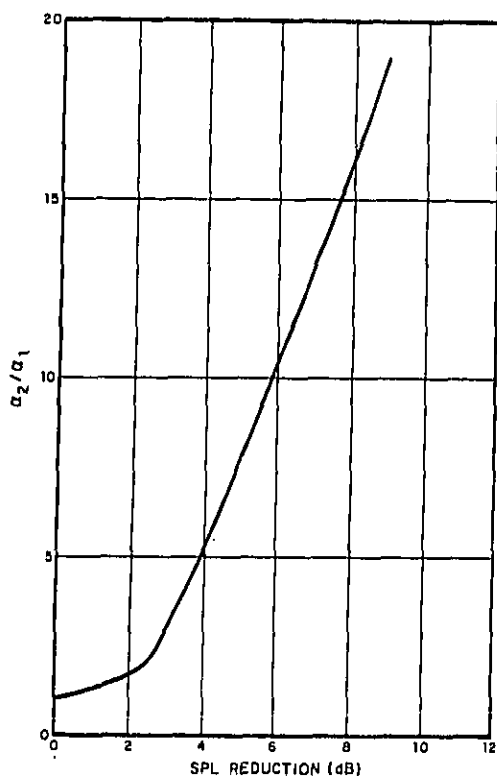

FIG. 22. REDUCTION IN SOUND PRESSURE LEVEL (SPL) WHEN ABSORPTION COEFFICIENT OF CATWALK WALL IS CHANGED FROM A LOW VALUE α_1 TO A HIGH VALUE α_2 , FOR THE *SPECIFIC* GEOMETRY SHOWN IN FIG. 6.

Frequency, Hz	125	250	500	1000	2000	4000
α_1	0.05	0.05	0.05	0.05	0.05	0.05
α_2	0.4	0.6	0.9	0.9	0.9	0.9
ΔL_p	5.5	7	9	9	9	9

Again, it should be realized that these improvements would only occur if all original boundaries of the surfaces, terminating the catwalk, were hard-reflecting surfaces of an average absorption coefficient of 0.05. This condition does not hold for the top surface, which - in fact - is "open" towards the tunnel ceiling [space (4)].

4.6 Estimate of Combined Effect of Tunnel Treatment

Using the approximate calculations, and materials discussed in the previous sections (4.1 to 4.5), the combined effect on the car interior noise levels of tunnel treatment is estimated below (see Fig. 23). Figure 24 illustrates the reductions in noise level in successive steps, starting with the original trackbed spectrum. In arriving at the car interior spectrum (for a train-speed of 35 mph) it was assumed that the tunnel has initially hard reflecting surfaces, and that

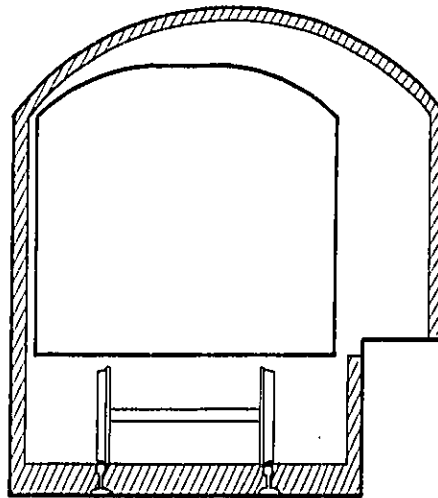

FIG. 23. COMPLETE TREATMENT OF TUNNEL SURFACES.

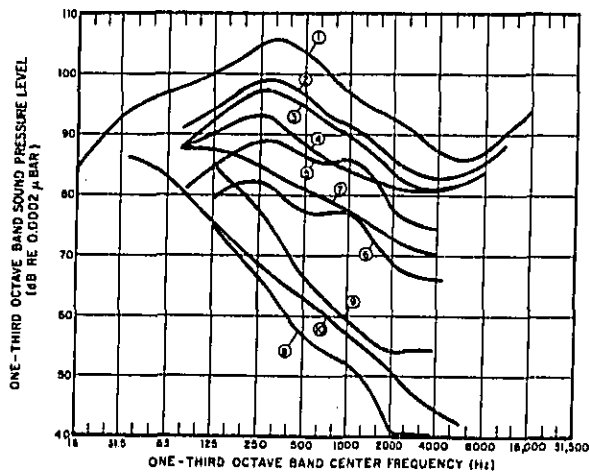

FIG. 24. ILLUSTRATION EXAMPLE OF EFFECT OF TUNNEL AND TRACKBED ACOUSTIC TREATMENT ON CAR-INTERIOR NOISE SPECTRUM. FOR LEGEND SEE TEXT.

from the source in space (1) sound travels exclusively along airborne paths into the spaces surrounding the car, and from there through the windows into the car. The following legend applies to Fig. 24.

1. Original spectrum in space (1) (tracked).
2. Space (1) spectrum after treatment of tracked floor with porous concrete.
3. Space (1) spectrum after treatment of tracked floor and sidewalls with porous concrete and a 2-in. fiberglass foam board, respectively.

4. Space (2a) spectrum, when tunnel wall is covered with a 3-in. layer of fiberglass, leaving a 1 ft space between fiberglass surface and car wall.
5. Space (2) spectrum, where space (2) is not treated, but space (1) is treated according to step (3) above.
6. Space (2) spectrum, where space (2) side wall is covered with a 2-in. thick layer of fiberglass, in addition to space (1) treatment according to step (3) above.
7. Space (4) spectrum, when space (2a) wall and space (4) wall (i.e., tunnel ceiling) is covered with 3-in. thick layer of fiberglass, in addition to space (1) treatment according to step (3) above.
8. Car-interior spectrum if sound enters from space (2) [in condition of step (6) above] through 1/8-in. thick glass windows.
9. Car interior spectrum if sound enters from space (2a) [in condition of step (4) above] through 1/8-in. thick glass windows.
10. Car interior spectrum measured for train outside tunnel (from Fig. 14).

Comparison of the spectra predicted in the car for the treatments discussed above, with the in-car spectrum measured for train outside the tunnel shows gratifying agreement in the frequency range above 125 Hz.

5. RECOMMENDATIONS

It should be emphasized that absorptive treatment of tunnel and trackbed surfaces must be supplemented by controlling structureborne and airborne paths on the car itself to minimize re-radiation of vibratory energy from wheel/rail interaction as acoustic energy into the car. As mentioned previously, tunnel treatment will control only one particular airborne path of acoustic energy. Onboard sources are, of course, not affected by tunnel treatment. If the cars are not modified, then, at best, a reduction of about 10 to 15 dB in the frequency range of 250 to 4000 Hz can be achieved through a tunnel treatment that provides essentially free-field conditions. If acoustic energy in the car propagates solely through airborne paths from space (1), the trackbed area, via spaces (2a) (between car wall and tunnel wall) or (2) (catwalk) through the windows, then the following qualitative improvement could be expected by the following treatments.

a. Treatment of trackbed width with porous concrete or small size granite aggregate would lower SPLs by up to 5 dB over a large frequency range, provided the original trackbed was non-porous, hard reflecting concrete.

b. Additional treatment of trackbed sidewalls with porous concrete, or 2-in. thick Neoprene coated duct-liner board with a density of approximately 3 lb/cu ft (e.g., Owens Corning Fiberglas type 703) in direct contact with the trackbed walls, would reduce levels over a broad frequency range by an additional 2 to 3 dB, especially at the higher frequencies.

c. Treatment of the narrow space formed by the car wall and the directly adjacent tunnel wall with a layer of 3-in. thick duct liner board as under (b) above. This would reduce levels at the

windows through the effect of "duct-absorption" by about 5 dB between 250 and 1000 Hz. However, this measure must be complemented by

d. Treatment of catwalk walls, since otherwise sound from the cat walk space will enter the car and dominate sound transmitted through the other car wall. Catwalk treatment with similar material as described in (3) above, will reduce sound pressure levels in the catwalk space by 5 dB at 125 Hz, rising to 8 dB at 4000 Hz.

Similarly, catwalk treatment by itself would show little effect, unless complemented by absorptive treatment of the narrow space between car and tunnel on the other side, i.e., space (2a).

e. Treatment of tunnel ceiling will generally reduce sound pressure levels in the entire tunnel cross-section (as does the treatment of the catwalk wall) but, more importantly, by forming an absorptive (two-dimensional) duct between car roof and tunnel ceiling, reduce the amount of acoustic energy in the catwalk space that travels up along the far wall of the car and over its roof towards the catwalk space.

f. In general, if the tunnel has originally only hard reflecting surfaces then application of absorptive material to any surface will have a marked effect. Increasing successively the amount of absorption will have a lesser and lesser effect on a proportionate basis.

g. For cost reasons one could compromise in providing heavy treatment, along all tunnel surfaces only at the first 100 ft or so after a tunnel entrance, whereafter the amount of surface treatment would be reduced further inside the tunnel. This would prevent the startling and sudden increase in car-interior sound level at the instant of entering a tunnel.

h. Although complete treatment of tunnel surfaces would provide a noise reduction of 25 to 45 dB from between-track noise to car-interior noise, such a high reduction is, in practical cases, not achieved due to the structureborne transmission paths through which substantial portion of energy is transmitted into the car interior spaces.

Considering the noise spectrum in the car when the train is traveling on an embankment as lower bound, then, clearly, there is no point in providing more absorptive treatment on the tunnel walls than necessary to achieve this limiting spectrum. From Fig. 14 it is obvious that noise reduction of about 15 dB over a frequency range from about 250 Hz to 4000 Hz would be necessary to achieve this goal. Treatment of trackbed floor and side walls will provide about 8 dB over the desired frequency range. Treatment of the tunnel wall next to the car wall and providing an absorptive banister on the cat-walk side would further reduce the car-interior levels by up to 7 dB, providing a total of up to 15 dB. The change in car-interior levels due to these measures are qualitatively shown in Fig. 22 for four conditions: train (1) in untreated tunnel, (2) and (3) in partially treated tunnel, and (4) on an embankment.

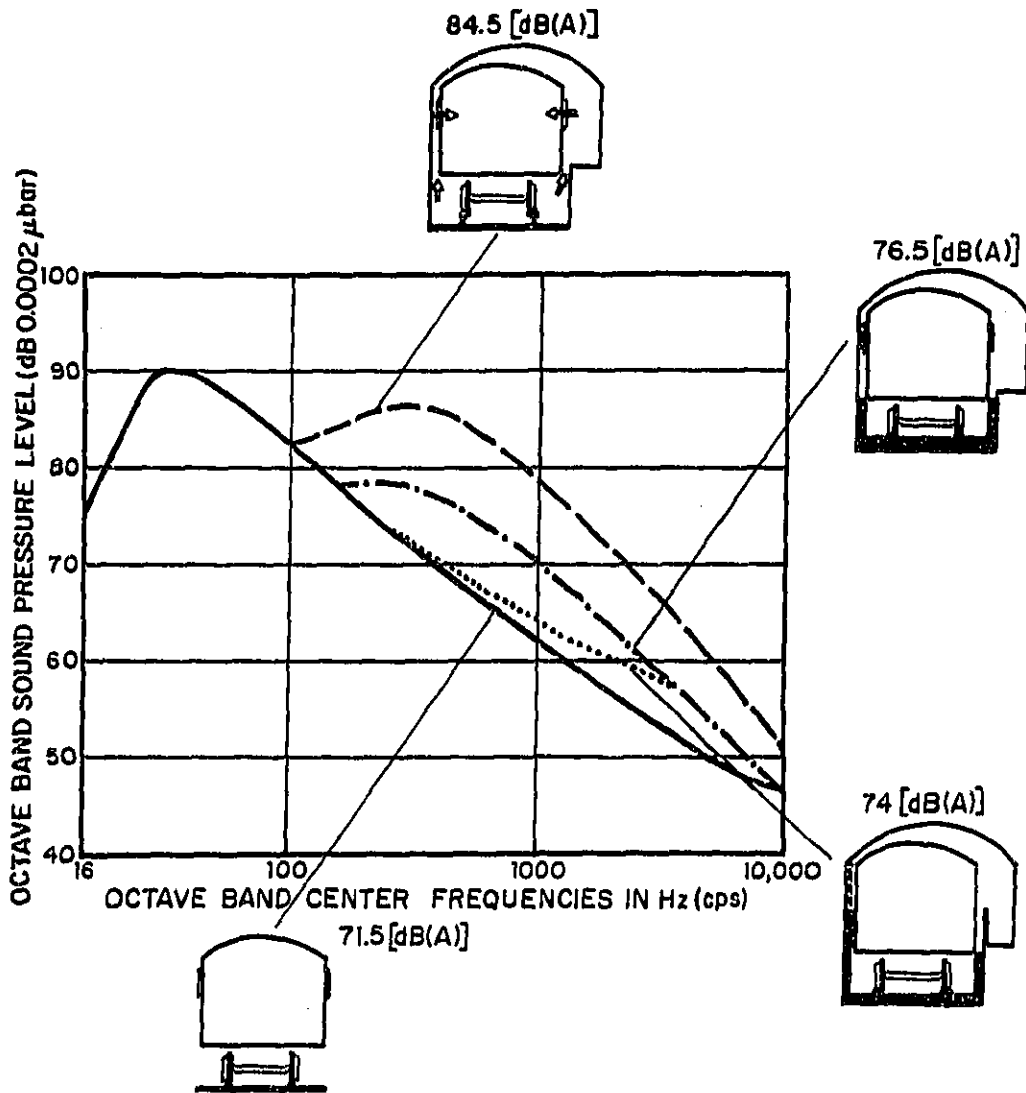

FIG. 25. CAR-INTERIOR NOISE LEVELS FOR THE FOLLOWING CONDITIONS: TRAIN (1) IN UNTREATED TUNNEL, (2) AND (3) IN PARTIALLY TREATED TUNNEL, AND (4) ON EMBANKMENT.

Report No. 2391

Bolt Beranek and Newman Inc.

REFERENCES

1. "Noise and Vibration Characteristics of High Speed Transit Vehicles", Wilson, Ihrig & Assoc., Inc. Tech. Report No. OST-ONA-71-7.
2. L.L. Beranek, Ed., *Noise Control*, John Wiley & Sons, Inc., New York, New York, 1960.

Report No. 2391

Bolt Beranek and Newman Inc.

APPENDIX A
REPRESENTATIVE ACOUSTICAL DATA OBTAINED ON
THE NYCTA SUBWAY SYSTEM

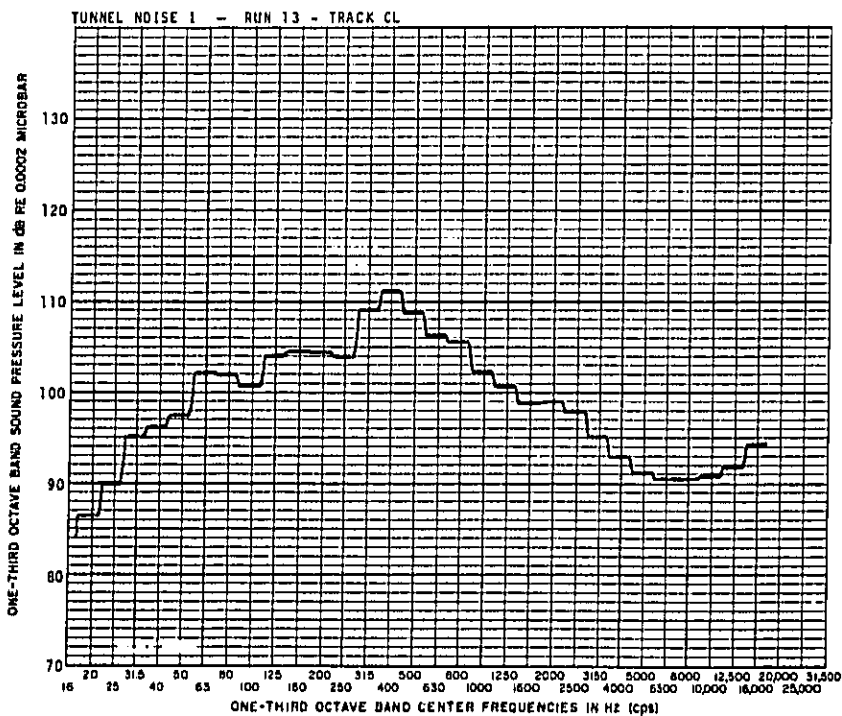
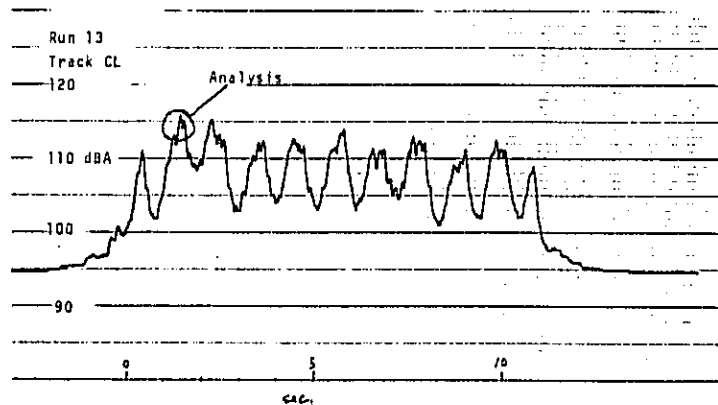

FIG. A-1. TIME HISTORY AND ONE-THIRD OCTAVE BAND SPECTRUM OF NOISE MEASURED BETWEEN THE RAILS FOR A TRAIN TRAVELING IN A TUNNEL AT 35 MPH.

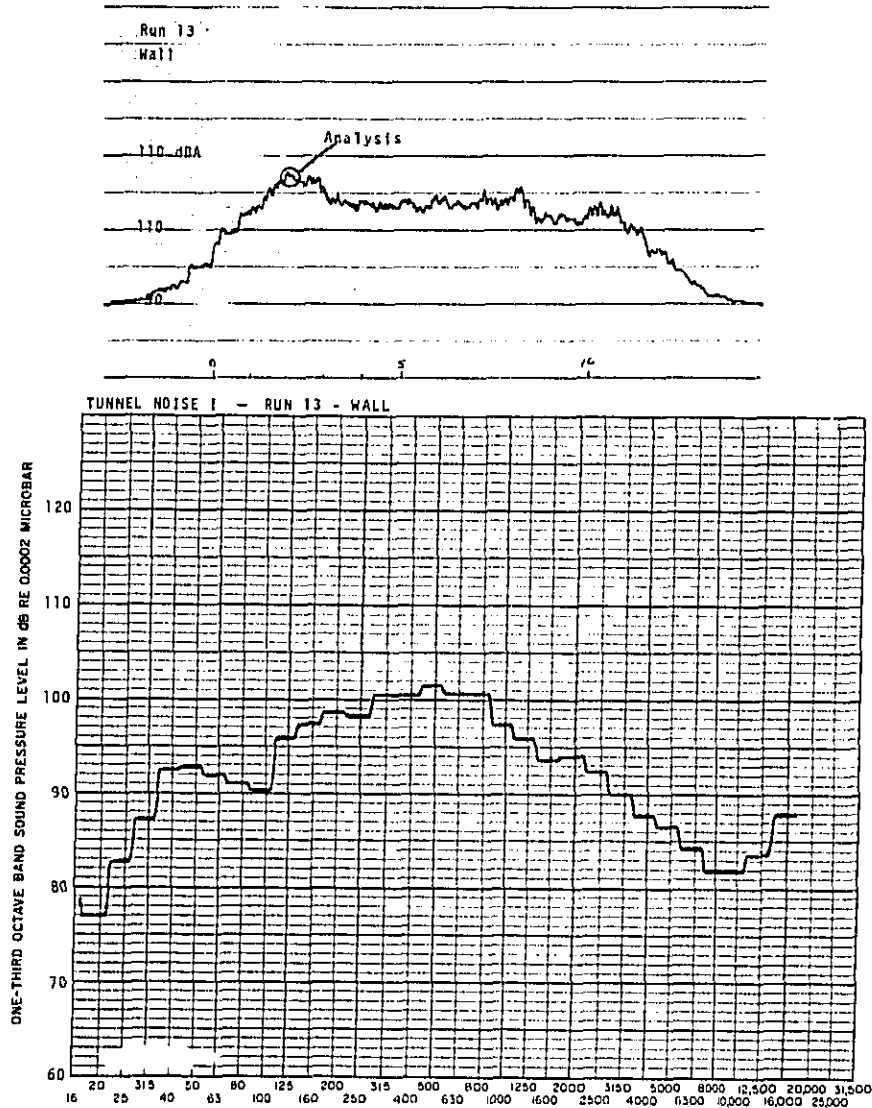

FIG. A-2. TIME HISTORY AND ONE-THIRD OCTAVE BAND SPECTRUM OF NOISE MEASURED ON THE CATWALK FOR A TRAIN TRAVELING IN A TUNNEL AT 35 MPH.

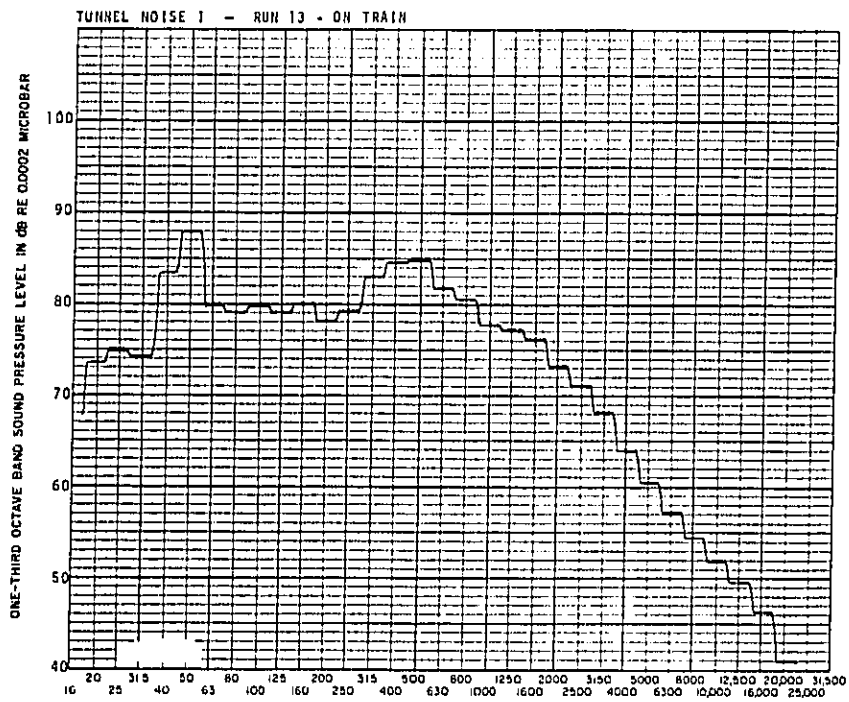

FIG. A-3. ONE-THIRD OCTAVE BAND SPECTRUM OF NOISE MEASURED IN THE TRAIN CORRESPONDING TO EXTERIOR MEASUREMENTS ILLUSTRATED IN FIGS. A-1 AND A-2.

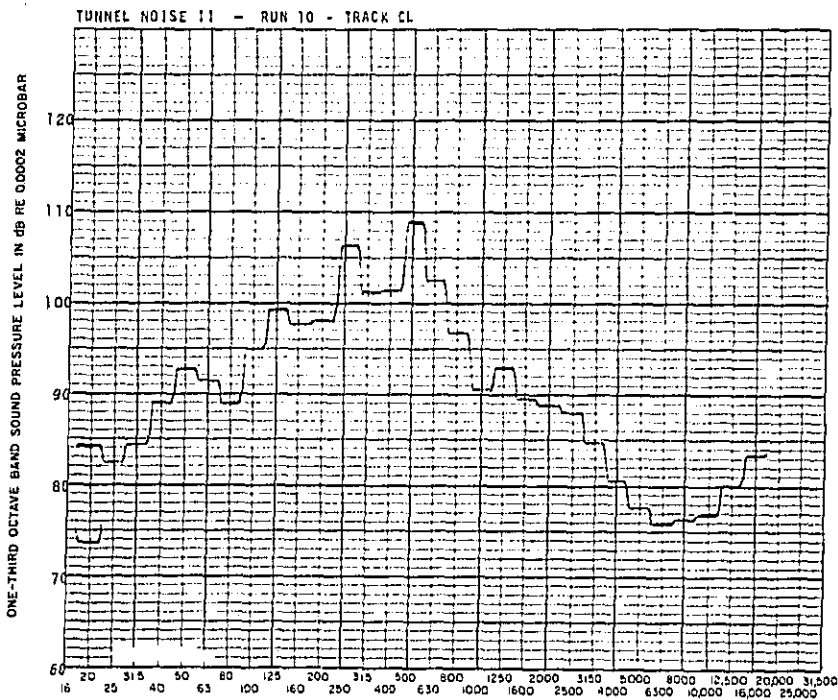
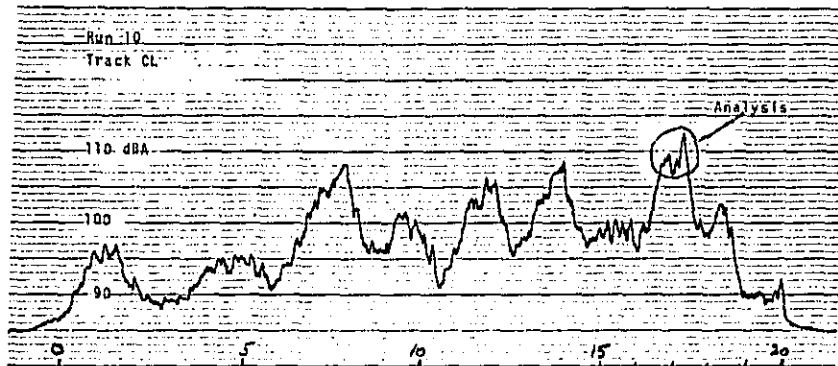

FIG. A-4. TIME HISTORY AND ONE-THIRD OCTAVE BAND SPECTRA OF NOISE MEASURED BETWEEN THE RAILS FOR A TRAIN TRAVELING IN A CUT AT 35 MPH.

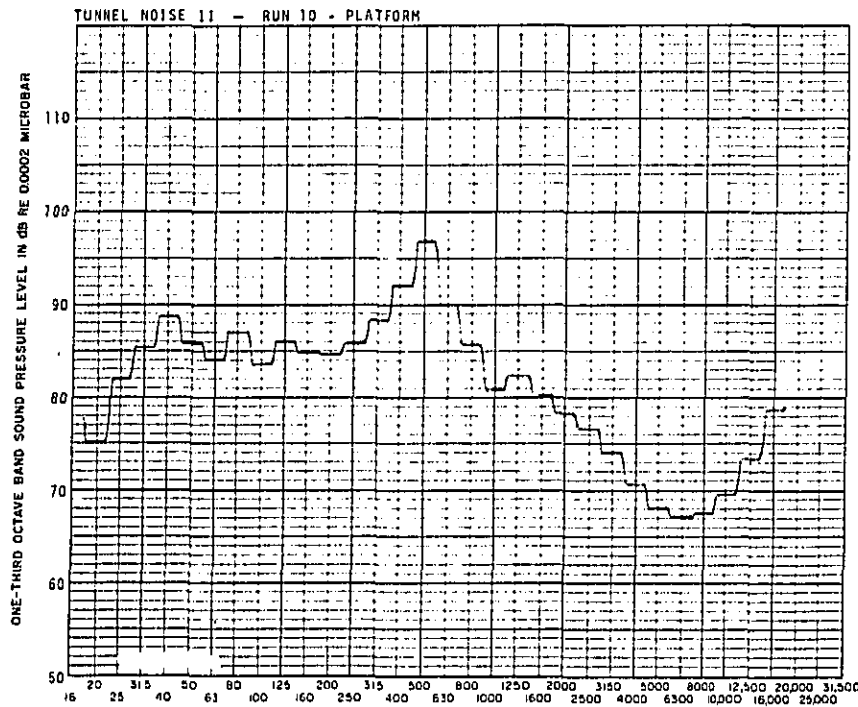
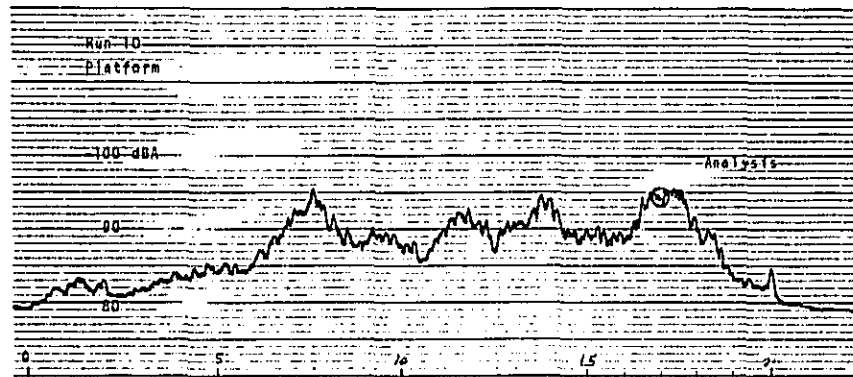

FIG. A-5. TIME HISTORY AND ONE-THIRD OCTAVE BAND SPECTRA MEASURED ON A CATWALK FOR A TRAIN TRAVELING IN A CUT AT 35 MPH.

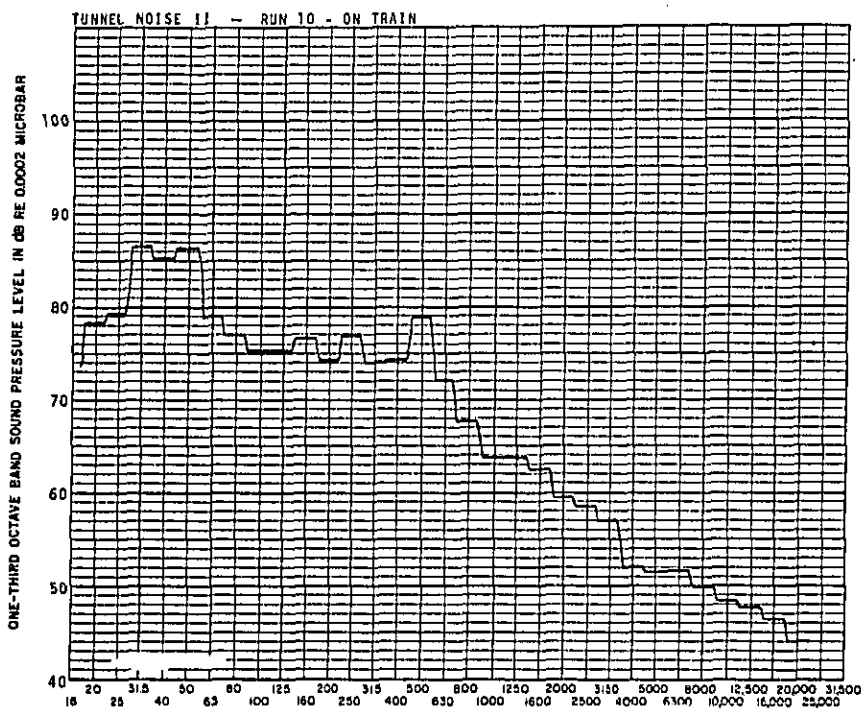

FIG. A-6. ONE-THIRD OCTAVE BAND SPECTRUM OF NOISE MEASURED IN THE TUNNEL CORRESPONDING TO EXTERIOR MEASUREMENTS ILLUSTRATED IN FIGS. A-4 AND A-5.

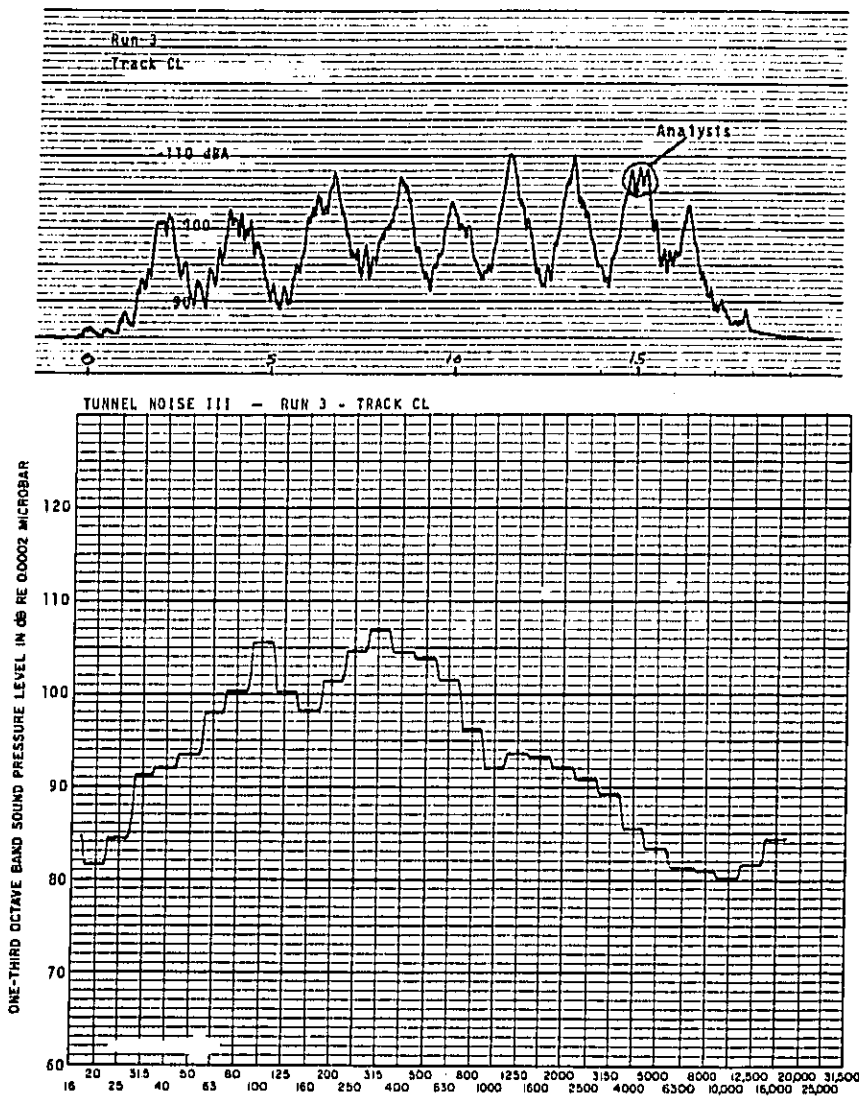

FIG. A-7. TIME HISTORY AND ONE-THIRD OCTAVE BAND SPECTRUM OF NOISE MEASURED BETWEEN THE RAILS FOR A TRAIN TRAVELING ON AN EMBANKMENT AT 35 MPH.

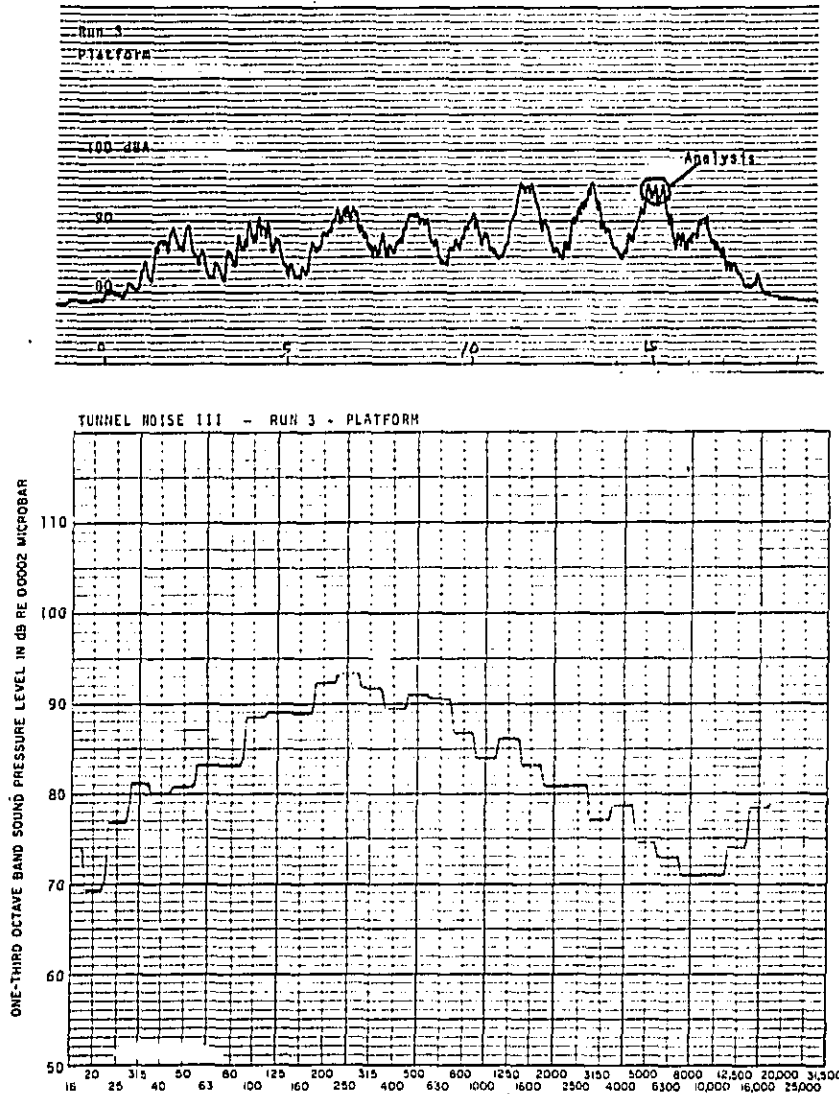

FIG. A-8. TIME HISTORY AND ONE-THIRD OCTAVE BAND SPECTRUM OF NOISE MEASURED ON A PLATFORM NEXT TO A TRAIN TRAVELING ON AN EMBANKMENT AT 35 MPH.

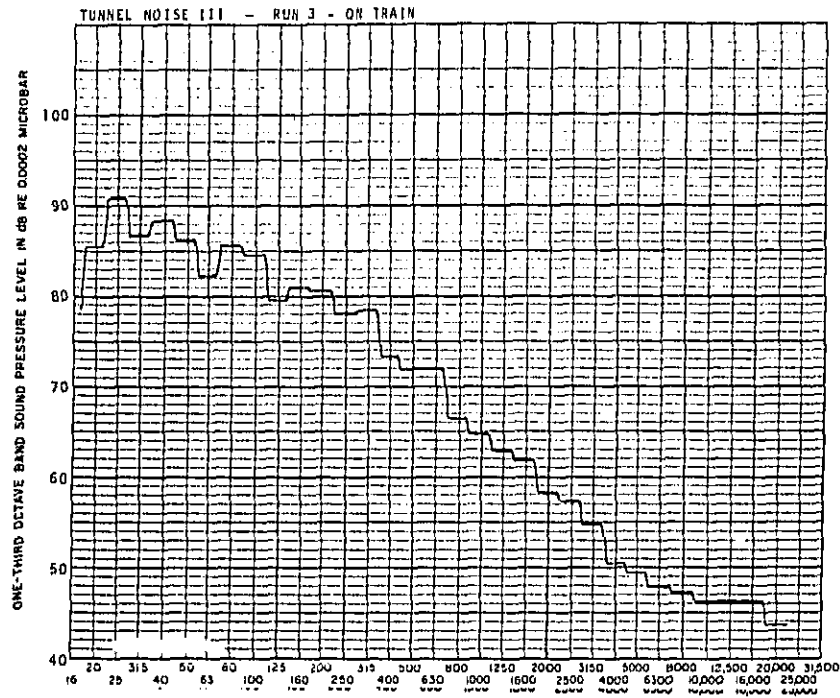

FIG. A-9. ONE-THIRD OCTAVE BAND SPECTRUM OF NOISE MEASURED IN THE TUNNEL CORRESPONDING TO EXTERIOR MEASUREMENTS ILLUSTRATED IN FIGS. A-7 AND A-8.

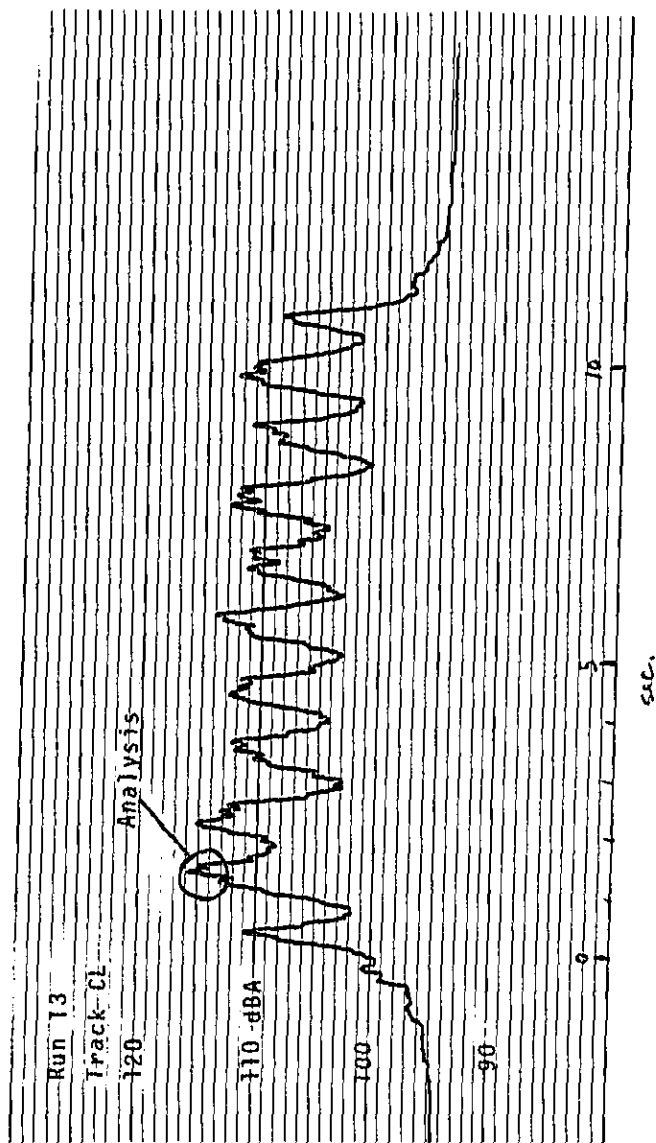

FIG. A-7. ANALYZED IN FIG. A-7.

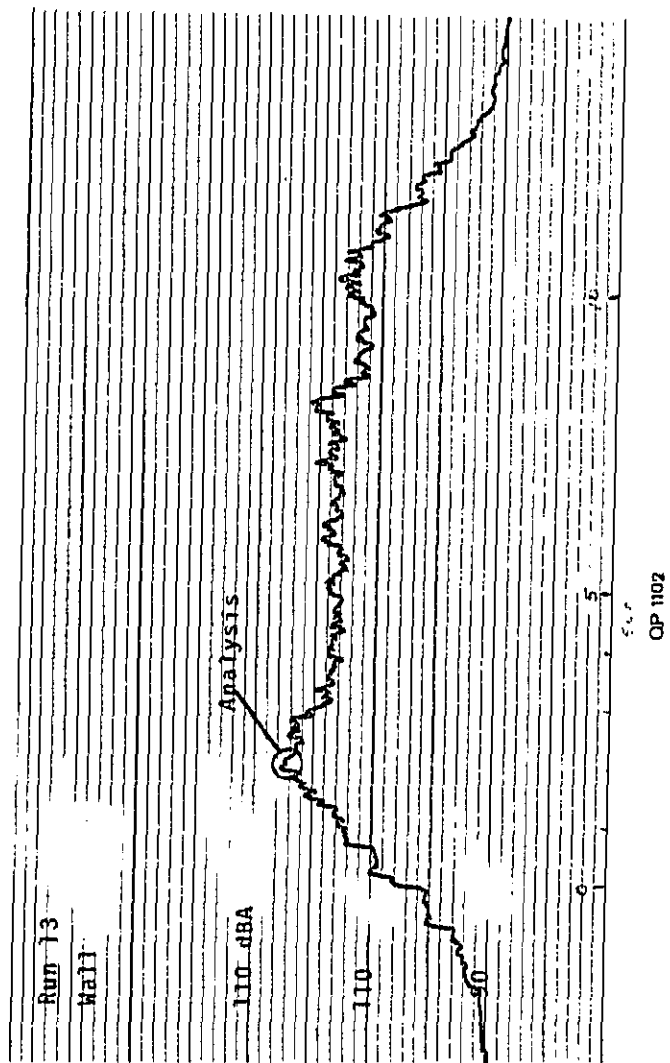

FIG. A-2. ANALYZED IN FIG. A-8.

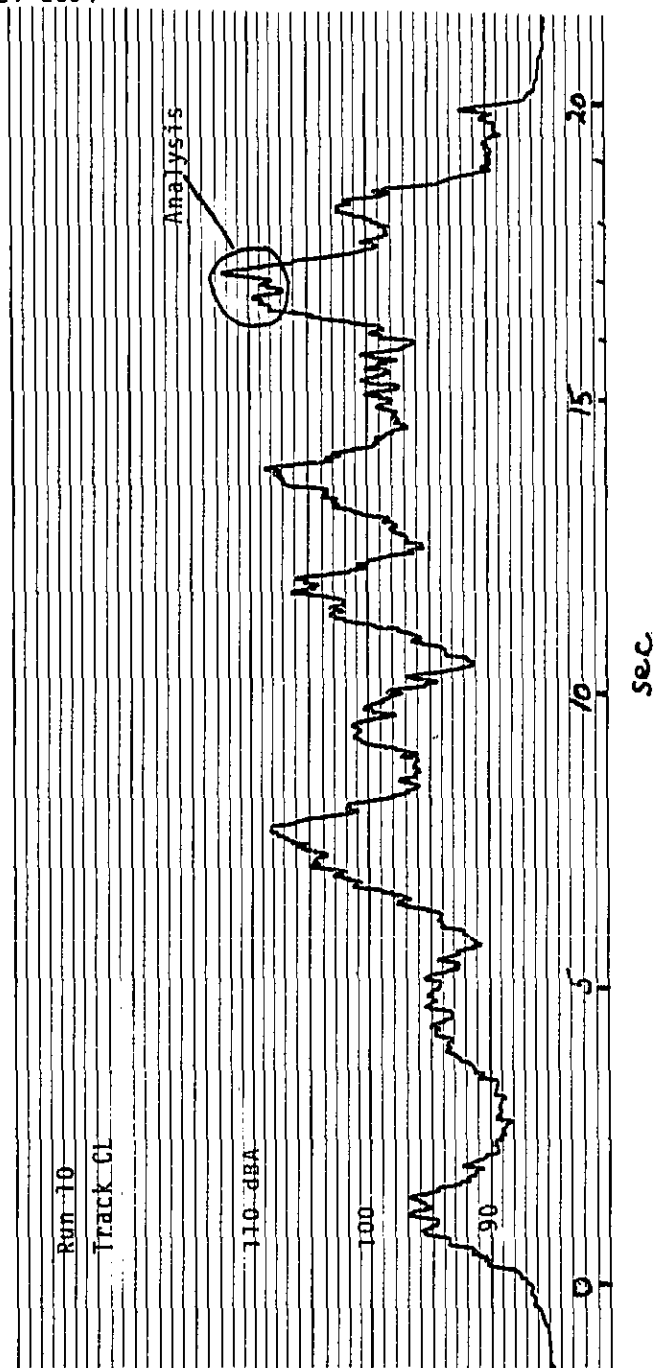
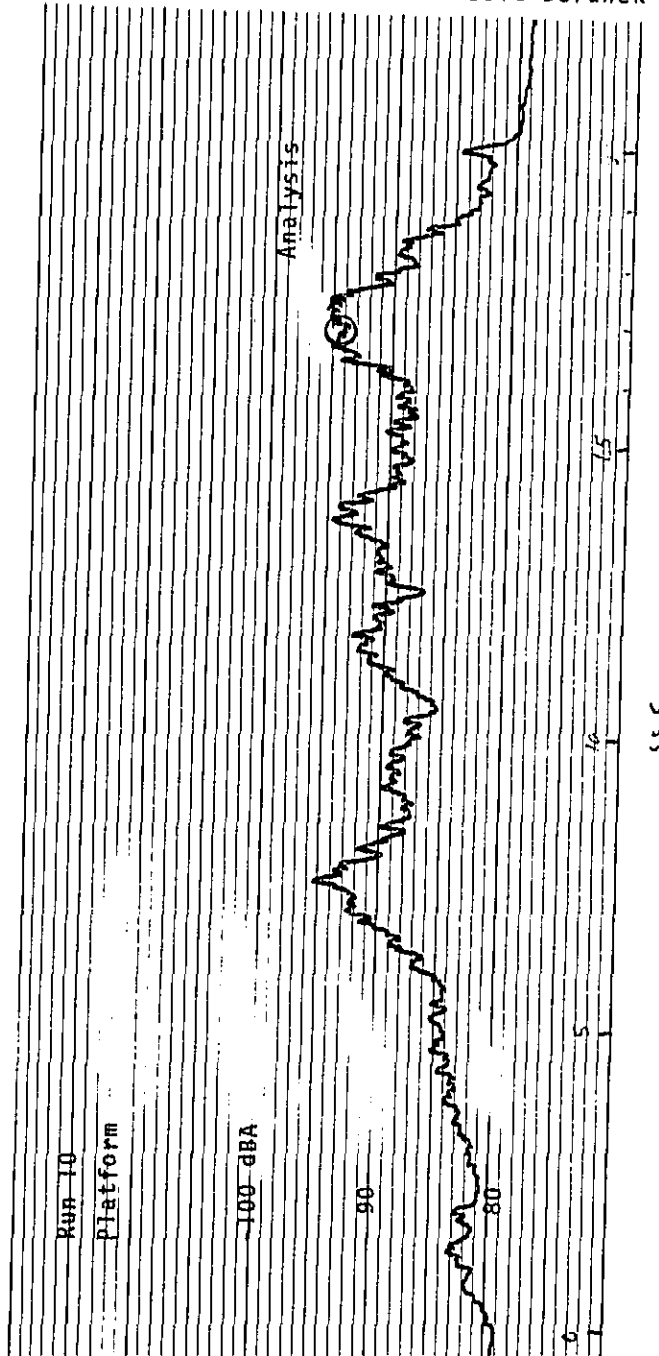

FIG. A-3. ANALYZED IN FIG. A-10.



SEC

FIG. A-4. ANALYZED IN FIG. A-11.

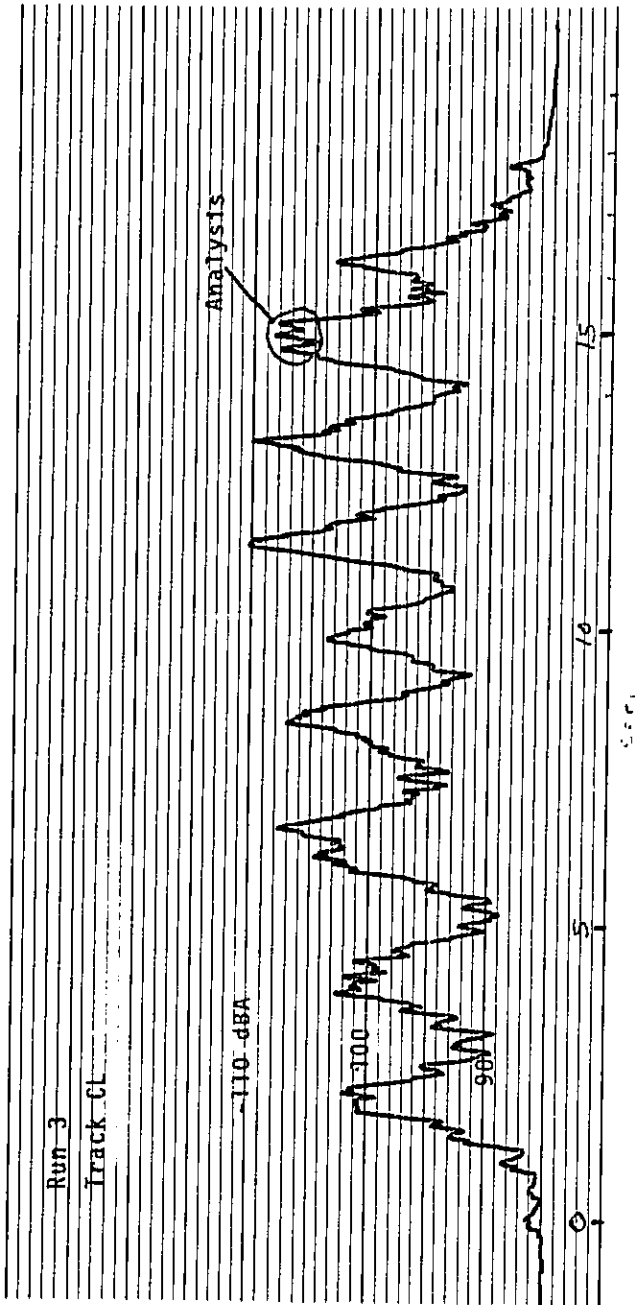

FIG. A-5. ANALYZED IN FIG. A-13.

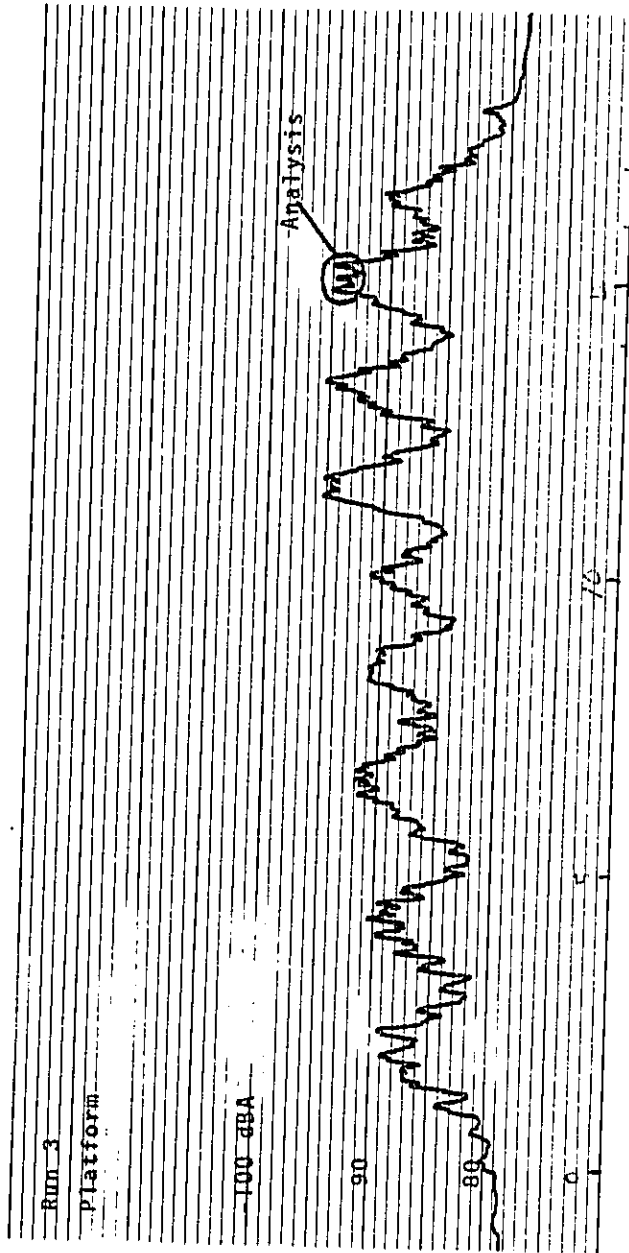

FIG. A-6. ANALYZED IN FIG. A-14.