

n-96-01  
II-A-311

ELAB report STF44 A81017

# NOISE FROM HEAVY VEHICLES

Results from stationary noise measurements

by

K. A. Abrahamsen

ELECTRONICS RESEARCH LABORATORY  
AFFILIATED WITH SINTEF



LABORATORY OF ACOUSTICS  
DEPARTMENT OF ELECTRICAL ENGINEERING

THE UNIVERSITY OF TRONDHEIM – THE NORWEGIAN INSTITUTE OF TECHNOLOGY

# ELAB

## REPORT

**SINTEF** REPORT NO  
STF44 A81017

THE ELECTRONICS RESEARCH LABORATORY - AFFILIATED WITH SINTEF  
THE UNIVERSITY OF TRONDHEIM - THE NORWEGIAN INSTITUTE OF TECHNOLOGY

DISTRIBUTION  
REPORT **Unrestricted**  
TITLE PAGE **Unrestricted**

POSTAL ADR.  
ELAB, O. S. BRAGSTADS PL. 4  
N-7034 TRONDHEIM-NTH, NORWAY

TELEPHONE NAT. (075) 93000  
TELEPHONE INT 4775 93000  
TELEX: 55552 ELAB N

PRICE: kr. 80,-

ISBN NO. 82-595-2417-1

TITLE NOISE FROM HEAVY VEHICLES, RESULTS FROM STATIONARY NOISE MEASURE- MENTS.	DATE February 1981
	NO. OF PAGES 110
AUTHOR(S) K.A. Abrahamsen	PROJECT SUPERVISOR (NTH) A. Krokstad sign.
DIVISION Acoustics Laboratory/ELAB	PROJECT NO 441113.01

PROJECT CLIENT/SPONSOR Vegdirektoratet	CLIENT'S REF
---	--------------

ABSTRACT

Stationary noise measurements have been carried out on 12 of the most sold trucks in Norway. The results are discussed with reference to the influence of the various vehicle designs on the noise emitted from the major noise sources and on cabin noise. The state of the art of noise control on typical production vehicles has been assessed and a forecast of possible further noise reduction in the near future made.

INDEXING TERMS

TUNGE KJØRETØY / HEAVY VEHICLES
STØYKILDER / NOISE SOURCES
STØYREDUKSJON / NOISE CONTROL

AUTHORIZED SIGNATURE ELAB

J. Trampe Broch  
sign.

Acknowledgements:

It is gratefully acknowledged that this investigation was made possible through financial support from the Norwegian Public Roads Administration, Road Traffic Section.

I would also like to thank all the companies which kindly lent us vehicles for the measurements, and I. Carlsen who helped with measurements and analysis.

Sammendrag:

Stående støymålinger samt måling av rullestøy og motorvibrasjoner er utført på 12 nye lastebilchassiser. 7 med motorytelse i området 235-283 kW og med 5 med motorytelse mellom 90 og 124 kW.

Målingene ble utført nær motor, vifte, avgass, luftinntak, i førerhus og i en referanseposisjon.

Resultatene er brukt som grunnlag for kilderangering og sammenligning av de forskjellige kjøretøyene. Videre er det foretatt en vurdering av hvor langt produsentene har kommet i å introdusere støysvake løsninger i sine serieproduserte kjøretøy.

De forskjellige kildemekanismene er gjennomgått og en evaluering av muligheter for støyreduksjon i den nærmeste fremtid er foretatt.

De viktigste konklusjoner som kan trekkes fra resultatene er:

Målemetoden:

- Nærfeltsmålinger egner seg for rask kilderangering og sammenligning av en serie med kjøretøy. Metodens største usikkerhet er at en lett kan få bidrag fra flere kilder i et målepunkt og dermed overestimere totalnivået noe. Mer nøyaktige metoder finnes, men disse er langt mer tid- og kostnadskrevende.
- Måling av avgass-støy bør utføres med en skjerm som hindrer motorstøy i å nå mikrofonen. Skjermen bør ha et lag med absorberende på hver side slik at refleksjoner begrenses.

Støykildene:

- Stråling fra motorblokken var den viktigste støykilden for 9 av kjøretøyene, avgass og viftestøy er også viktig i mange tilfeller, mens støy fra luftinntaket var mindre viktig.
- Rullestøy er uvesentlig under 50 km/t, men øker med hastig-

heten og resultatene antyder at rullestøy kan bli dominerende ved høye hastigheter dersom motorstøyen dempes litt fra dagens nivå.

- Motorstøyen bestemmes først og fremst av matning, forbrenning, motorblokkens dynamiske egenskaper og balanse. Gjennomgående var det gjort mindre for støymessig optimalisering av de mindre motorene. Disse har derfor større støyreduksjon potensialer enn de store motorene.
- Kraftig reduksjon av motorstøyen krever innkapsling. Det finnes idag akseptable løsninger for kjøling og vedlikehold i forbindelse med innkapsling.
- Avgass-støyen bestemmes hovedsakelig av konstruksjonen av avgassanlegget. Stor forskjell i avgass-støynivået fra de forskjellige kjøretøyene vitner om at enkelte anlegg var mindre bra utformet.
- Med dagens teknikk kan avgass-støyen elimineres relativt billig.
- Inntaksstøyen representerer ikke noe stort problem, og kan lett elimineres fullstendig med kjent teknikk.
- Viftestøy kan reduseres ved bruk av mer effektive, langsomt-roterende vifter og bruk av ujevn avstand mellom bladene.

#### Støy i førerhus:

- Støyen i førerhusene var langt under faregrensen for hørsel-skade.
- På grunn av forskjellig bruk av isolasjon og absorpsjonsmaterieell var forskjellen mellom det mest og minst støyende førerhuset 10 dB(A).
- Støyen i førerhusene var sterkt lavfrekvent på grunn av

stråling fra motoren. Lavfrekvent støy kan virke trettende på sjåførene.

- Den lavfrekvente støyen kan vanskelig dempes med isolasjon eller absorpsjon. Den har tonekarakter med grunnfrekvens lik motorens tenningsfrekvens og kan derfor muligens dempes med aktiv støykanselering

#### Fremtidig støynivå:

- Ved mer bevisst utnyttelse av dagens konstruksjonsprinsipper med tanke på støyreduksjon, kan nivået senkes 3 til 5 dB(A) for en gjennomsnittlig lastebil. Dette tilsvarer et støynivå på 83-85 dB(A) ved en akselerasjonstest etter ISO IS362.
- Ved bruk av mer avanserte støykontroll-prinsipper er det nå mulig å senke nivået under 80 dB(A). Med dagens teknikk vil dette øke kjøretøyenes produksjonskostnad med ca 10%. Fremtidig støyreduksjon ned til 80 dB(A) er avhengig av lovgivning og økonomi. Kostnadene for forbruker kan reduseres ved fritak av avgifter for meromkostningene av en støyreduksjon.
- Tiden som må til før strengere støyemisjons-regler kan innføres er avhengig av den tid produsentene trenger for å gjøre de nødvendige konstruksjons- og produksjonsforandringer. Ubesluttsomhet fra myndighetenes side i presentasjon av fremtidige krav vil føre til en langsom utvikling mot mindre støyende kjøretøyer.

<u>CONTENTS</u>	Side
ACKNOWLEDGEMENTS .....	II
SAMMENDRAG .....	III
1. CONCLUSIONS .....	1
2. INTRODUCTION .....	4
3. MEASUREMENTS .....	5
3.1. Near Field Measurements .....	6
3.2. Rolling Noise .....	12
3.3. Engine Vibrations .....	12
3.4. Accuracy .....	13
3.5. Test Sites .....	15
3.6. Analysis .....	15
4. THE VEHICLES .....	16
4.1. Light Trucks .....	16
4.2. Heavy Trucks .....	19
5. NOISE SOURCES .....	22
5.1. Structural Radiation from Diesel Engines ...	22
5.2. Exhaust Noise .....	23
5.3. Air Intake Noise .....	24
5.4. Fan Noise .....	24
5.5. Transmission Noise .....	25
5.6. Rolling Noise .....	25
6. RESULTS AND COMMENTS .....	26
7. COMPARISON AND DISCUSSION OF THE RESULTS .....	63
7.1. Engine Noise .....	63
7.2. Exhaust Noise .....	68
7.3. Air Intake Noise .....	70
7.4. Radiator Noise .....	73
7.5. Reference Position .....	75

	Side
7.6. Rolling Noise .....	80
7.7. Cabin Noise .....	82
8. NOISE REDUCTION .....	88
8.1. Possible Noise Reduction with Present Technology .....	88
8.2. Further Noise Reduction .....	92
8.3. Noise Emission Forecast .....	94
REFERENCES .....	96
APPENDIX I	
APPENDIX II	



1. CONCLUSIONS

Stationary noise measurements have been carried out on 12 of the most sold trucks in Norway. The results are discussed with reference to the influence of the various vehicle designs on the noise emitted from the major noise sourcer and on cabin noise. The state of the art of noise control on typical production vehicles has been assessed and a forecast of possible further noise reduction in the near future made.

Several conclusions can be drawn from the work described in this report:

Measurement Procedures:

- A stationary truck can at a distance greater than 2 m be regarded as a point source with hemispherical radiation.
  
- Near field measurement is a method for rapid source ranking and comparison for a series of vehicles. Due to unknown contamination from neighbouring sources, the method has some uncertainty and the overall level is easily overestimated, more accurate methods are available, but they are more time consuming and expensive.
  
- Near field exhaust noise measurements on trucks ought to be carried out with a barrier to shield the microphone from engine noise, as considerable contamination might otherwise occur. The barrier should have absorption material on each side to reduce reflections.

Noise Sources:

- Radiation from the engine block is the major noise source for all but three of the vehicles. Exhaust and fan noise is also important, whilst intake noise is insignificant for most of the vehicles.
  
- Rolling noise is insignificant for vehicle speeds below 50

km/h, but becomes increasingly significant at higher speeds and the results imply that rolling noise will dominate at high vehicle speeds if the power unit noise sources are slightly attenuated.

- Engine noise depends mainly upon induction, combustion, balance and structural stiffness. The light trucks had the least advanced designs in such respects and thus have the largest engine noise reduction potentials.
- Further reduction of engine noise require enclosures around engine and gearbox. Methods of doing this without unacceptable interference with cooling and maintenance are known today.
- Exhaust noise emission is mainly determined by the exhaust system design. Large variations in the results indicated that several vehicles had badly designed exhaust systems.
- Exhaust noise can be eliminated as a significant source at little cost. Muffler volume, element position, and muffler strength are the most important parameters, resonators, Y connectors, balance tubes, T splitters and absorbers in the end tubes can be used for further reduction.
- Intake noise is not a serious problem and is easily eliminated by proper system design.
- Fan noise can be reduced by redesign of the fan. More efficient slower revolving fans with unequal blade spacing can solve the problem.

Cabin Noise:

- Cabin noise levels were well below the danger level for hearing damage.
- The difference between the least and most noisy cabin was 10 dB(A), due to varying use of sound insulation and absorption materials.

- The noise in all cabins had a strong low frequent contribution from the engines, which may be tiring or annoying.
- The low frequent noise is harmonic, following the engine firing frequency. Active noise cancellation may be a remedy.

Future Noise Emission:

- With present design principles the noise level for an average truck could be reduced 3 to 5 dB(A) with little effort from the manufacturers, giving an ISO IS 362 drive part noise level of 83-85 dB(A).
- Techniques to reduce the drive past noise level for a production truck below 80 dB(A) are known. It is estimated that the production cost of the vehicle would increase with up to 10% if these techniques were implemented on production vehicles today. The degree of noise reduction down to 80 dB(A) depends upon legislation and economical aspects. The cost can be reduced by taxation benefits.
- The time lapse needed before stricter legislation can be introduced depends upon the time required for design and production line changes. However, indecisiveness by the legislating authorities could delay the process.

2. INTRODUCTION

The aims of this project were to identify and rank the most important noise sources on a selection of the most-sold trucks in Norway. The influence of different technical solutions on noise emission could then be discussed for each source. In this way it was possible to assess the state of the art of noise control on trucks sold today and consider possible noise reduction by combining the best solutions in one truck.

Such knowledge is essential when discussing future emission limits for trucks. In the literature much information is available on possible noise control methods for trucks. However, little is known about how much of this different manufactures have applied to their production vehicles.

### 3. MEASUREMENTS

Noise measurements were made near the major noise sources, at a reference position, and in the cabin. Rolling noise was measured with the engine shut down. Engine vibration was measured at several positions with the engine at maximum speed.

All the noise measurements, apart from those of rolling noise, were carried out for varying engine speed on stationary vehicles. Although such data do not yield any clear information of the vehicles potential noise in traffic or during drive past tests such as laid down in \*ISO IS 362, they serve as a basis for comparison of different designs. A previous investigation [1] demonstrated that stationary noise measurements on vehicles may give valuable information, in addition to information from drive part tests. Advantages of stationary tests, are that measurements can be carried out close to the major noise sources, that identical measurement conditions can easily be established and that reasonably limited measurement sites can be used. The effects of load and acceleration have been described in the literature [2 and 3]. Engine speed is the most important single parameter determining noise from a given size of diesel powered vehicle. Engine load can be more or less important and in previous tests [2], the noise level has been found to increase from 0-10 dB(A) when full load is applied. This is partially due to advanced injection timing and partially due to increased fuelling, both which increase the rate of pressure rise in the cylinders of the engine. Acceleration has been found to increase the noise emission by typically 3 dB(A) from full load at steady speed [3]. It is suggested that this is due to temperature variations in the engine during acceleration.

---

\* International Organization for Standardization.

### 3.1. Near Field Measurements.

Several methods can be used for vehicle noise source identification and ranking. Crocker and Sullivan [4] have presented a review of different methods.

For the purpose of this project a reasonably quick method had to be used, since measurements were to be carried out on a series of vehicles. Near field measurements were therefore chosen.

In this approach microphones are placed close to individual noise sources on a vehicle. It is assumed that if a microphone is placed very near to a source, most of the sound pressure sensed by the microphone is caused by that source and very little is caused by other sources. This is of course only true close to strong sources when other sources nearby are considerably weaker. Another drawback of the method is that a single microphone does not sense source directivity, and one either has to assume all sources to be simple point sources or use a number of microphones around each source. Finally, in the acoustic near field particle velocity and pressure are not in phase for low frequencies, and the field does not completely propagate.

To test the validity of the method and to locate the best positions for measurement, the sound field around a Volvo F609 truck was investigated. The A-weighted sound pressure levels at a distance of 0 to 2 m from the vehicle were registered with a sound level meter and plotted. (See figure 1) This was done at a height of 0,5 m for idle and maximum engine speed and at a height of 1,5 m for maximum engine speed.

The results shown in figure (2) reveal that the highest sound pressure levels were outside the wheel arches, in front of the radiator, near the air intake and at the exhaust.



Figure 1. Mapping of the Sound Level Distribution  
Around a Volvo F609.

It is also clear that if the vehicle is viewed from a distance greater than 2 m, the source centre for the complete vehicle can be found approximately at the centre of the engine and that the complete vehicle can be regarded as a point source with hemispherical radiation.

For the complete series of vehicles it was decided to place microphones in the following positions:

1. Between the top of the wheel and the wheel arch, 10 cm from vehicle side. At this position the highest level of engine noise can be registered, as the engine on most vehicles is unshielded by the body here, and because some reverberant build up may occur in the wheel arch.
2. In front of the midpoint of the radiator, 10 cm from the vehicle front.  
At this position fan noise and forward radiating engine noise will be registered. Whether the fan or the engine will dominate depend upon the particular design.
3. 20 cm from the air intake to register intake noise.  
The position of the intake varies from vehicle to vehicle,

FIGURE 2. SOUND LEVEL DISTRIBUTION dB(A)  
AROUND VOLVO F609

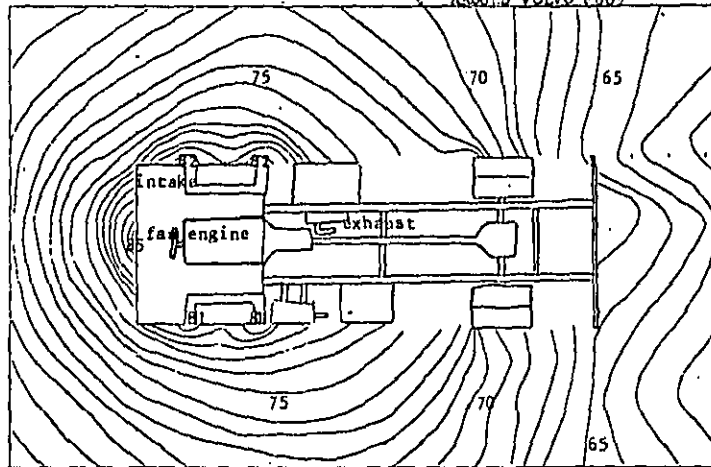

HEIGHT 0.5 m ENGINE SPEED: IDLE

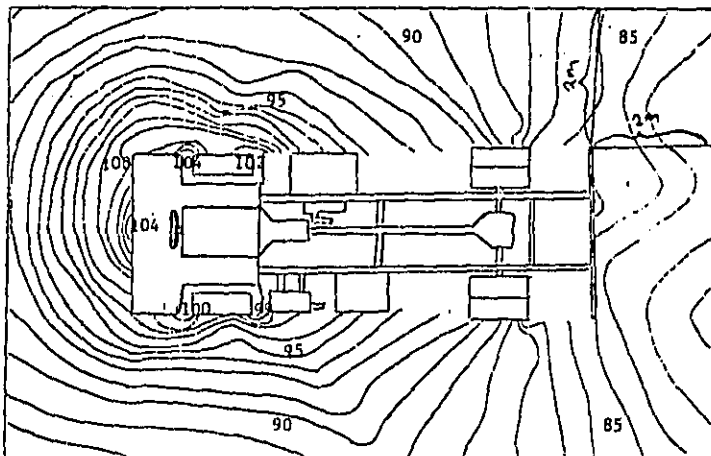

HEIGHT 0.5 m ENGINE SPEED: 2800 RPM

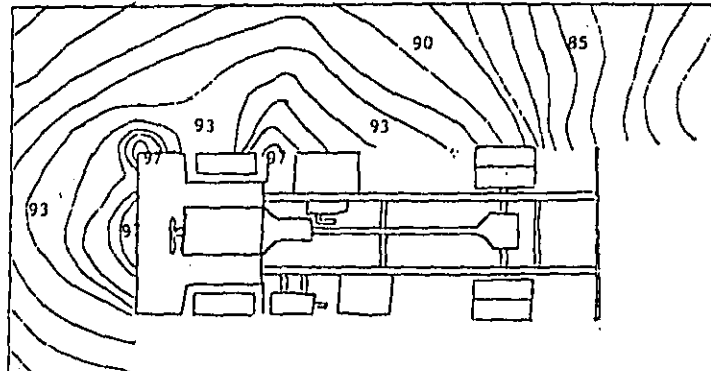

HEIGHT 1.5 m ENGINE SPEED: 2800 RPM



and in some cases when the intake is inside the engine compartment, measurement at this position is not feasible. Also, as the intake is a fairly weak source, contamination from other sources may occur when the intake is situated on the vehicle front.

4. Near the exhaust as described in ISO/DIS 5130, i.e. 50 cm from the outlet at an angle of  $45^{\circ}$  to the flow. As the engine often is visible from the exhaust outlet on vehicles of this type, it was decided to place a barrier between the exhaust and the engine to shield the microphone from engine noise. The barrier consisted of one layer (5 cm) of heavy mineralwool with 10 cm absorbtive mats on each side, figure (3).

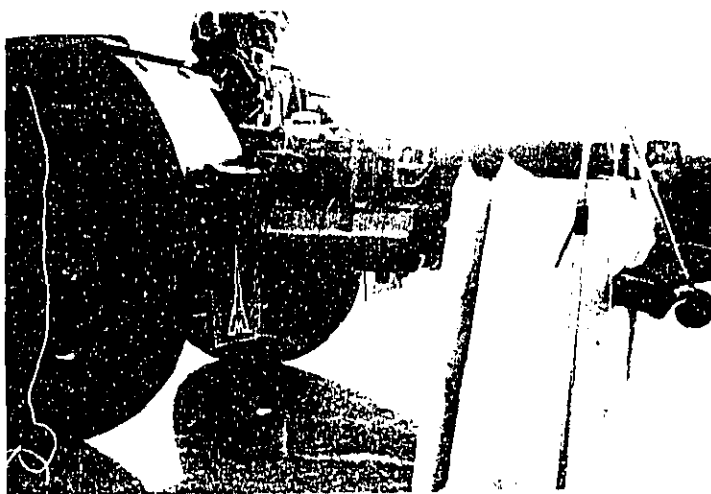

Figure 3. Barrier in Position for Recording.

Measurements were made on the Volvo F609 with and without the barrier to check it's influence. In the reference position 15 m from the vehicle and for position 1, 2 and 3 no noticeable effect could be observed.

In the position near the exhaust the level dropped 2 dB(A) at maximum engine speed and 3 dB(A) at idle when the barrier was introduced. This indicates considerable

contamination from the engine in this position.

5. In a reference position 15 m perpendicularly from the side of the vehicle at the midpoint between the front and the exhaust outlet. During the initial tests with the Volvo F609, 4 reference positions were tried. These are indicated in figure (4) below.

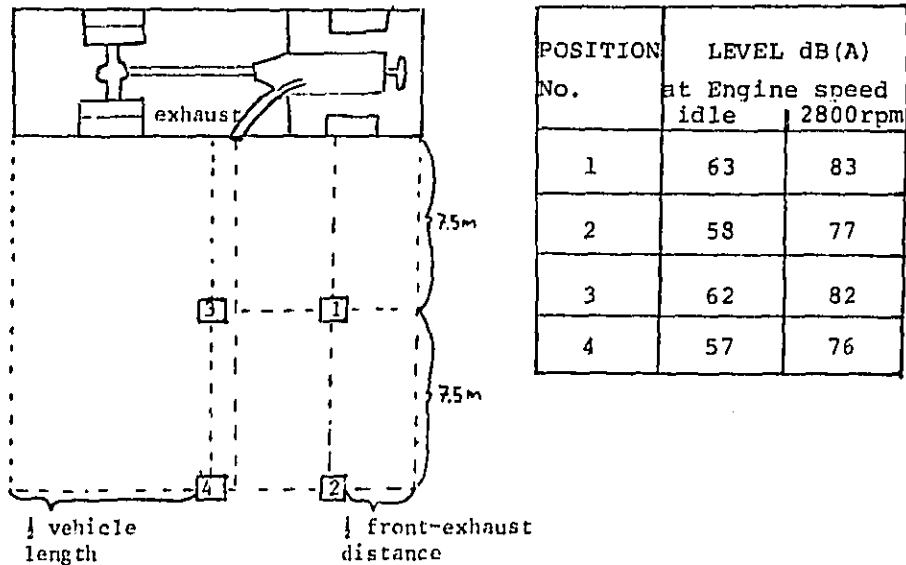

Figure 4. Reference Position during Initial Tests on Volvo F609.

The levels were slightly higher when the reference position was at the midpoint between the front of the vehicle and the exhaust outlet, than when it was at the midpoint of the vehicle length. This is due to the source center being at the front of the vehicle front.

The reason for the slight underestimate of the inverse square law for the idling engine, is probably because the low frequency content of the noise is more dominating at

low than high engine speeds. Hence, since the acoustic near field extends further for low than for high frequencies one gets a slight overestimate of the level at 7,5 m.

6. In the cabin corresponding to microphone position B for the driver's seat as specified in ISO/DIS 5128, see figure (5) below.

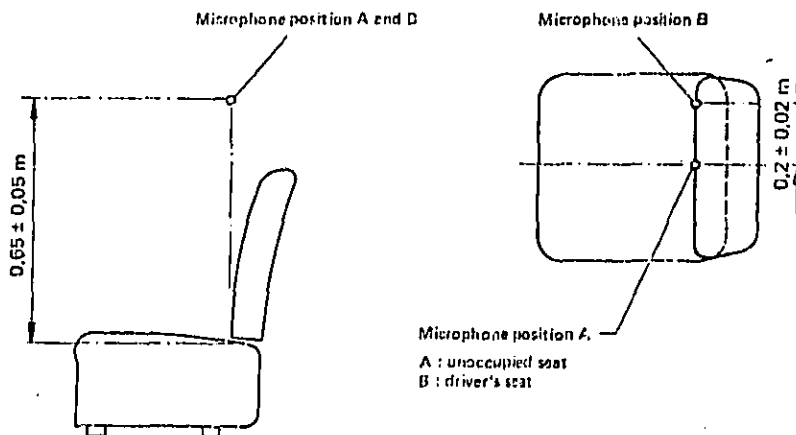

Figure 5. Microphone Position for Cabin Noise Measurement.

The levels in this position are used to evaluate the acoustic quality of the cabins.

Recordings were taken for slowly increasing engine speed (2000 RPM/min) from idle to the engine speed for maximum rated power and then slowly decreasing to idle again. The engine speed was recorded simultaneously with the noise and used as a reference when the levels were plotted. Recordings were also taken for three constant engine speeds: idle, speed for maximum rated power, and a speed equal to the arithmetic middle of these, denoted S/2.

Experimental layout and a list of the instruments used can be found in appendix I.

### 3.2. Rolling Noise.

Noise was measured with the vehicle rolling on a smooth asphalted road with the engine shut down. Measurements were made with a Sound Level meter and plotter 7,5 m from the centre line of the vehicle path, for speeds of 50 km/h and 70 km/h, see figure (6). 7,5 m was chosen as a reference distance, because it was difficult to find roads surrounded by hard surfaces of larger size.

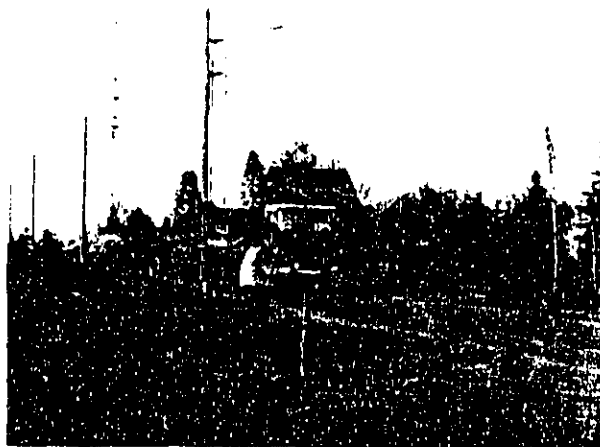

Figure 6. Measurement of Rolling Noise.

### 3.3. Engine Vibrations.

In a previous investigation [1] of passenger cars, vibration was measured at specified positions on the engines. During the initial trial measurements on the Volvo F609, it was found that the vibration levels on the engine varied significantly from position to position. This is probably due to the structural modeshapes of the engines having nodes and antinodes.

It was therefore decided to measure vibration levels at many different positions on the engines with a hand held probe, to

get an overview of the vibration levels on each engine, figure (7). The experimental apparatus is shown in appendix I.

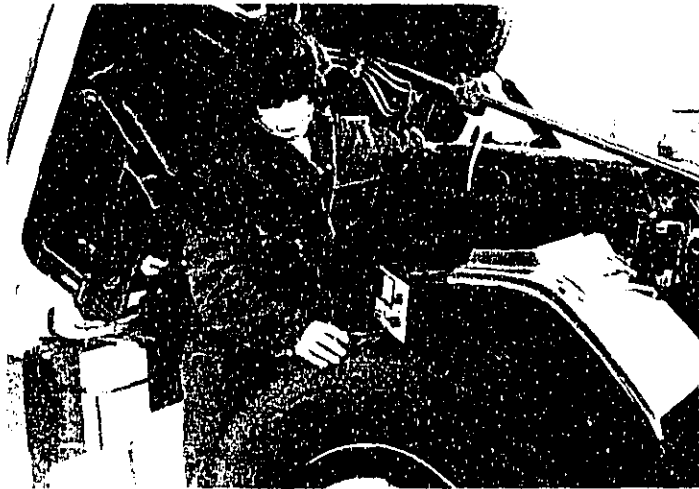

Figure 7. Measurement of Engine Vibration.

#### 3.4. Accuracy.

The accuracy of the results is primarily dependent on:

- Differences in specified and attained running conditions of the engines.
- Positioning of microphones.
- Background noise level.
- The accuracy of the acoustic measuring equipment.
- Metrological conditions.

[5] has investigated the accuracy of near field measurements on a passenger car thoroughly. Here, only the most important factors will be discussed briefly.

All the vehicles were brand new chassis, borrowed directly from the dealers, having covered only between 100 and 1000 kms. Hence they should be in good technical order with engines adjusted to the correct specifications.

The engine speed is a critical parameter which was measured with a high quality RPM meter with specified accuracy  $\pm 3\%$ . This is typically equivalent to  $\pm 1$  dB(A) for maximum engine speed in the reference position.

The operating temperature is very important for diesel engines. The ignition and combustion of the fuel/air mixture depends upon pressure and temperature. [3] illustrated that only small temperature differences, such as the change in temperature between an idling and accelerating engine, might change the noise level by up to 2 dB(A) for an engine at steady speed and up to 6 dB(A) during acceleration. It was also found that variation in intake air temperature was much more significant than change in the actual engine temperature. Hence temperature variations are more critical for naturally aspirated than for turbo charged engines. All the engines were warmed up to normal operating temperature and given a few quick accelerations immediately prior to commencement of recordings. The engine speed was varied slowly (2000 RPM/min) such that the engine operation resembled steady state more than acceleration. Hence the error due to temperature change during operation should be limited to 2 dB(A).

As seen from figure (2) an error in microphone position of 5 cm could cause an error in the near field measurements of 1 dB(A). The microphones were positioned accurately on appropriate microphone stands, hence errors were unlikely to exceed 1 dB(A).

The background noise was always at least 10 dB below the measured noise and usually much more than 10 dB below. Thus the effect of background noise can be disregarded.

The acoustic measuring equipment consisted of high quality laboratory equipment. The tape recorder being the potentially weakest link in the chain with a frequency response of  $\pm 0,5$  dB between DC and 10000 Hz.

The weather conditions during the recordings were in the range

Air temperature +4 - +16°C  
Wind speed 0 - 10 m/s  
Mainly sunny and always dry.

Only the wind speed is of importance here and according to [2], could lead to an error of + 0,3 dB.

For the rolling noise measurements vehicle speed was an additional error source. The speed was monitored on the vehicle speedometer, the accuracy of which was not checked.

### 3.5. Test Sites.

The measurements were carried out on 4 different sites in the vicinity of Oslo and Trondheim. All the sites consisted of a flat areas covered by a hard reflecting surface. There were no significant obstacles within a radius of 50 m of the vehicle on any of the sites. Background noise was generally low.

### 3.6. Analysis.

Linear and A-weighted sound pressure levels were plotted versus engine speed. When a difference between the level at increasing and decreasing engine speed occurred the average was used as the result.

Frequency analysis was carried out for the medium engine speed S/2, with a FFT analyser. 512 points auto power spectra were computed using a Hanning window and 50 stable averages.

#### 4. THE VEHICLES.

The vehicles were chosen among the most sold trucks in Norway during the last 3 years. Appendix II shows the number of trucks sold in Norway during this period.

The vehicles were all brand new and in chassis configuration. Chassis configuration was chosen since trucks may have rear bodies built up in many different ways, with unpredictable refraction and radiation characteristics.

Two different groups of trucks were tested:

- Light trucks with engine power in the range: 90-124 KW
- Heavy trucks with engine power in the range: 235-283 KW

It is natural to make a division between the more and less powerful vehicles, as there are many difference both in construction and usage.

##### 4.1. Light Trucks.

The vehicles in this group had gross vehicle weights (g.v.w.) in the range 8000 kg to 15000 kg, and are typically used in goods distribution and other light local transport. They are mainly operated by companies to cover their own transport requirements, and are often driven in urban environments most of their operational life. Hence they are subjected to much discontinuous driving and operate in noise sensitive environments. All the vehicles in this group were forward control trucks.

The technical data of the vehicles are summed up in table (1) and their engine performance depicted in figure (8).



Table 1. Technical Data for the Light Trucks.

Vehicle type	Engine* type	Engine specifications				Weights		
		Power KW	HP	Capacity (L)	Compression- ratio	Stroke/Bore- ratio	Chassis Weight	G.V.W.
Volvo F609	I6	90	120	5,48	17:1	1,22	3185	9700
Mercedes-Benz 1217	I6T	124	168	5,68	16:1	1,32	4400	13000
Fiat 79-F-13	I6	95,7	130	5,50	17:1	1,06	3120	8000
Bedford TM 1500	I6	112	152	8,20	17:1	0,89	4800	15000
Magirus Deutz 160M13FL	I6T	118	160	6,13	18:1	1,22	3860	12000

\* Engine type

- I - In line engine configuration
- 6 - Number of cylinders
- T - Turbo charged

FIGURE 8  
ENGINE PERFORMANCE FOR THE LIGHT TRUCKS

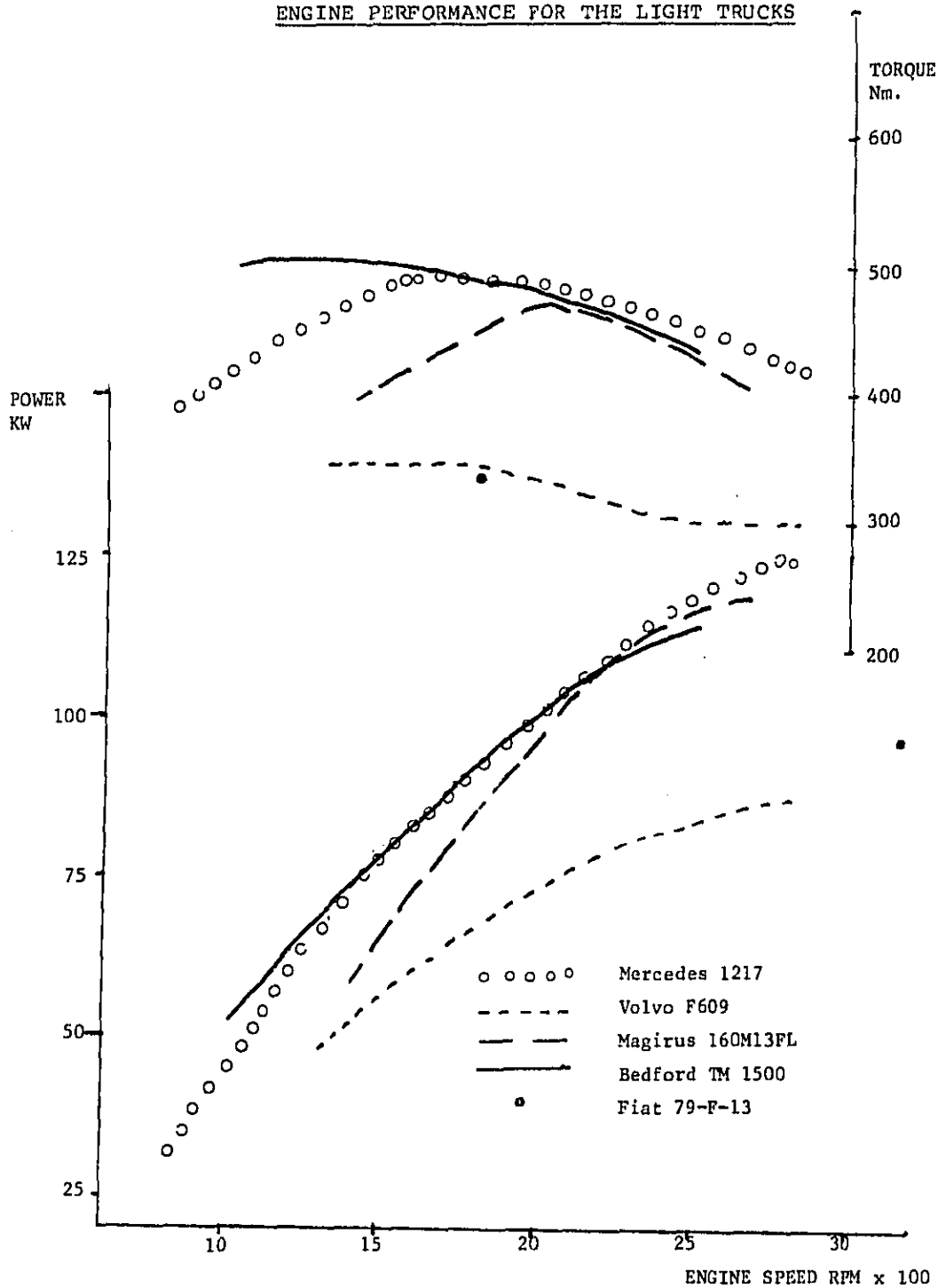

As can be seen from table (1) and figure (8), the engines had reasonably similar specifications. A more specific presentation of each vehicle is given in chapter 6.

#### 4.2. Heavy Trucks.

The vehicles in this group had g.v.w. in the range 16800 kg to 23500 kg. They are typically used for long distance haulage work or for heavy local transport, e.g. on construction sites, and are usually driven a considerable time on major highways and in sparsely populated areas. Such vehicles are usually operated by transport firms depending upon a high utilization of their trucks. Two of the vehicles in this group were normal control trucks, (Volvo N12 and Scania L141) the others had forward control.

The technical data of the vehicles are summed in table (2) and their engine performances depicted in figure (9).

All the engines were four stroke engines of the direct injection type. A more specific presentation is given in chapter 6.

Table 2. Technical Data for the Heavy Trucks.

Vehicle type	Engine* type	Engine specifications				Weights		
		Power KW	HP	Capacity (L)	Compression- ratio	Stroke/Bore- ratio	Chassis Wheight	G.V.W
Volvo N12	I6T	240	326	12,00	13,3	1,15	7600	23000
Volvo F12	I6TC	283	385	12,00	14,2	1,15	8300	23500
Mercedes-Benz 1932	V10	235	320	15,95	17,2	1,04	6700	17000
Scania L141	V8T	275	375	14,20	15	1,10	8215	23000
Ford Transcontinental 4432	I6TC	235	320	14,00	14,3	1,09	6910	17000
Magirus 320M19FL	V10	235	320	15,95	17,2	1,04	6980	16800
M.A.N. 19.321F	I6TC	235	320	11,42	17,0	1,24	6700	17500

\* Engine type

- I - In line, V - Vee - Engine configuration
- 6, 8, 10 - Number of cylinders
- T - Turbo
- C - Intercooler



## 5. NOISE SOURCES.

There are two types of noise sources on vehicles. Those whose level is determined by engine speed, referred to as power unit noise sources, and those whose level is controlled by the road speed, called rolling noise sources. At the moment, for the speeds at which trucks operate in Norway, the power unit sources are most significant.

A brief explanation of the mechanisms and the characteristics of the main power unit and rolling noise sources will be given below. Source mechanisms of engines and vehicles have been the topic for much research and complementary literature can easily be found. Reviews of source mechanisms in diesel engines and vehicles are given by [6 and 7].

### 5.1. Structural Radiation from Diesel Engines.

Diesel engines used in trucks are large units which emit considerable noise energy. The engine structure which is constructed to hold the working components in the correct relative location is excited into vibration by the numerous forces acting during the engine work cycle. The movement of the engine surfaces causes pressure perturbations in the surrounding air and some of these pressure fluctuations are transmitted through the air as sound.

The forces acting in the engine are pressure forces due to combustion, inertia forces due to unbalance of moving parts, and impulsive forces due to clearances and backlash in the machinery.

The pressure and inertia forces are cyclic and are the reasons for the significant low frequency noise radiated by the engines. In multicylinder diesel engines the pressure forces are more important than the inertia forces.

The impulsive forces cause vibrational energy to go into the modes of the engine structure. Hence free vibration occur over a wide frequency range. The energy in these impulses are determined by the rise time and maximum force of the impact which again mainly is controlled by the rate of pressure rise during combustion. The magnitude of the free vibrations in the structure is also dependent upon the dynamic response of the structure, which is determined by the mass, stiffness and damping.

Because these properties vary throughout the structure and the forces of excitation act at different positions, noise radiation from the engine will vary over its surface.

Not all pressure fluctuations are transmitted away from the structure equally well. In some cases cancellation and reactive effects will occur. These effects depends upon the physical engine size, wall thickness and material and are only significant at low frequencies for most diesel engine structures.

### 5.2. Exhaust Noise.

The exhaust noise consists of low frequency pulses and some broadband jet noise of higher frequency. The pulses are produced by the sudden release of high pressure gas from the engine when the exhaust outlet opens, while the broad band noise stems from the high velocity gas flow from the cylinders during the exhaust stroke. Most of the energy in the pressure fluctuations is attenuated in the exhaust system, which usually has low pass filter characteristics. Hence the first few harmonics in the pulse noise will usually be transmitted to the ambient air relatively unattenuated, and the exhaust noise will have a low frequent character. However, sometimes regeneration of jet noise may occur in the final part of the exhaust system and alter this.

### 5.3. Air Intake Noise.

Air intake noise is in many ways similar to exhaust noise. It is generated by the pressure drop everytime the engine draws in air and by the flow of air through the intake. The magnitudes of these pressure pulses are considerably smaller than the magnitudes of the exhaust pulses and the flow is less due to a smaller gass volume being drawn in than emitted from the engine. Still, air intake noise may be of importance if it is not attenuated sufficiently. Exhaust and air intake noise is more load dependent than other sources. In turbocharged engines the blades of the turbocharger may generate a high frequency tone.

### 5.4. Fan Noise.

Trucks require cooling systems with forced air flow to provide heat rejection at maximum engine power with no or little ram air cooling. This is usually provided by an axial fan, typically 0,35 m to 0,7 m in diameter with between 4 and 10 blades.

The fan blades on an axial fan are usually slightly curved to give tem aerofoil characteristics and have a set pitch angle to the plane of rotation. As the fan rotates unequal pressures are generated on each side of the blade, and air drawn through the fan by this pressure difference.

Since the pitch angle is fixed, the angle of attack of the aerofoil will vary with vehicle speed and the fan will be more or less efficient at different speeds. This together with the degree of turbulence of the incoming flow will cause vortices to build up over the fan blades and the flow from the fan will be more or less turbulent and thus emit broad band noise. At the ends of the blades the pressure difference will cause air to leak from one side to the other and this will also generate vortices and broad band noise.



If the fan blades are equally spaced around the hub, significant discrete tones will be produced. Because every time a blade passes through a given point the air at that point receives an impulse, and a tone called blade passage frequency is generated. The frequency of this tone is given by:

$$f_B = n \times N$$

where:  $f_B$  - blade passage frequency, (Hz)  
n - fan speed, (revolutions per second)  
N - number of fan blades

This tone may vary from 60 to 425 Hz for diesel engines and may with it's higher harmonics cause annoyance. The effect may be avoided by unequal spacing of the blades around the hub.

#### 5.5. Transmission Noise.

Impacts between gears create discrete noise at a frequency equal to the number of gear teeth times the speed of rotation of the gear wheel. Gear noise as such is usually unimportant, but structural radiation may be significant from clutch cover/gearbox casing. The mechanism of this noise source is the same as for structural radiation from the engine.

#### 5.6. Rolling Noise.

Rolling noise has it's main contribution from the tyres, although some structural radiation may come from the vehicle body and at higher speeds aerodynamic turbulence noise from the body may be noticeable.

Tyre noise has several generation mechanisms. Some noise is generated due to impacts of the elements of the treads with elements of road surface, some is due to deflection of the tyre as it rolls and some is created by the suction made by pockets in the tread.

6. RESULTS AND COMMENTS.

In this section results are presented numerically for each vehicle, together with spectra of the noise at each microphone position, at the engine speed S/2.

The differences between A-weighted and linear levels were considerable for some microphone positions, and both levels are presented for these positions. All the spectra display A-weighted levels.

Radiator noise is the noise registered at microphone position 2 in front of the radiator, and hence consists of fan noise and forward radiated engine noise.

The vibration levels were registered normally to the engine surface below the position they are printed, unless arrows indicate other directions.

The light trucks are presented first followed by the heavy ones. In each group the vehicles are presented in alphabetical order.

Note that the results presented here are measured at different distances from their sources (see chapter 3). Corrections for distance must therefore be made before the results from the sources on one vehicle can be compared individually.

BEDFORD TM 1500



This is the heaviest vehicle of the "Light Trucks" in this investigation, and the smallest model in the Bedford TM series. It has a Bedford 500 engine which was used extensively in the old TK series. The engine has a large volume for it's power output and is the only oversquare engine in this investigation. Air intake noise could not be measured because the intake was positioned close to the engine side.

IDLE = 700 RPM, S/2 = 1600 RPM,  
MAX = 2500 RPM

RESULTS

ENGINE SPEED	A-weighted sound pressure level dB(A)			Linear sound pressure level dB		
	IDLE	S/2	MAX.	IDLE	S/2	MAX.
REFERENCE POSITION (15 m)	59	67	76	-	-	-
ENGINE	85	94	102	-	-	-
RADIATOR	87	96	106	-	-	-
EXHAUST	81	93	101	100	106	109
AIR INTAKE	-	-	-	-	-	-
CABIN	64	70	79	79	92	94

	FRONT	REAR
Tyres: MICHELIN	11 R 22,5	11 R 22,5
Rolling noise at 7,5 m	50 km/h: 73 dB(A)	70 km/h: -



The Engine

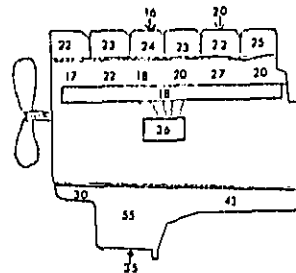

Vibration Levels  
Velocity mm/sec

SPECTRA FROM BEDFORD TM 1500

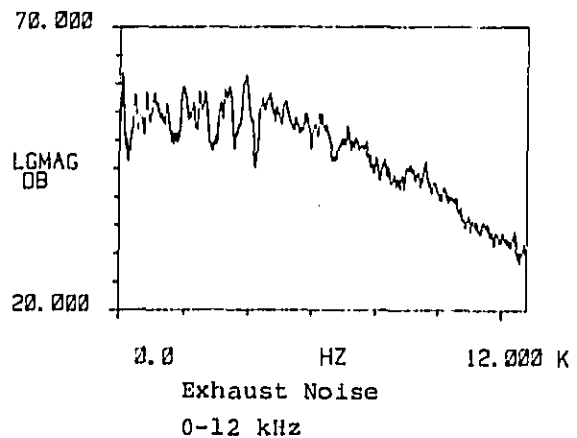
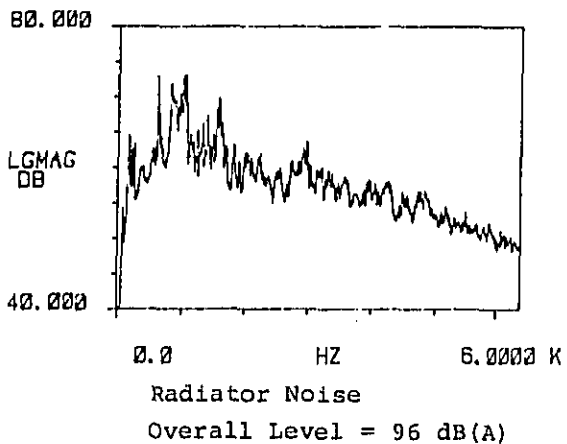
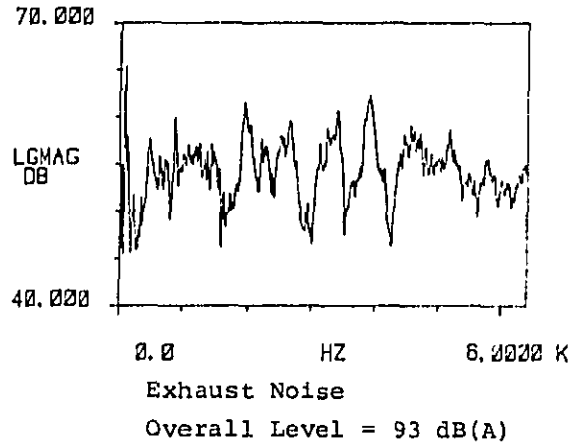
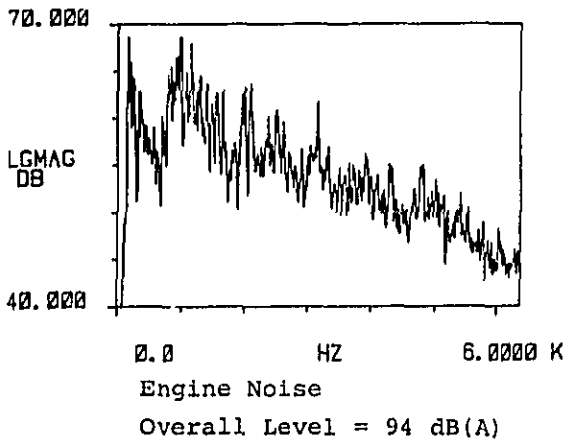
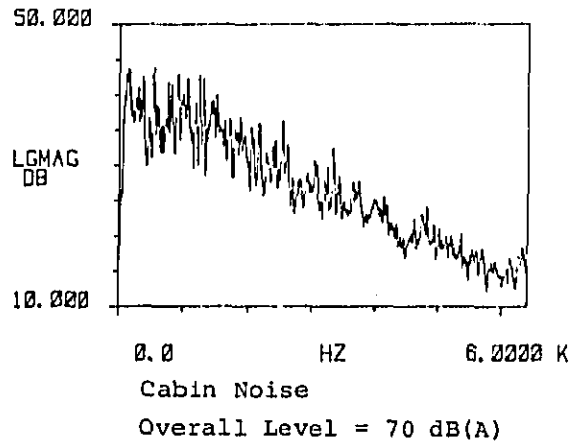
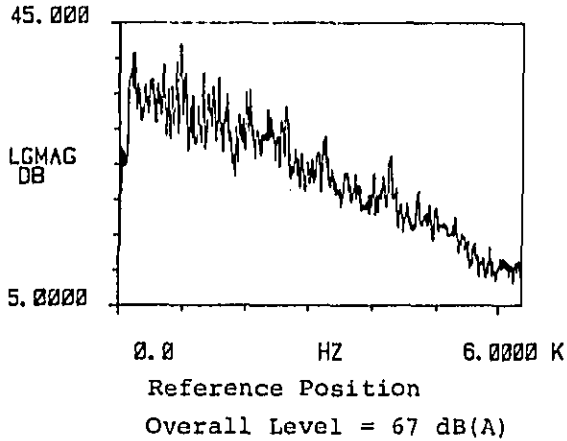

Bedford\_TM\_1500

Radiator noise is the major source, followed by the exhaust and engine noise.

In the radiator position the blade passage frequency at 213 Hz together with its 3rd, 4th and 5th harmonic is clearly visible in the spectrum. Hence the fan noise seems to dominate over forward radiated engine noise, and another fan would be required to reduce the overall noise level of the vehicle significantly.

The exhaust noise is surprisingly broad banded with a distinct peak at low frequencies. The low frequency peak is probably below the cut off frequency of the exhaust system, while the peaks of higher frequencies can stem from regenerated noise due to turbulent flow created in the exhaust system, leaks, structural radiation from the muffler or be due to resonances in the muffler causing transmission of sound energy at distinct frequencies.

The engine noise has one peak at low frequency caused by the cyclic exciting forces in the engine, while the main energy around 1 kHz probably is due to structural resonances being excited. The vibration plot suggests that the oil pan is the major noise radiator on the engine.

The fairly low engine noise level, may be due to the large displacement of the engine compared to the power output, yielding relatively low cylinder pressure.

FIAT 79-F-13



The lightest vehicle in this investigation. The same engine is also used in the models 90F.13 and 100F.13 with GVWs of 9000 kg and 10600 kg respectively.

The engine had the highest maximum engine speed of all the vehicles at 3200 RPM.

IDLE = 700 RPM, S/2 = 1950 RPM,  
MAX = 3200 RPM

RESULTS

ENGINE SPEED	A-weighted sound pressure level dB(A)			Linear sound pressure level dB		
	IDLE	S/2	MAX.	IDLE	S/2	MAX.
REFERENCE POSITION (15 m)	56	67	75	67	72	79
ENGINE	87	97	104	-	-	-
RADIATOR	84	96	108	-	-	-
EXHAUST	74	88	99	93	97	104
AIR INTAKE	78	96	103	93	105	110
CABIN	58	65	76	88	96	92

	FRONT	REAR
Tyres: MICHELIN	8,5 R 17,5	8,5 R 17,5
Rolling noise at 7,5 m	50 km/h: 70 dB(A)	70 km/h: 75 dB(A)



The Engine

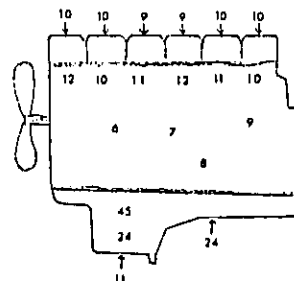

Vibration Levels  
Velocity mm/sec

## SPECTRA FROM FIAT 79-F-13

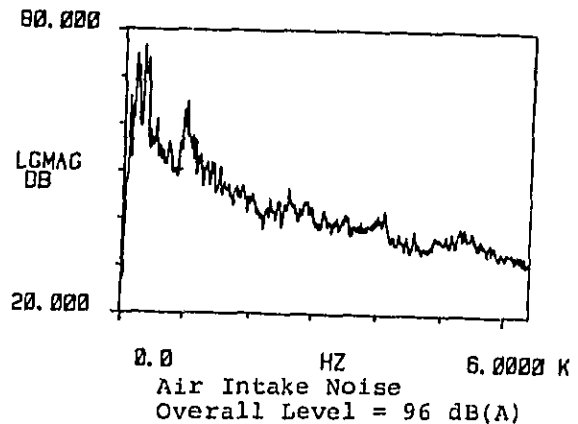
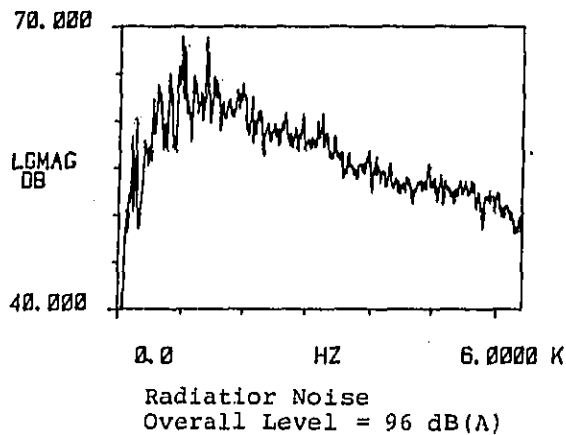
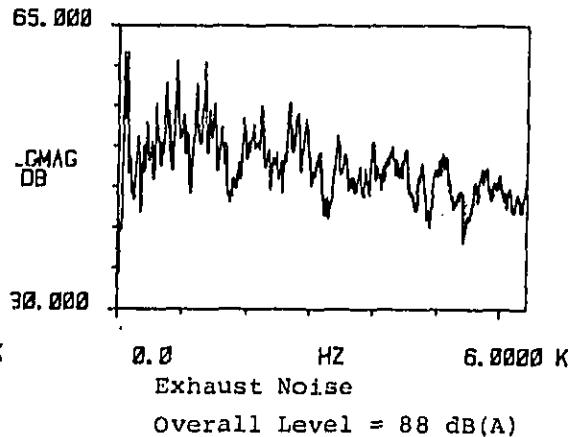
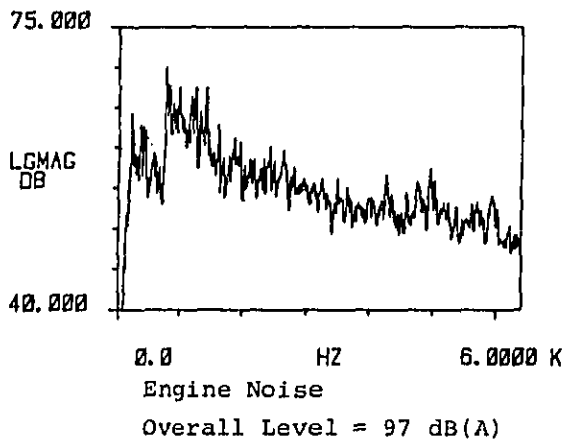
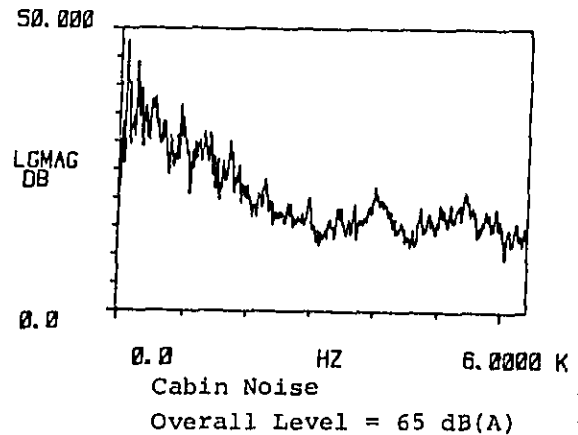
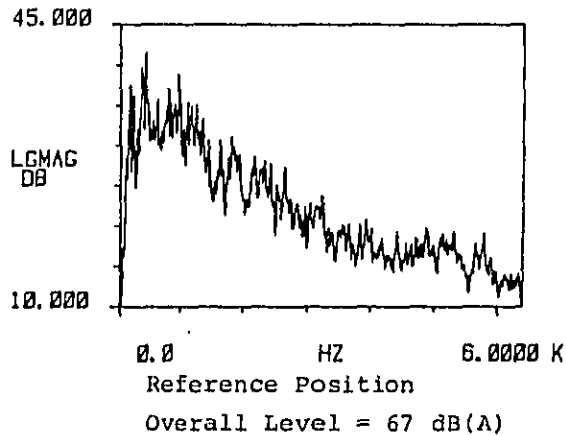

Fiat 79-F-13

The engine was the most intense noise source, closely followed by the radiator, while the exhaust and air intake-noise is less important.

The engine has most of its noise energy between 1 and 2 kHz, which implies radiation due to structural modes. The vibration plot display generally low amplitudes apart from the side of the oil pan, which seems to be a weak point.

The blade passage frequency of the fan is just weakly visible, so the fan noise is either contaminated with engine noise or mainly broad band.

The exhaust noise is well damped and consists mainly of regenerated turbulence noise.

The air intake is placed above the roof of the cabin. The noise from the intake is only significant below 500 Hz.

The cabin noise is low in overall level, but has a significant low frequency contribution.



MAGIRUS 160M 13FL



This vehicle has an air cooled turbo charged engine.

Other Magirus models are Supplied with the same engine without turbo-charging, and a 4 cylinder engine with the same cylinder dimensions is also available .

IDLE = 700 RPM, S/2 = 1700 RPM,  
MAX = 2650 RPM

RESULTS

ENGINE SPEED	A-weighted sound pressure level dB(A)			Linear sound pressure level dB		
	IDLE	S/2	MAX.	IDLE	S/2	MAX.
REFERENCE POSITION (15 m)	57	67	77	70	75	84
ENGINE	87	97	106	-	-	-
RADIATOR	-	-	-	-	-	-
EXHAUST	77	90	98	95	103	108
AIR INTAKE	-	-	-	-	-	-
CABIN	65	70	76	95	84	88

FRONT

REAR

Tyres: MICHELIN	10 R 22,5	10 R 22,5
Rolling noise at 7,5 m	50 km/h: 72 dB(A)	70 km/h: 76 dB(A)

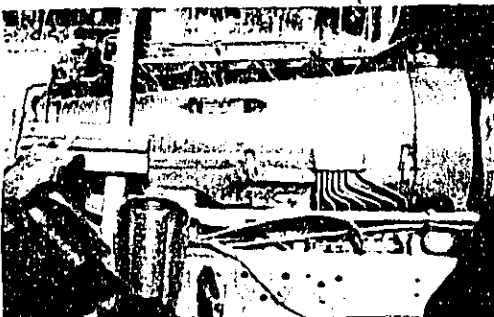

The Engine

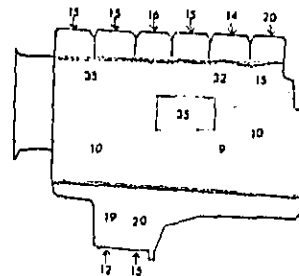

Vibration Levels  
Velocity mm/sec

SPECTRA FROM MAGIRUS 160M 13FL

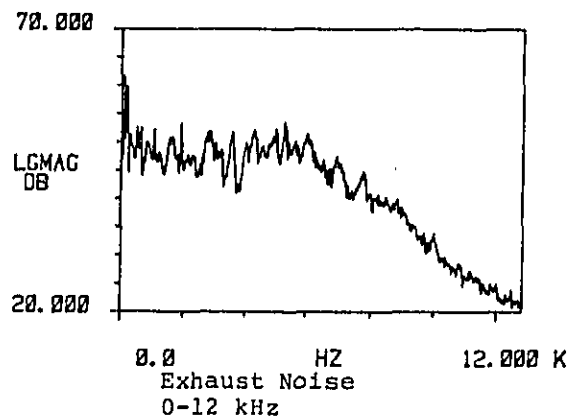
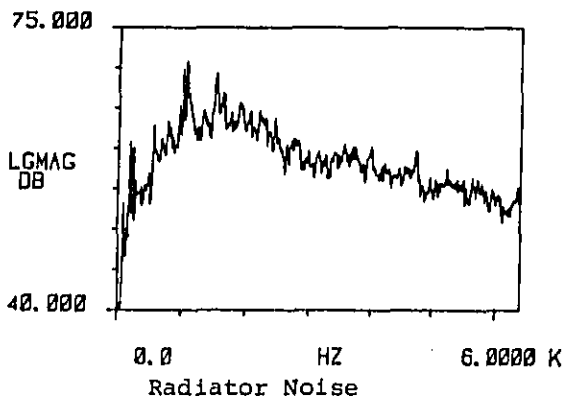
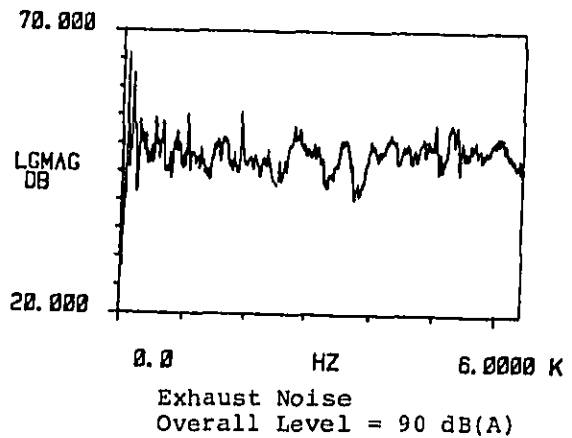
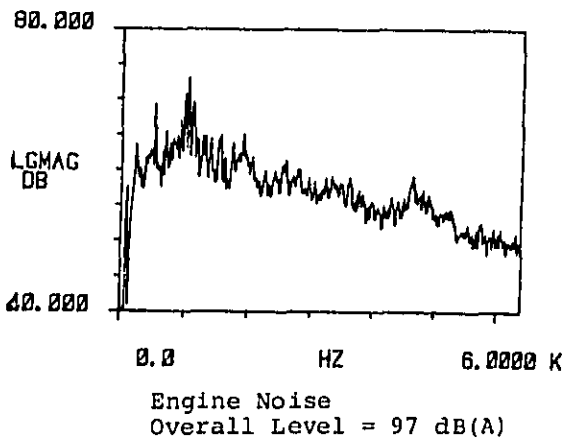
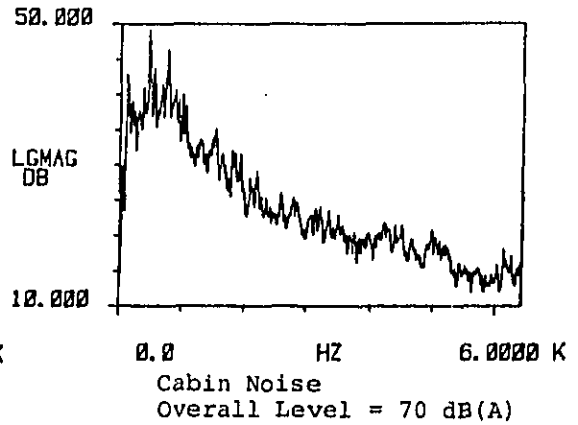
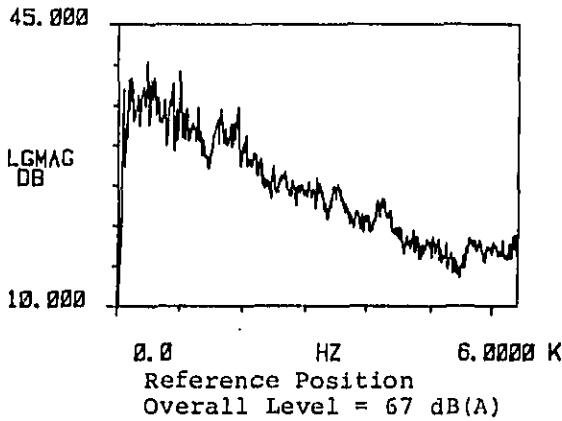

Magirus 160M 13FL

Near field measurements could only be carried out in the exhaust and engine position on this vehicle due to difficulties in positioning the microphones.

The engine noise dominates and have a peak just above 1 kHz, probably due to structural resonances. From the vibration plot it can be seen that this engine has the highest vibration levels on the cylinder walls. This is not suprising since the engine is air cooled and has a light cylinder block.

The exhaust noise has a low overall level. Apart from two peaks below the system cut off frequency, the noise is wide band up to 6 kHz.

The cabin noise has significant contributions at up to 1200 Hz. Two peaks in the spectrum at 450 and 800 Hz indicates room modes in the cabin at these frequencies.

MERCEDES 1217

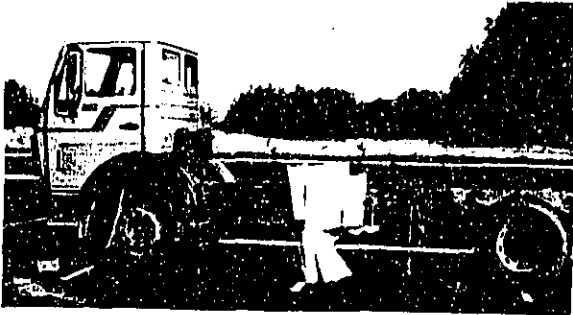

This vehicle has the highest power output of the "Light Trucks".

The engine is turbo charged and has the highest stroke/bore ratio (1,32) of all the vehicles tested.

The engine is used in other Mercedes models up to 16000 kg g.v.w. and is also built without turbo charging.

IDLE = 700 RPM, S/2 = 1750 RPM,  
MAX = 2800 RPM

RESULTS

ENGINE SPEED	A-weighted sound pressure level dB(A)			Linear sound pressure level dB		
	IDLE	S/2	MAX.	IDLE	S/2	MAX.
REFERENCE POSITION (15 m)	60	68	79	73	74	82
ENGINE	89	98	106	-	-	-
RADIATOR	85	97	107	-	-	-
EXHAUST	74	83	93	93	92	96
AIR INTAKE	80	90	102	86	94	108
CABIN	63	70	81	88	86	86

	FRONT	REAR
Tyres: MICHELIN	10 R 22,5 (summer)	10 R 22,5 (winter)
Rolling noise at 7,5 m	50 km/h: 70 dB(A)	70 km/h: 76 dB(A)

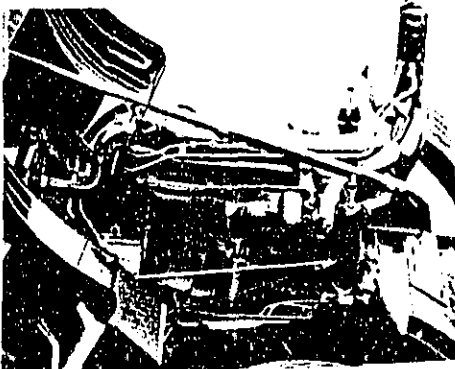

The Engine

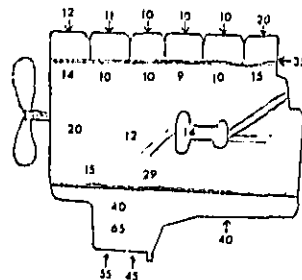

Vibration Levels  
Velocity mm/sec

## SPECTRA FROM MERCEDES 1217

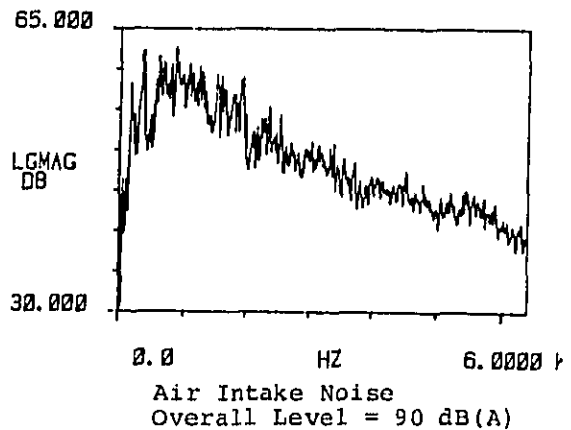
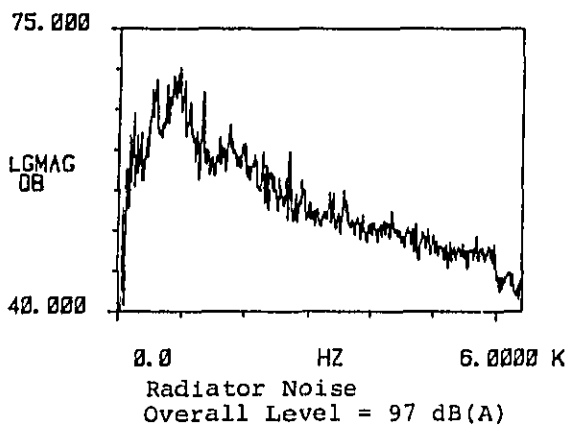
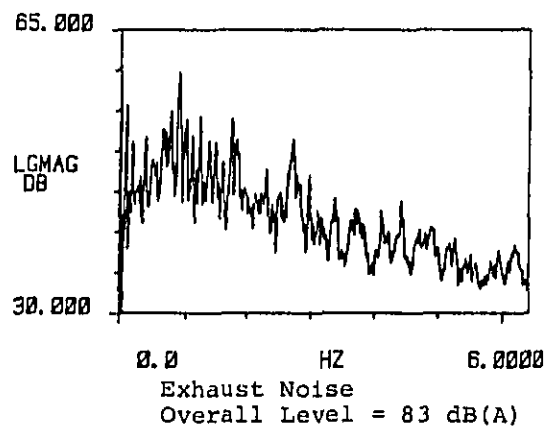
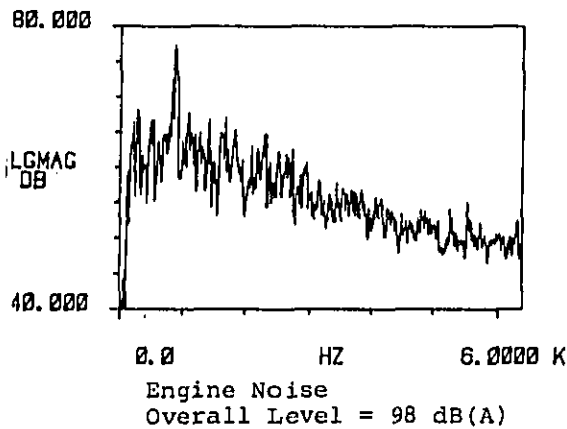
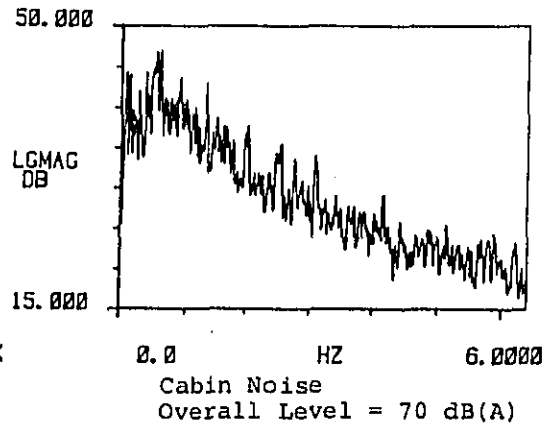
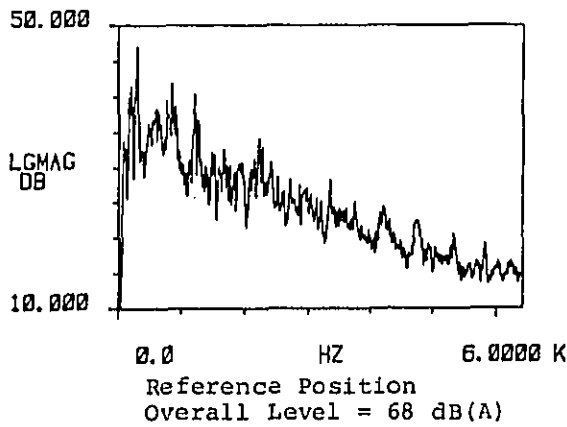

Mercedes\_1217

Engine noise dominates, although noise in the radiator position is important too. Exhaust and intake noise is negligible.

The significant part of the engine noise consists of several small peaks in the frequency range 300 to 3 kHz, and one peak at 950 Hz 10 dB above the others. This peak is most likely due to a resonance in the oil pan, as the vibration level there is 3 times as high as on other parts of the engine.

The noise in front of the radiator is centered around 1 kHz, and seems to consist of a mixture of fan blade passage, turbulence and engine noise.

The air intake was in the right hand corner of the front panel and did not emit significant noise. The spectrum suggests that the engine noise dominates over the air intake noise.

The exhaust noise was the lowest measured and negligible compared with the overall noise emitted from the vehicle. The exhaust system consists of a single reactive muffler with a well dimensioned exhaust pipe.

VOLVO F609



This vehicle was used in a pilot investigation to determine the procedure of measurements.

Results from the pilot investigation can be found in figure 2, section 3.

Volvo has stopped producing this model without a turbo. The equivalent model with a turbo is denoted F610 and produces 113 kW.

IDLE = 600 RPM, S/2 = 1700 RPM,  
MAX = 2800 RPM

RESULTS

ENGINE SPEED	A-weighted sound pressure level dB(A)			Linear sound pressure level dB		
	IDLE	S/2	MAX.	IDLE	S/2	MAX.
REFERENCE POSITION (15 m)	58	67	77	73	75	84
ENGINE	84	97	104	-	-	-
RADIATOR	84	94	103	-	-	-
EXHAUST	81	90	100	87	96	102
AIR INTAKE	83	96	106	103	108	112
CABIN	62	69	76	94	81	86

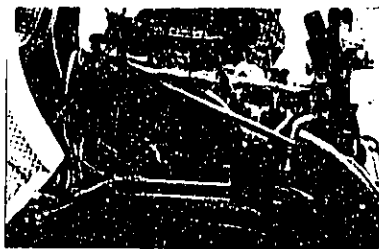

The Engine

SPECTRA FROM VOLVO F609

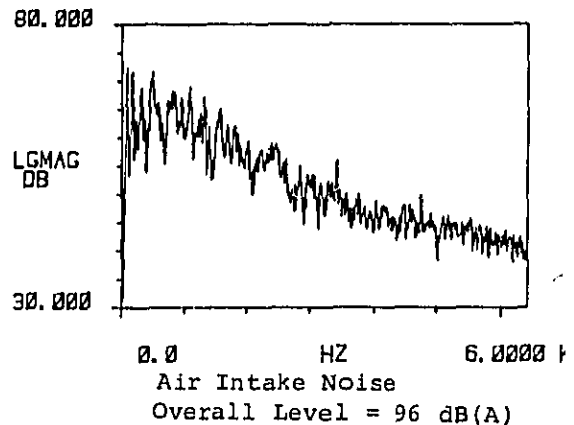
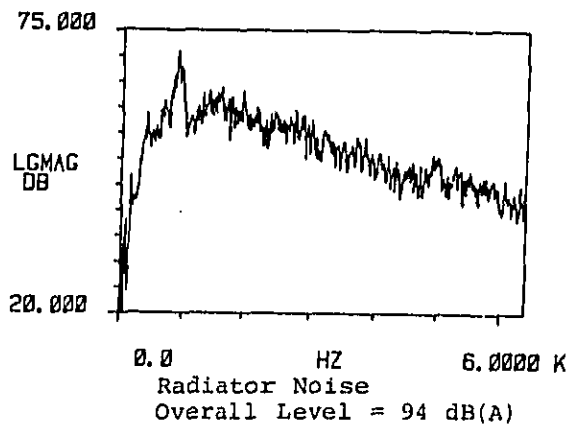
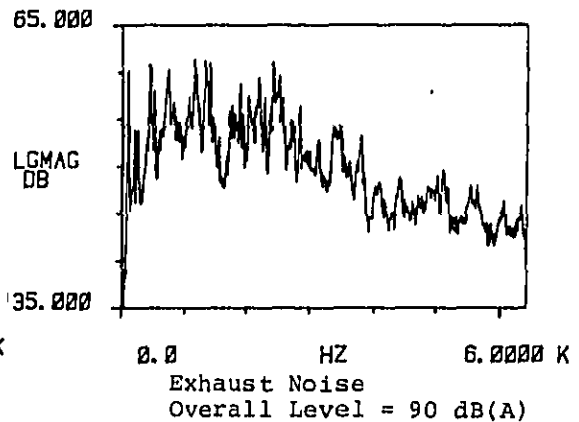
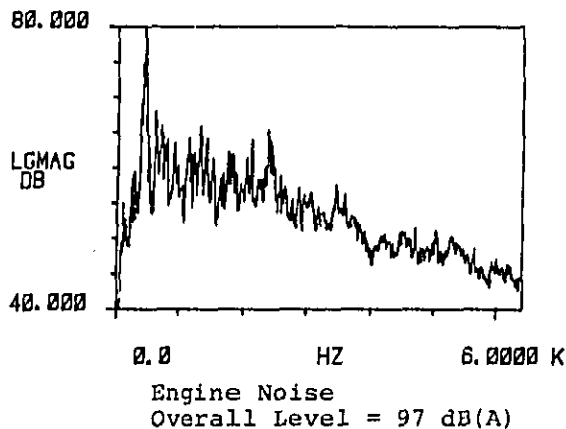
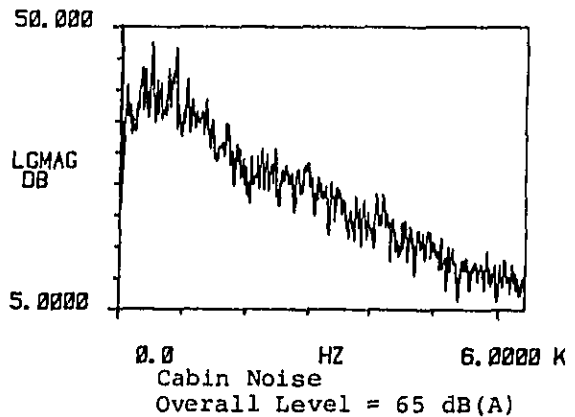
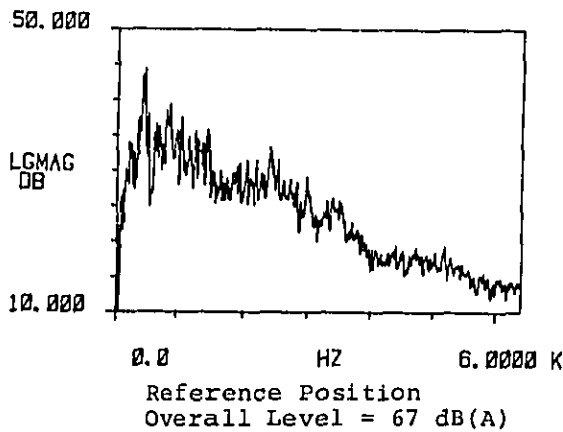



Volvo\_F609

The engine noise dominates, but the air intake exhaust and fan all contribute to the overall noise emitted from the vehicle.

The engine noise is dominated by a peak at 450 Hz, probably due to an oil pan resonance. The oil pan had little stiffness and vibrated well.

The first four harmonics of the blade passage frequency are visible on the radiator noise spectrum, though fan turbulence seems to be just as important.

The air intake noise is suprisingly strong up to 1500 Hz, suggesting that both pulse noise and flow turbulence is a problem.

The cabin noise has its main energy below 1500 Hz. The two peaks at 500 and 900 Hz are probably due to room modes in the cabin.

FORD TRANSCONTINENTAL 4432



This vehicle consists of components from several companies. The engine is a Cummins TE350 with turbo charging and intercooling, and is a so called "big cam" version with 4 valves per. cylinder. The vehicle can also be supplied without intercooling giving a power output of 201 kW or in a more powerful version yielding 259 kW. The cabin is equipped with a sleeping compartment.

IDLE = 650 RPM, S/2 = 1300 RPM, MAX = 2000 RPM

RESULTS

ENGINE SPEED	A-weighted sound pressure level dB(A)			Linear sound pressure level dB		
	IDLE	S/2	MAX.	IDLE	S/2	MAX.
REFERENCE POSITION (15 m)	61	69	75	77	83	86
ENGINE	90	98	102	-	-	-
RADIATOR	85	94	100	-	-	-
EXHAUST	83	96	100	107	112	113
AIR INTAKE	82	89	95	92	95	101
CABIN	64	68	74	87	89	93

FRONT

REAR

Tyres: MICHELIN	315/75x22,5 (summer)	315/70x22,5 (winter)
Rolling noise at 7,5 m	50 km/h: 75 dB(A)	70 km/h: 80 dB(A)



The Engine

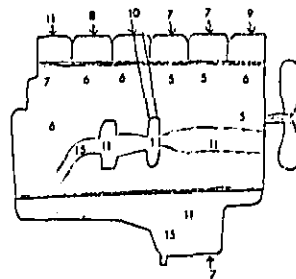

Vibration Levels  
Velocity mm/sec

SPECTRA FROM FORD TRANSCONTINENTAL 4432

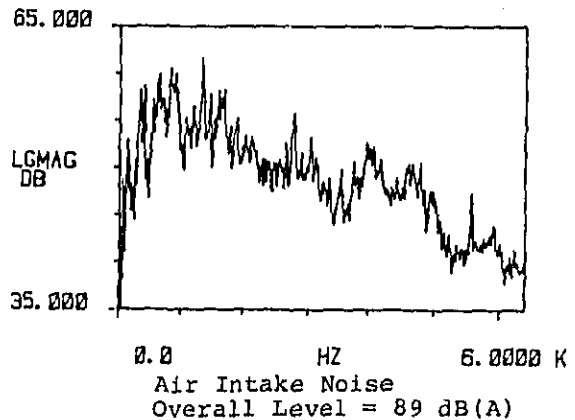
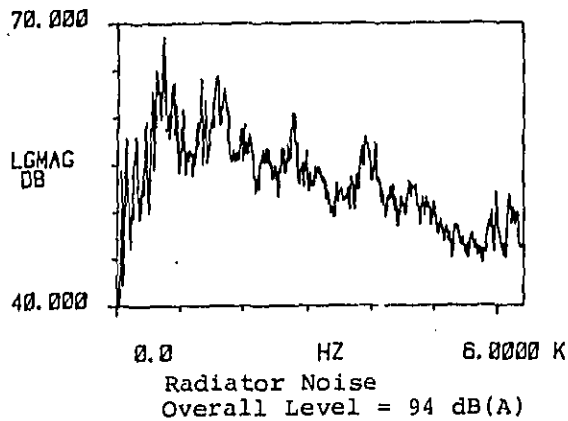
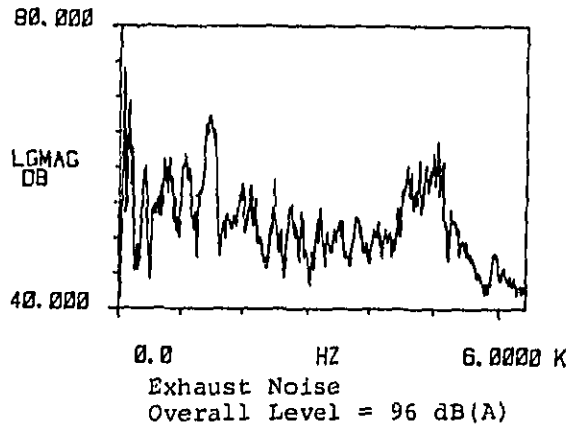
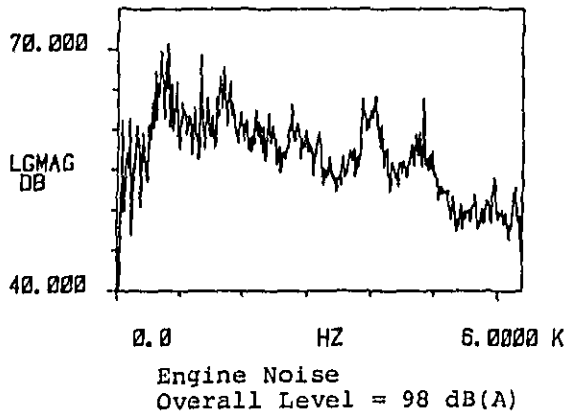
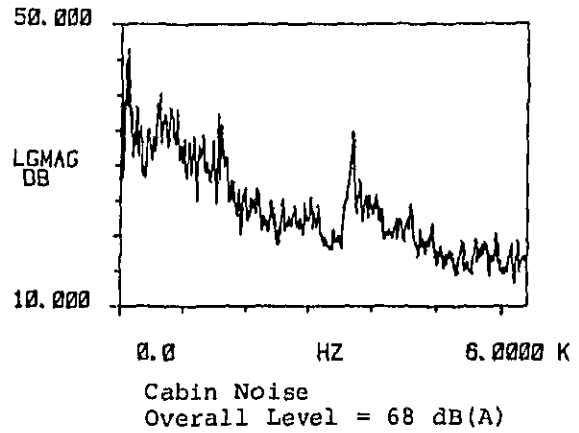
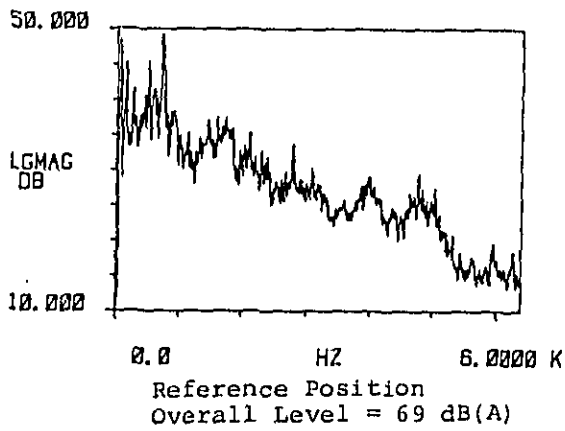

Ford\_Transcontinental\_4432

The engine noise had the highest level with the exhaust noise close second, the radiator noise was well below and the air intake noise negligible.

The engine noise had most of it's energy between 600 and 2 kHz, but it also had significant contributions as high as 5 kHz, Cummins has put additional stiffness into the engine block with extra horizontal ribs. [8]. This may be the reason for the high frequency modes. The vibration plot shows generally low vibration levels for the complete engine.

The exhaust was noisy with a very significant low frequency level (note the linear level). The exhaust system is clearly inadequate for frequencies below 200 Hz. The peak at 1500 Hz is most likely due to a resonance in the muffler, while the high frequency noise at 5 kHz is regenerated flow noise.

Noise in the radiator position appears to stem from the engine. The vehicle had temperature controlled fan and a Venetian blind in front of the radiator. The fan was operating and the blind open during the measurements.

The air intake was behind the front panel and did not emit significant noise. The spectrum shows that the noise registered in this position is contaminated by engine noise.

MAGIRUS 320 m 19FL



The vehicle has an air cooled, naturally aspirated V10 engine with an impressive displacement of 15,95 L.

The engine is used in several other Magirus models and engines with the same cylinder dimensions are also produced in V6 and V8 configurations.

When these engines succeeded the old V6, V8 and V10 engines a couple of years ago, the displacement was increased slightly and the noise control improved in several ways.

The cabin is equipped with a sleeping compartment.

IDLE = 600 RPM, S/2 = 1600 RPM,  
MAX = 2500 RPM

RESULTS

ENGINE SPEED	A-weighted sound pressure level dB(A)			Linear sound pressure level dB		
	IDLE	S/2	MAX.	IDLE	S/2	MAX.
REFERENCE POSITION (15 m)	56	68	75	68	75	86
ENGINE	87	99	105	-	-	-
RADIATOR	87	97	104	-	-	-
EXHAUST	77	96	97	93	99	102
AIR INTAKE	83	103	108	102	116	119
CABIN	58	69	75	87	81	87

FRONT

REAR

Tyres: PIRELLI	13R 22,5	13R 22,5
Rolling noise at 7,5 m	50 km/h: 76 dB(A)	70 km/h: 78 dB(A)

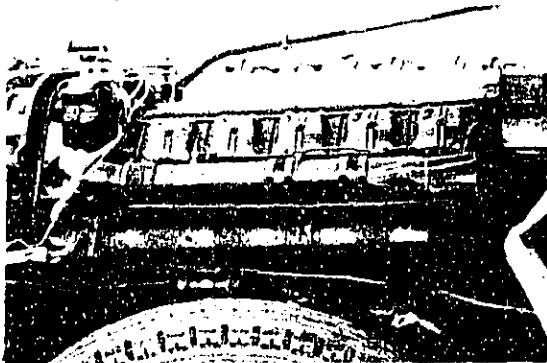

The Engine

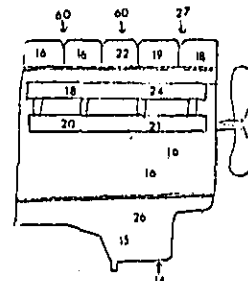

Vibration Levels  
Velocity mm/sec

## SPECTRA FROM MAGIRUS 320 m 19FL

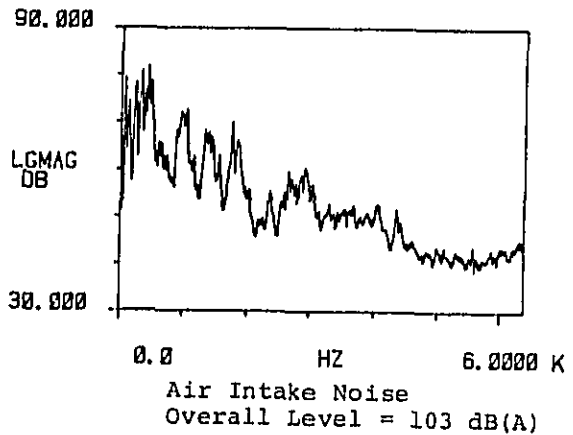
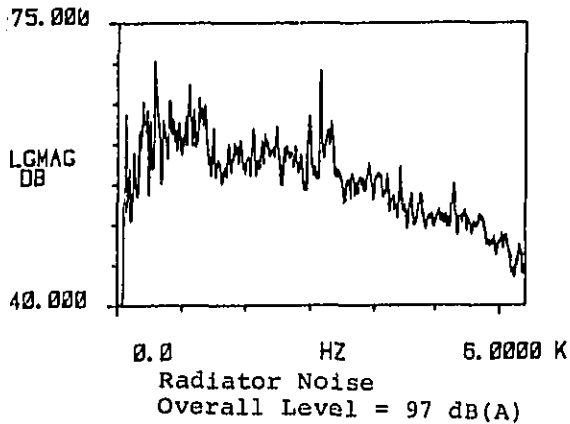
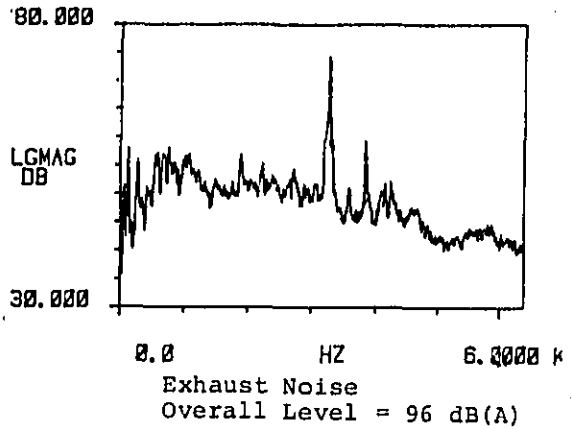
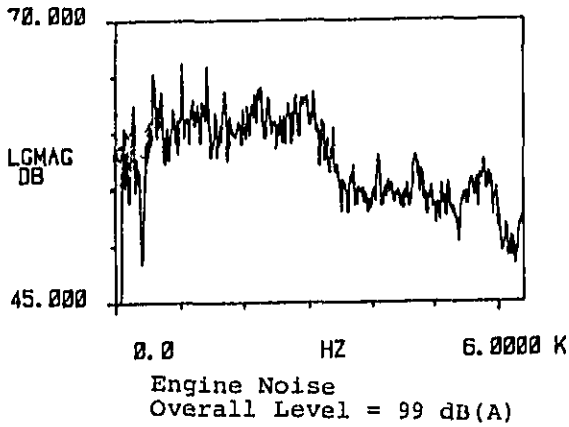
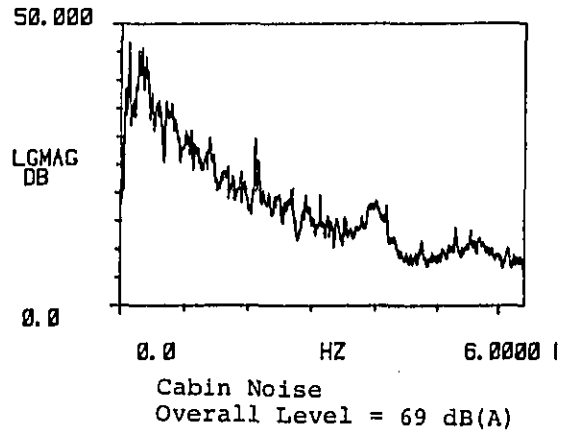
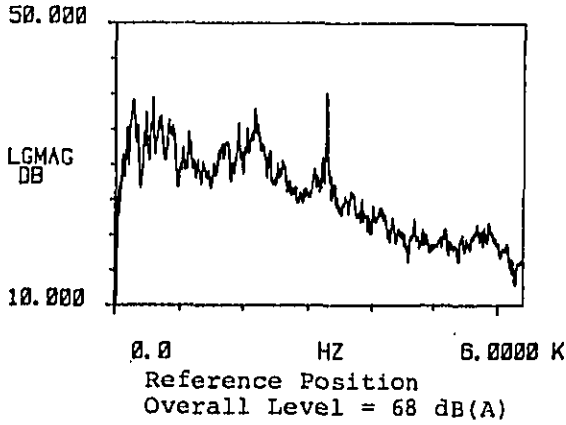

Magirus Deutz 320m 19 FL

The engine is the most important noise source, while air intake noise and "radiator" noise come second and third. The exhaust noise is well below the other sources apart from one discrete frequency component at 3300 Hz for engine speeds between 1200 and 1700 RPM.

The engine noise is centered between 600 and 3300 Hz. The vibration levels on the engine block are generally low, apart from the cover above the cooling air duct which vibrated well.

The air intake was situated above the roof of the cabin and was very noisy. The spectrum shows strong pulse noise components up to 500 Hz and the three peaks between 1 and 2 kHz imply standing waves in the intake system.

Noise in front of the vehicle (radiator position) is strongest between 400 and 1500 Hz and has a discrete component at 3200 Hz. The noise here is probably a mixture of fan and engine noise, with fan turbulence noise dominating between 400 and 1500 Hz.

The exhaust noise was low, but had a whistle tone which was clearly audible in the reference position. Such a whistle tone can be produced by flow disturbance in the exhaust system.

The cabin noise is well attenuated for frequencies above 500 Hz.

M.A.N. 19, 321F

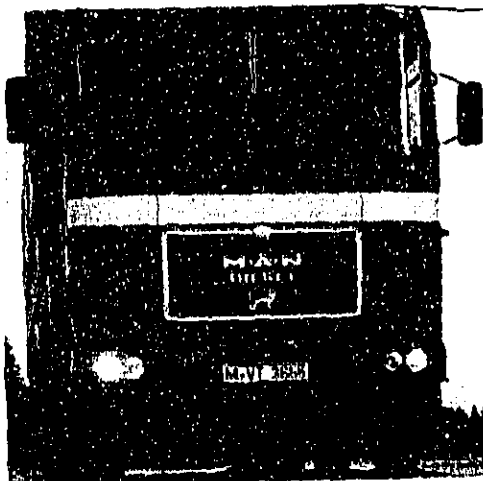

This vehicle was elected "Truck of the year" when introduced in 1979. It has a 6 cylinder in line engine with turbocharging, intercooling and resonant induction. This advanced "feeding" system ensures a flat torque curve and high power output at low speed.

The engine is used in several other M.A.N. models and is also produced without intercooling and turbocharging.

The cabin is equipped with a sleeping compartment.

IDLE = 600 RPM, S/2 = 1350 RPM  
MAX = 1900 RPM.

RESULTS

ENGINE SPEED	A-weighted sound pressure level dB(A)			Linear sound pressure level dB		
	IDLE	S/2	MAX.	IDLE	S/2	MAX.
REFERENCE POSITION (15 m)	57	72	73	72	80	80
ENGINE	85	95	99	-	-	-
RADIATOR	78	88	94	-	-	-
EXHAUST	80	99	103	97	105	107
AIR INTAKE	77	87	92	89	100	104
CABIN	53	61	65	89	89	90

	FRONT	REAR
Tyres: MICHELIN	12R 22,5	12R 22,5
Rolling noise at 7,5 m	50 km/h: 73,5 dB(A)	70 km/h: 77,5 dB(A)



The Engine

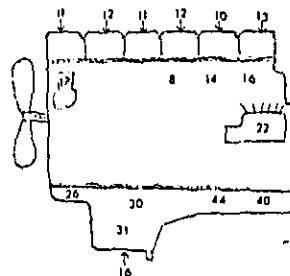

Vibration Levels  
Velocity mm/sec



SPECTRA FROM M.A.N. 19.321F

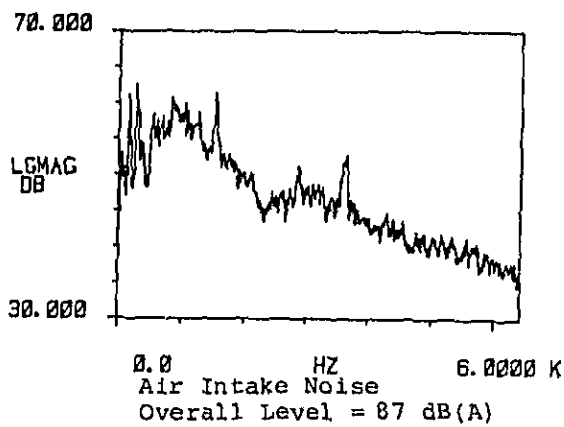
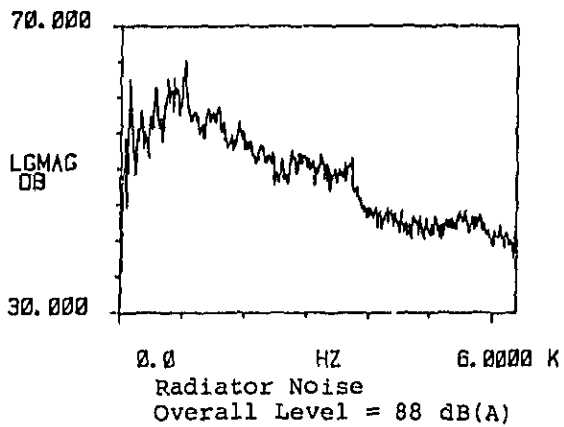
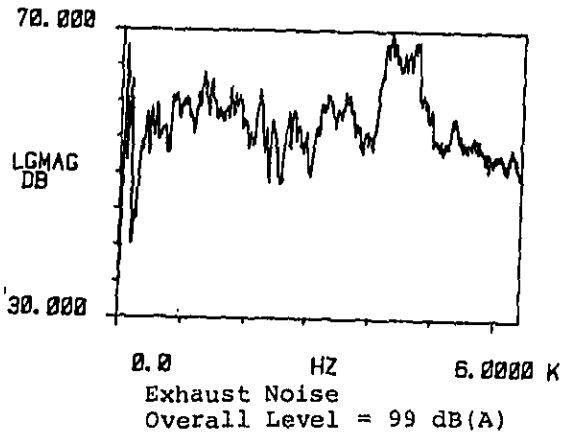
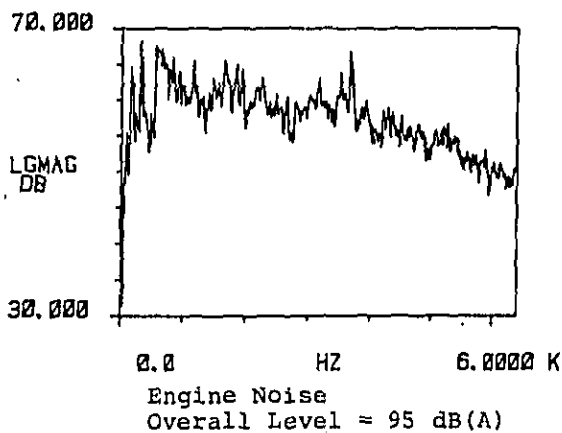
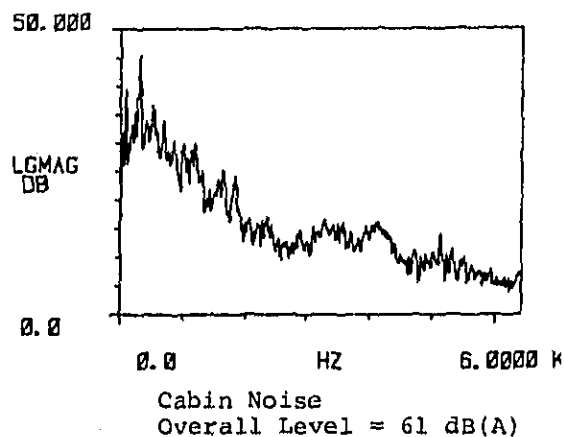
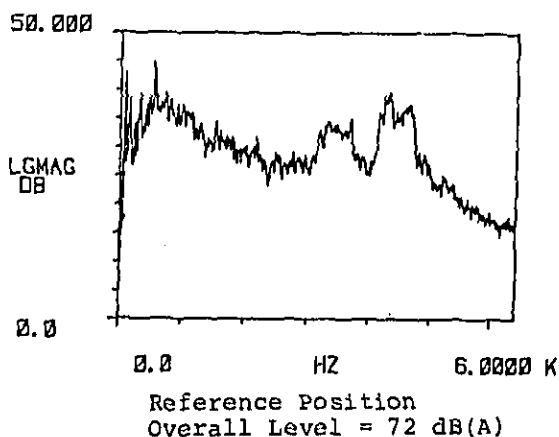

M.A.N. 19, 321F

The exhaust is the dominating noise source on this vehicle, having the highest level of all the vehicles in the series. The other sources have very low levels, although the engine noise does contribute slightly to the noise in the reference position around 600 Hz.

The exhaust noise consists of low frequency pulse noise below the cut-off frequency of the muffler (approx. 200 Hz). The level above 500 Hz is generally high and two frequency bands stand out between 3 and 5 kHz. The engine had an advanced induction system, which obviously increases the gas flow through the engine. The possibility of regenerated flow and leak noise increases with the strength of the flow and the exhaust system is obviously not an optimal design.

On the other hand the induction system seems to have had a positive influence on the other sources. The low level of the engine noise is probably due to a smooth pressure rise in the cylinders and hence low exciting forces due to combustion.

The radiator noise level was low, although the first five fan blade passage harmonics can be seen in the spectrum. The fan was temperature controlled and will only operate when necessary.

The air intake was positioned in the right hand corner of the front panel and did not emit significant noise.

The cabin had a very low noise level with one room mode at 300 Hz dominating.

MERCEDES 1932 LS

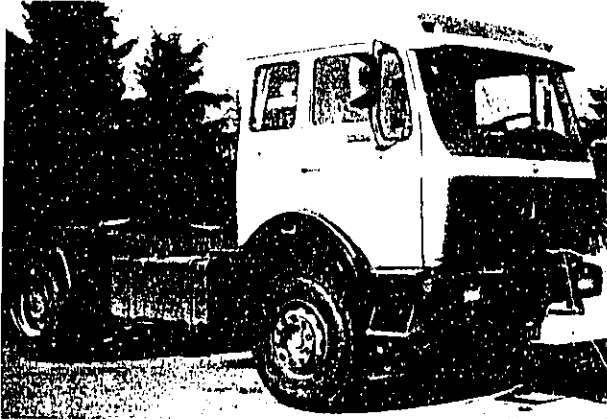

The 1932 LS is equipped with a water cooled, naturally aspirated V10 engine with 15.95 l displacement. The engine has, apart from the water cooling, got the same technical data as the big Magirus engine. The Mercedes engine factory OM is a member of the Industrial vehicle cooperation IVECO, which consist of Magirus, OM, Fiat and Unic, and they do much of

their development work is cooperation. Mercedes uses this engine in several other models, and it is also prodeded in V6 and V8 configuration. The cabin as got a sleeping compartment.

IDLE = 700 RPM, S/2 = 1100 RPM, MAX = 2500 RPM.

RESULTS

ENGINE SPEED	A-weighted sound pressure level dB(A)			Linear sound pressure level dB		
	IDLE	S/2	MAX.	IDLE	S/2	MAX.
REFERENCE POSITION (15 m)	60	70	77	75	81	83
ENGINE	90	100	106	-	-	-
RADIATOR	91	100	107	-	-	-
EXHAUST	85	93	100	103	99	105
AIR INTAKE	83	92	99	94	104	104
CABIN	61	69	75	88	86	86

Tyres:	FRONT CONTINENTAL 13R 22,5	REAR MICHELIN 12R 22,5
Rolling noise at 7,5 m	50 km/h: 76,5 dB(A)	70 km/h: 79 dB(A)

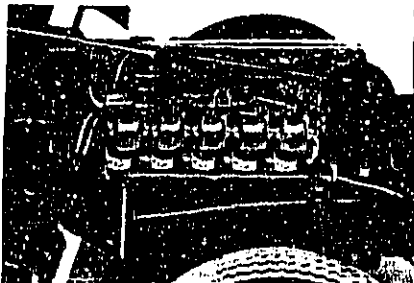

The Engine

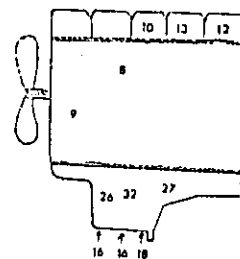

Vibration Levels  
Velocity mm/sec

## SPECTRA FROM MERCEDES 1932 LS

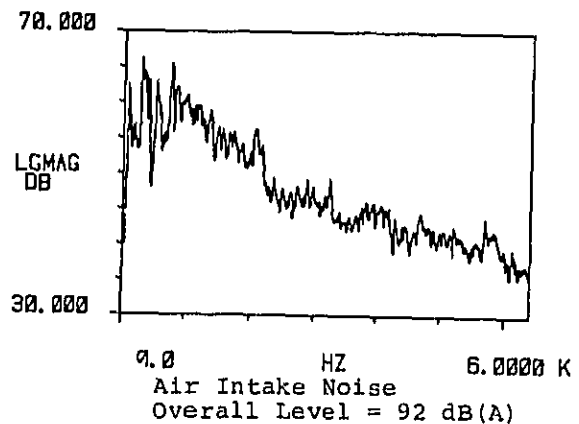
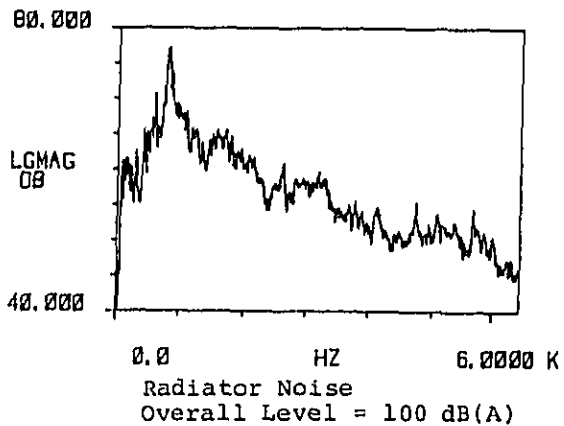
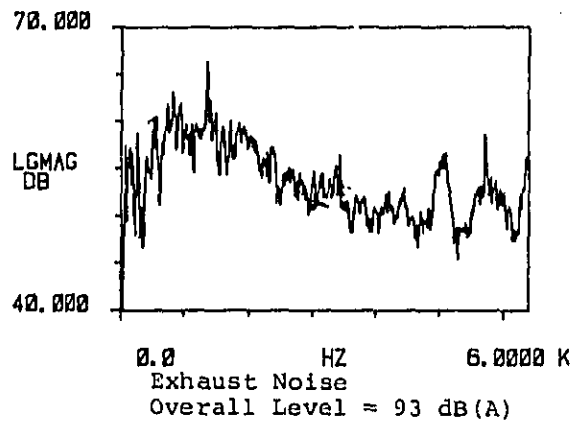
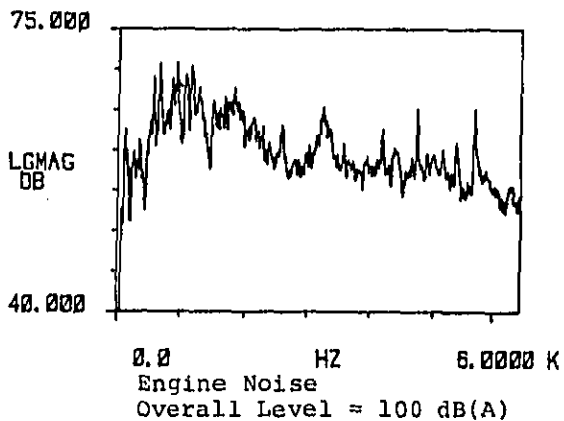
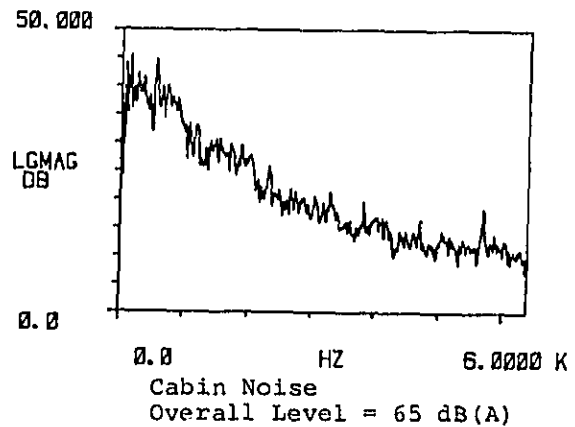
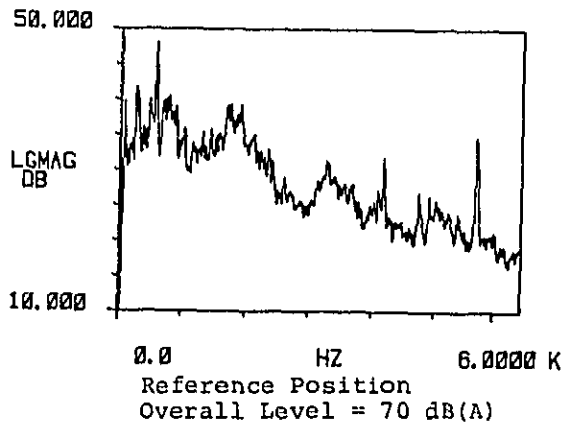

Mercedes\_1932\_LS

The engine is the major noise source, the fourth harmonic of the fan at 853 Hz is significant and the exhaust noise contributes weakly to the overall level. The intake noise is insignificant.

The engine noise has most of it's energy between 600 and 2 kHz. The vibration levels of the engine were low, the oil pan vibrating strongest. The peaks at 4200 Hz and 5700 Hz, clearly seen on the reference, engine and exhaust spectra, were due to looseness in the exhaust manifold/pipe connection exciting two high frequent modes in the exhaust system hardware. Such noises are due to faulty materials or sloppy workmanship rather than the design and can easily be cured.

In the radiator position the first four fan harmonics are visible on the spectrum. The fan is temperature controlled.

The exhaust noise is strongest between 500 and 2500 Hz and contributes weakly to the overall noise level in this critical frequency region.

SCANIA L 141



This normal control vehicle has got a turbo charged V8 engine, with displacement 14,5 l and power output 375 Hp (DIN).

Scania has recently replaced this model with a new one, the T 141. This model has got a brand new cabin design, but uses the same engine and gearbox. The factory claims a noise reduction in the cabin of 3 dB(A) on the new model [9]. The engine is also used in some of Scania's forward control vehicles.  
 IDLE = 600 RPM, S/2 = 1300 RPM,  
 MAX = 2000 RPM.

RESULTS

ENGINE SPEED	A-weighted sound pressure level dB(A)			Linear sound pressure level dB		
	IDLE	S/2	MAX.	IDLE	S/2	MAX.
REFERENCE POSITION (15 m)	61	70	86	68	81	84
ENGINE	90	99	105	-	-	-
RADIATOR	92	99	106	-	-	-
EXHAUST	81	92	100	92	98	105
AIR INTAKE	78	87	91	96	99	102
CABIN	64	71	76	85	91	89

	FRONT	REAR
Tyres: MICHELIN	11,00 R 20	11,00 R 20
Rolling noise at 7,5 m	50 km/h: 72 dB(A)	70 km/h: 76,5 dB(A)



The Engine

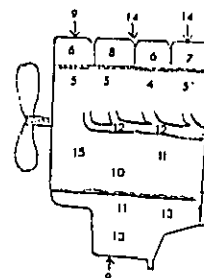

Vibration Levels  
Velocity mm/sec

## SPECTRA FROM SCANIA L141

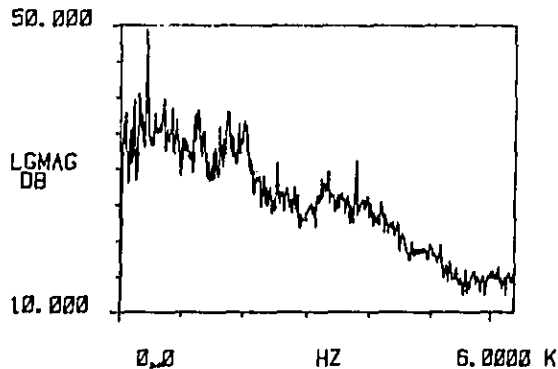

Reference Position  
Overall Level = 70 dB(A)

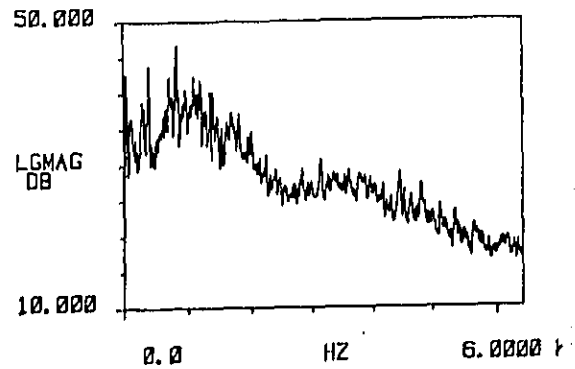

Cabin Noise  
Overall Level = 71 dB(A)

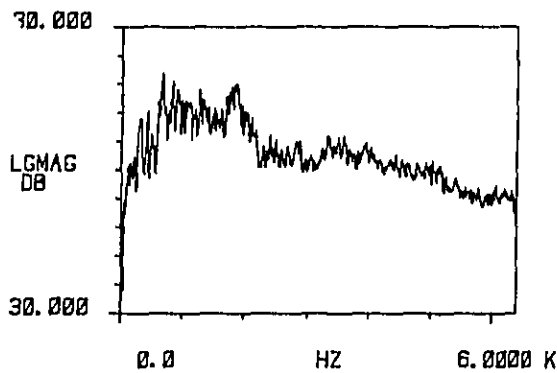

Engine Noise  
Overall Level = 99 dB(A)

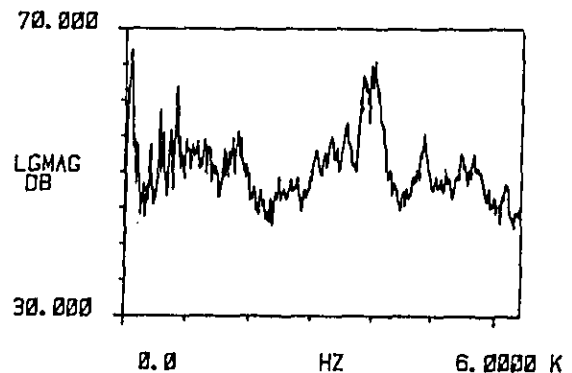

Exhaust Noise  
Overall Level = 92 dB(A)

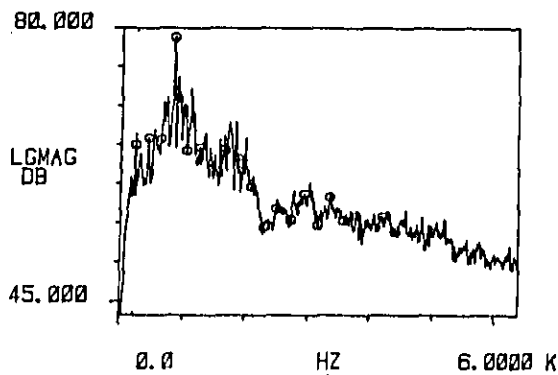

Radiator Noise  
Overall Level 99 dB(A)

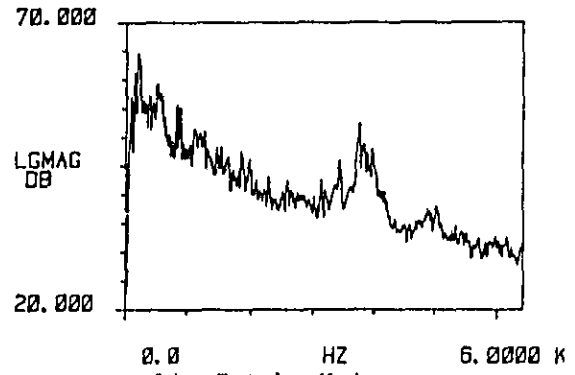

Air Intake Noise  
Overall Level = 87 dB(A)

Scania L 141

This vehicle was generally noisy, apart from the air intake, which had the lowest level in the group. The engine was the strongest noise source followed by radiator and exhaust.

The engine noise has its main energy in the frequency range 700-2300 Hz. The vibration levels of the engine were generally low. The bonnet was made of fairly thin fiberglass and it is suspected that the engine noise may have been transmitted readily through it, losing the attenuating effect usually provided by a bonnet.

The first four fan blade passage harmonics are visible in the spectrum, the fourth having a considerable magnitude. The fan has 10 blades and is temperature controlled.

The exhaust noise has got a strong low frequency component due to pulse noise below the exhaust system cut-off frequency and a wide peak centered around 4 kHz.

A similar peak can be seen in the air intake spectrum and may be the blade passage frequency of the turbocharger. The peak was strongest between 400 and 1200 RPM, rising the overall exhaust noise level with as much as 5 dB(A).

The significant part of the cabin noise extends as high as 2 kHz.



VOLVO F12 INTERCOOLER



The F12 has been in production a couple of years, but the intercooler version was only introduced last year (1979). It has an in line 6 cylinder turbocharged 12 l engine with intercooler and is the most powerful engine in the group.

The engine is also used in other Volvo F12 models.

The cabin is equipped with a sleeping compartment.

IDLE = 600 RPM, S/2 = 1500 RPM, MAX = 2200 RPM.

RESULTS

ENGINE SPEED	A-weighted sound pressure level dB(A)			Linear sound pressure level dB		
	IDLE	S/2	MAX.	IDLE	S/2	MAX.
REFERENCE POSITION (15 m)	60	70	75	70	71	82
ENGINE	86	99	102	-	-	-
RADIATOR	85	99	103	-	-	-
EXHAUST	77	91	98	87	95	105
AIR INTAKE	85	100	104	105	109	112
CABIN	61	67	71	103	98	84

	FRONT	REAR
Tyres: CONTINENTAL	13R 22,5	12R 22,5
Rolling noise at 7,5 m	50 km/h: 75 dB(A)	70 km/h: 77,5 dB(A)



The Engine

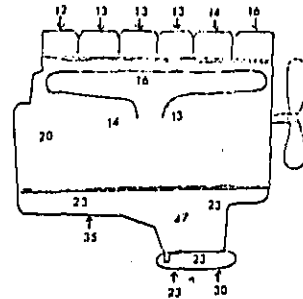

Vibration Levels  
Velocity mm/sec

SPECTRA FROM VOLVO F12

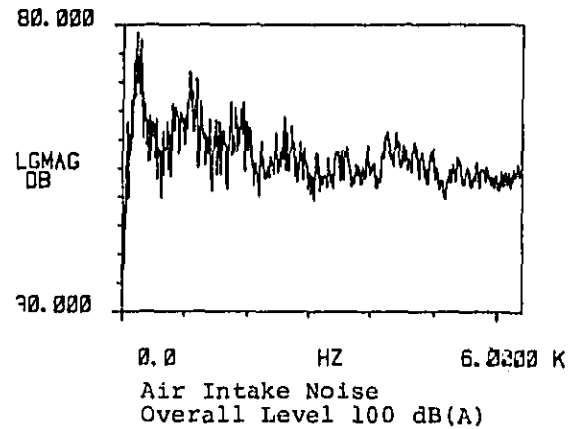
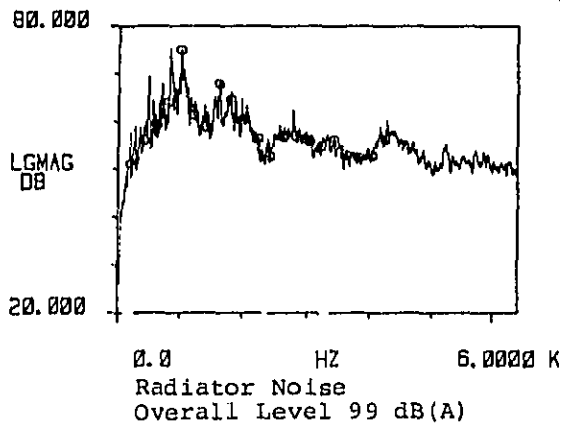
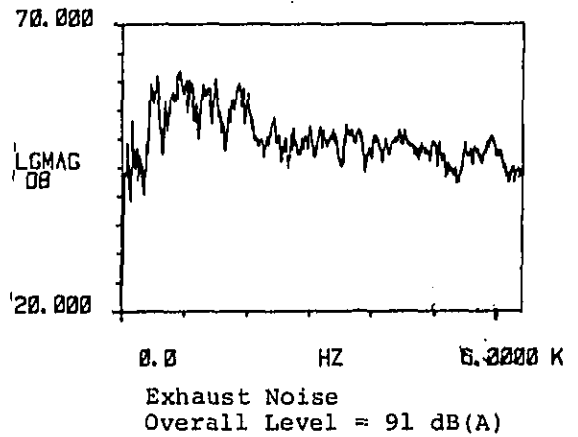
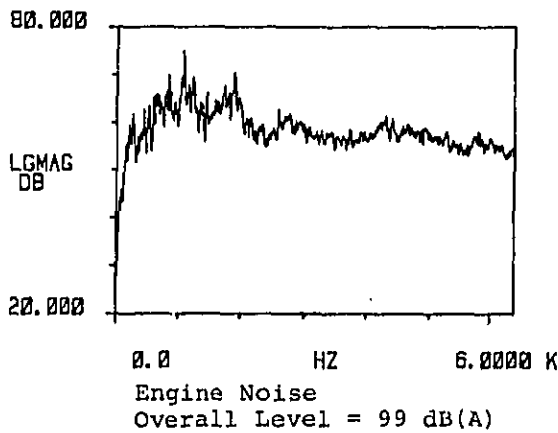
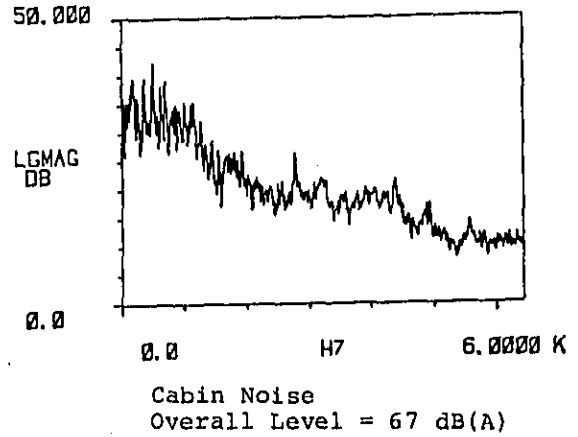
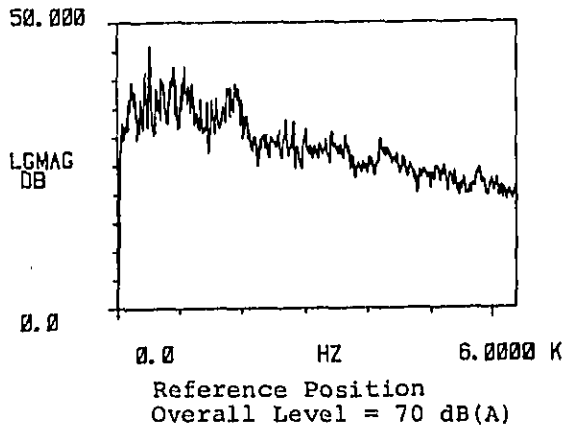

Volvo Fl2 Intercooler

The engine noise dominates, followed by radiator, exhaust and air intake noise in that order.

The engine noise is most important in the frequency range 500 to 2200 Hz, with peaks at 1 and 2 kHz indicating structural modes in the engine block. The vibration plot shows strong vibrations on the side of the oil pan.

The spectrum from the radiator position has much of the same appearance as the engine noise spectrum. It therefore looks like forward radiated engine noise dominates over the fan noise in this position. The fan was temperature controlled, but did run during the measurement.

The exhaust noise has much of it's energy in the same frequency range as the engine noise, however, the overall level is low.

The air intake noise is strong from 200 to 300 Hz. This vehicle should have had an air intake system extending above the cabin roof, but the duct from the air filter to the roof was not mounted. When the intake system is complete the noise character and level will probably be different.

The A-weighted level is low in the cabin, but the noise has a considerable low frequency content.

VOLVO N12

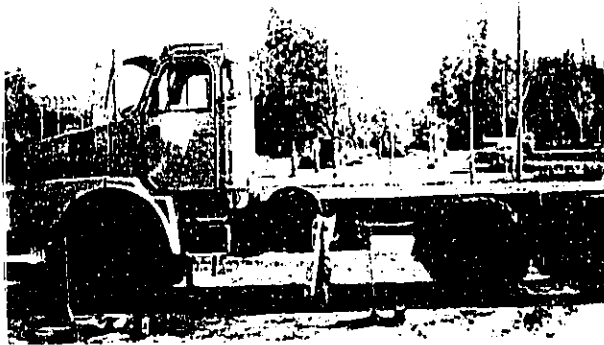

This normal control model from Volvo has got the same engine block as the F12, but differently tuned and without the intercooler. The arrangement of the ancillary equipment is also slightly different. In 1979 the engine version TD120E was introduced especially tuned for heavy construction site transport and the sound insulation of the cabin was improved [10].

IDLE = 600 RPM, S/2 = 1500 RPM, MAX = 2200 RPM.

RESULTS

ENGINE SPEED	A-weighted sound pressure level dB(A)			Linear sound pressure level dB		
	IDLE	S/2	MAX.	IDLE	S/2	MAX.
REFERENCE POSITION (15 m)	61	71	76	78	80	86
ENGINE	90	99	105	-	-	-
RADIATOR	87	98	104	-	-	-
EXHAUST	82	93	100	87	98	111
AIR INTAKE	84	99	101	117	111	110
CABIN	61	69	75	89	87	91

FRONT

REAR

Tyres: MICHELIN	11,0 x 20 (SUMMER)	11,0 x 20 (WINTER)
Rolling noise at 7,5 m	50 km/h: 75 dB(A)	70 km/h: 79 dB(A)

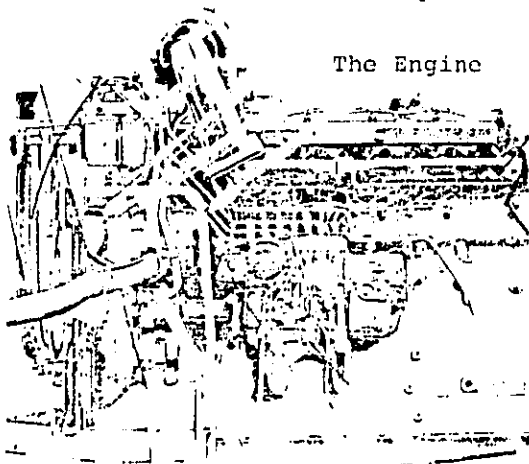

The Engine

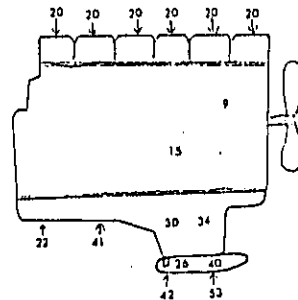

Vibration Levels Velocity mm/sec

## SPECTRA FROM VOLVO N12

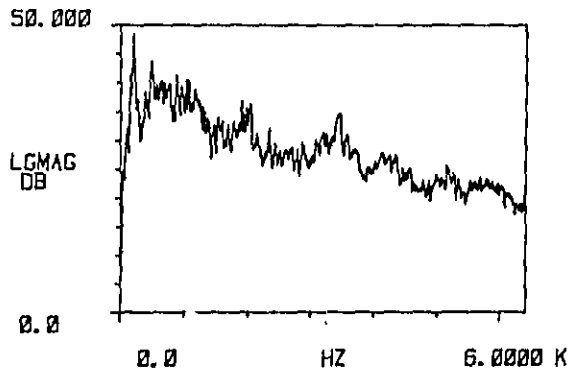

Reference Position  
Overall Level = 71 dB(A)

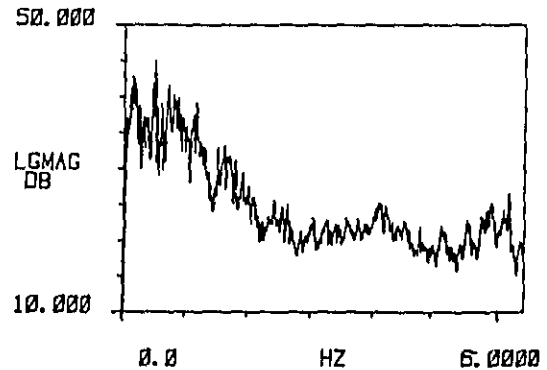

Cabin Noise  
Overall Level = 69 dB(A)

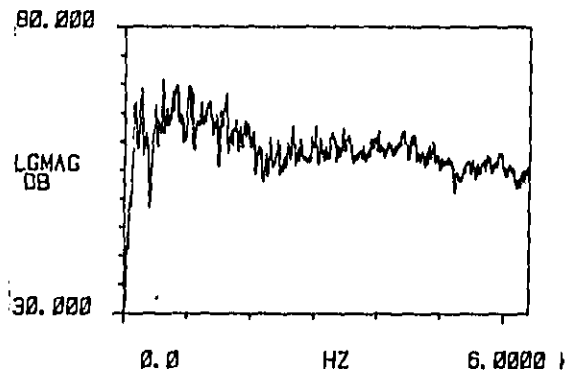

Engine Noise  
Overall Level = 99 dB(A)

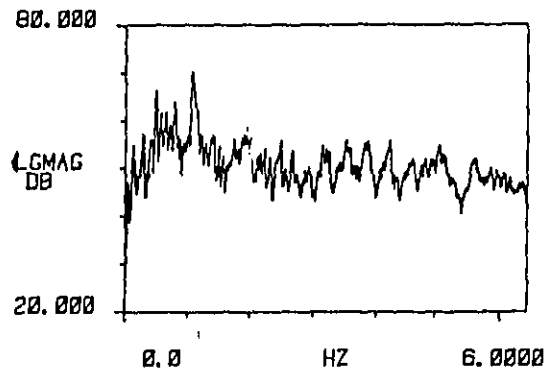

Exhaust Noise  
Overall Level = 93 dB(A)

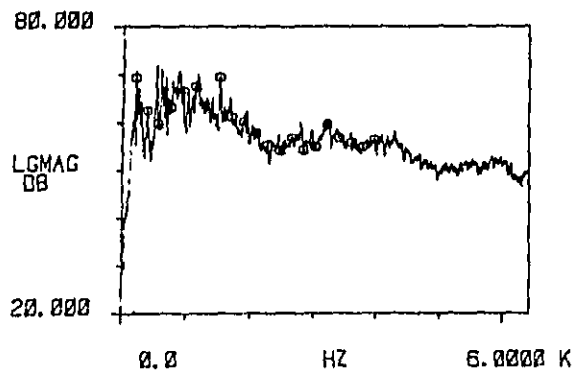

Radiator Noise  
Overall Level = 98 dB(A)

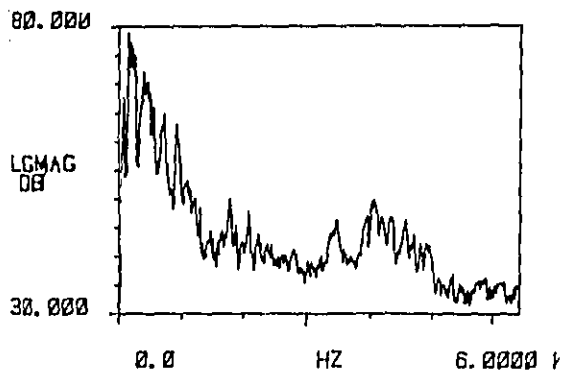

Air Intake Noise  
Overall Level = 99 dB(A)

Volvo N12

The engine is the major noise source with the exhaust and radiator as number two and three.

The engine noise has much of the same character as the engine noise from the F12, but with significant energy further down in frequency. The vibration plot indicates that the oil pan is the strongest noise radiator on the engine, and it can be seen that the vibration characteristics are somewhat different from those of the K12.

The exhaust noise is broad band apart from a peak at 1100 Hz, implying that flow turbulence is the noise source.

The spectrum from the radiator position, indicates that forward radiated engine noise dominates over fan noise.

The vehicle had two air intakes, one on each side of the bonnet. The two air ducts were connected through a T junction to the turbo. The noise from the air intakes fluctuated heavily as the engine speed changed, was low frequent and contributed to the noise in the reference position.

## 7. COMPARISON AND DISCUSSION OF THE RESULTS

The results will be discussed for each of the four major noise sources, then their results will be summated and compared with the results from the reference position. Finally rolling noise and noise in the cabins will be discussed.

### 7.1. Engine Noise

The engine was the strongest noise source for all the vehicles apart from Bedford, Fiat and M.A.N.

The increase in A-weighted noise level versus engine speed is approximately linear with a slope of 10 dB pr. 1000 RPM, figure (11).

The level varies 4-5 dB(A) between the least and most noisy vehicle in each group for a given engine speed.

The average level for the heavy trucks at a given engine speed is 5 dB(A) above the average for the light trucks.

There does not appear to be any correlation between engine performance and noise emission within each group.

#### Light Trucks

The Bedford TM 1500 and the Fiat 79F13 had the least noisy engines in the group, the other engines emitted approximately the same noise level. These engines had the smallest Stroke/Bore ratio in the group, and were naturally aspirated while two of the other engines in the group were turbocharged.

The main exciting forces in an engine are controlled by pressure development during combustion and inertia forces due to rotating and reciprocating masses. Figure (10) shows pressure diagrams for direct injection engines with and without turbocharging.

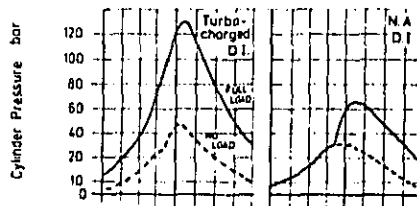

Figure 10. Comparison of pressure development during combustion in Direct injection (D.I.) diesel engines. From [11]  
N.A. = Naturally Aspirated.

For a loaded engine the pressure development in a turbocharged engine is much smoother than for a N.A. engine and therefore excitation due to combustion less. Without load the difference is negligible. A turbocharged engine also has to withstand higher pressure forces and needs stronger pistons, gudgeon pins and connecting rods. This requires more reciprocating mass and thus may lead to increased noise.

A small Stroke/Bore ratio will also give smaller reciprocating forces for a given engine speed.

It may therefore be expected that these engines might be more noisy than the two turbocharged engines in the group when loaded.

The engines in this group were all of a rather conventional design and there is little correlation between the small variations in their designs and the noise output.



Figure 11.

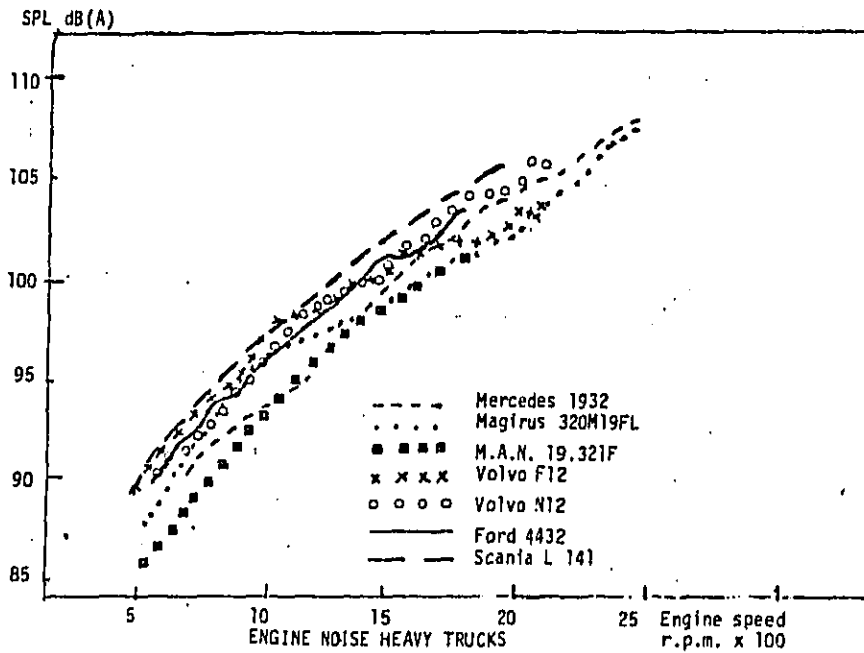
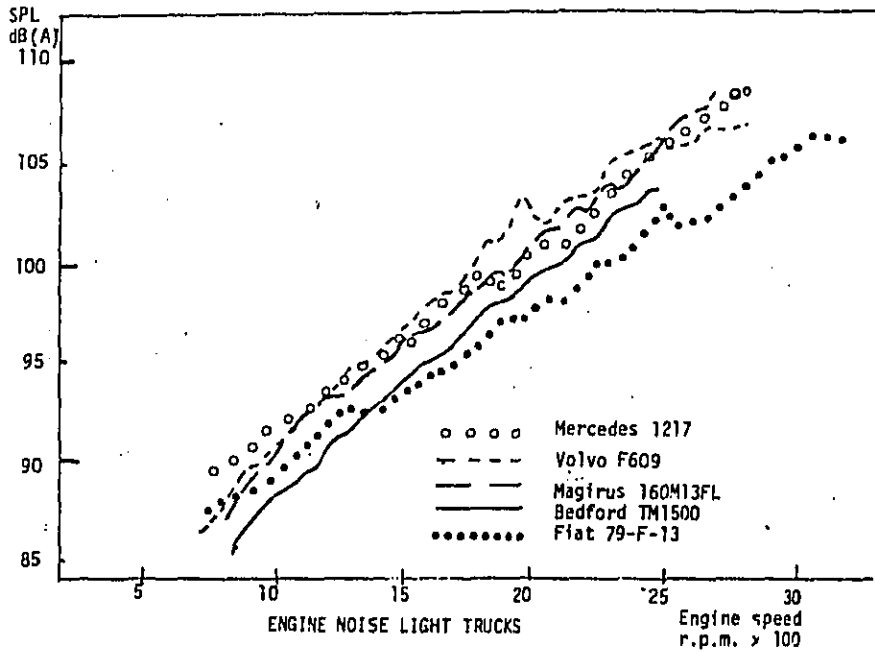

Heavy Trucks

The M.A.N. 19.321F had the lowest engine noise level in this group. The engine had an advanced induction system incorporating turbocharging, intercooling and resonant induction. When the charge air is compressed by the turbo the temperature rises to 120°C, the intercooler is a radiator cooling the air down to 50°C and thus increases the density. Resonant induction utilizes the pressure drop when the air is inducted to a cylinder to set up standing waves in the manifold, with such a frequency that the air pressure will be at peak at a valve everytime the valve opens for a certain engine speed. Such a system ensures that the charge air will be dense and at a controlled low temperature for a wide range of engine speeds. The pressure rise in the cylinders will therefore be smooth and noise due to combustion kept low.

The system also have other advantages, such as low specific fuel consumption, clean exhaust, maximum power output at low engine speed and a flat torque curve. The two last points are important for noise emission during everyday operation of the vehicle. It can more easily be driven at low engine speeds, where it will emit less noise.

Magirus 320M19FL and Mercedes 1932 both had a low noise level at low and medium engine speeds, but achieved their maximum power at higher speeds than the other vehicles. The engines of these trucks have much in common, similar dimensions, configuration and neither were turbocharged. However, the Magirus engine was air cooled, while Mercedes used water cooling.

To allow for the missing effect of turbocharging they utilize swirl induction. This means that the inlet and combustion chamber is designed such that the air is set into rotation when drawn into the cylinders. The fuel will then mix more uniformly with the air when injected and the pressure rise will be smoother. The system is shown in figure (12).

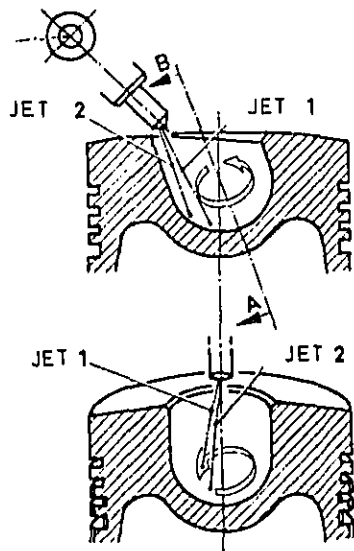

SECTION A-B  
- FL 413 F combustion chamber and position of the injection jets

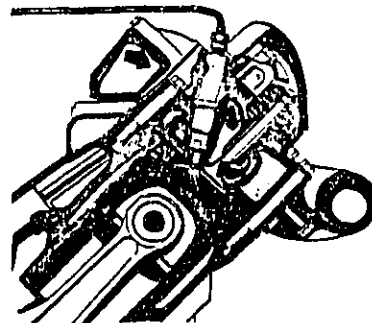

Mercedes Inlet  
From [13]

From [12]

Figure 12. Swirl Induction.

The system does not fully compensate for the power and torque gained by turbocharging so larger displacement and higher engine speeds has to be utilized.

Magirus [12] states that they also have reinforced the crankcase, enlarged the main bearing diameter, used cast aluminium valve covers and strengthened the exhaust manifold to reduce the noise output of the engine.

There was less vibration in the lower parts of the engines in this group than for the light trucks. This indicates that the manufactures are consious of the problem of crankcase/ oil pan vibration and have attempted to improve the structures. Especially Ford and Scania proved to have a low level of oil pan vibrations. Cummins [14] has developed a finite element model

of the Ford engine block and verified it experimentally. This model is used for structural improvements and they have particularly concentrated on the lower parts of the engine.

### 7.2. Exhaust Noise

The exhaust is a potentially strong noise source, but can be reduced to an acceptable level by proper exhaust system design. The exhaust system design is the most important parameter controlling the actual exhaust noise level emitted from a vehicle, although engine design parameters are important as well. Valve size and camshaft configuration determine the sharpness of the exhaust pulses. Injection timing is important for the cylinder pressure and hence the magnitude of the pulse noise. The exhaust manifold can be designed to obtain maximum pulse cancellation for a multicylinder engine. Turbocharging reduces the exhaust noise straight from the engine with approximately 10 dB(A), but increases the flow and hence the problem with flow noise and backpressure in an exhaust system [15].

From the results in figure (13), it is clear that the exhaust system design completely dominates over all engine design features, apart from size. The light trucks have less gas flow through their engines and thus demand less from their exhaust systems.

All the vehicles had exhaust systems consisting of piping and one single reactive muffler. The effect of such a system depends upon the dimensions and positions of the various components, structural strength and on tightness. The spread of the results witnesses large variation in system quality. The maximum difference for a given engine speed is 19 dB(A), while the variation in level is between 8 and 12 dB(A) for the light trucks and from 5 to 11 dB(A) for the heavy trucks.

The average increase in A-weighted noise level versus engine speed is approximately 10 dB pr. 1000 RPM.

Figure 13.

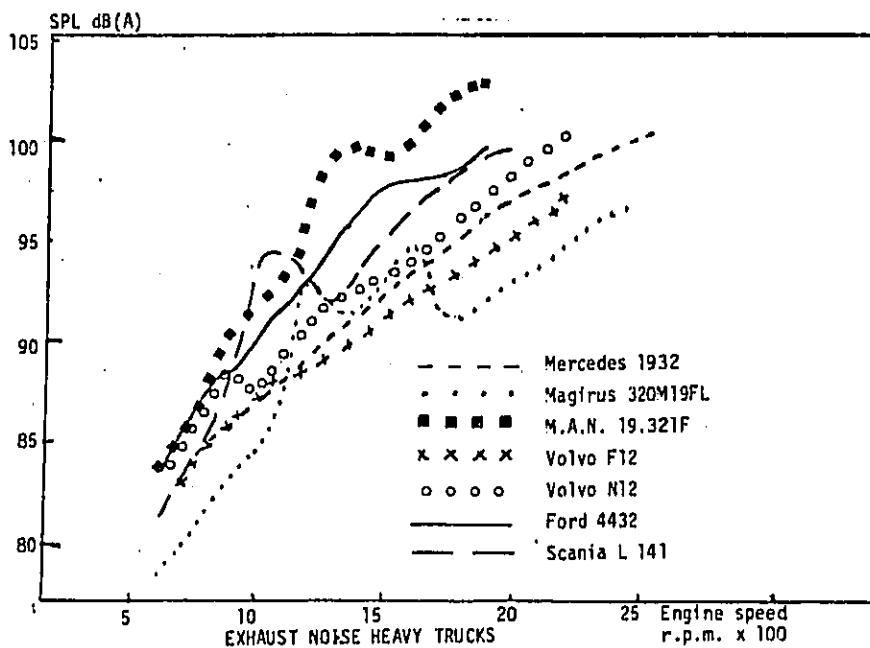
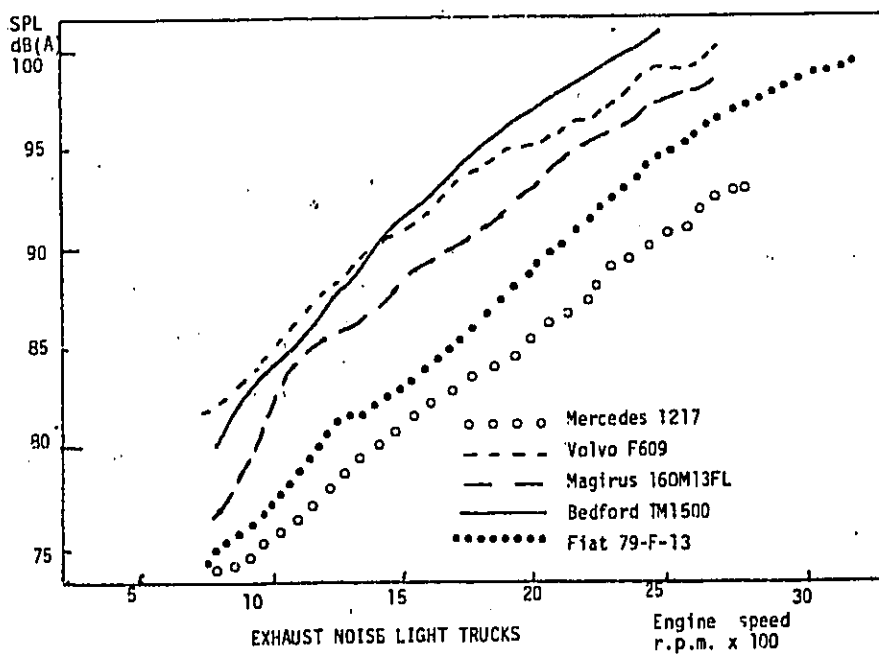

### Light Trucks

Mercedes 1217 emits the lowest level. The vehicle is equipped with a well designed conventional exhaust system and is turbo-charged.

### Heavy Trucks

The exhaust system of Magirus 230M19FL performed well at low and high engine speeds, but had a strong whistle tone at 3300 Hz between 1200 and 1700 RPM. Such a tone can be caused by vortex shedding due to a flow disturbance in the system, e.g. an elbow.

Several other systems in this group had "break down" at certain engine speeds either due to regeneration of noise or breakdown of the acoustic properties of the system due to standing waves. The heavy flow of gas through the systems in this group does obviously create problems for the system designer.

Volvo F12 seems to have the best overall system. Volvo uses the "cut and try" method to design their exhaust systems, they have not obtained satisfactorily results from theoretical calculations alone [16].

### 7.3. Air Intake Noise

The air intake noise was the least important of the four noise sources at which near field measurements were carried out. Only for a couple of the vehicles did the air intake noise contribute significantly to the A-weighted noise at the reference position. The low frequency content of the noise, due to intake pulses, dominates.

Intake noise is reduced in the same way as exhaust noise, with a reactive muffler. The muffler usually serve as a container for the air filter as well. The end of the intake pipe may be positioned above the roof of the cabin, in the vehicle front panel or simply anywhere around the vehicle. Intake noise is

regarded as easier to silence than exhaust noise due to smaller amplitude of the pulse noise and less flow.

Figur (14) displays the results for all the vehicles. Again, the design of the silencer system seems to dominate over other parameters. The difference between the least and most noisy vehicles varied from 10 to 17 dB(A) depending on engine speed.

Two of the heavy trucks have the lowest level of all the vehicles.

Most of the vehicles have fluctuations in the noise level as the engine speed changes. This is due to standing waves in the systems breaking down the acoustic properties. These fluctuations are negligible in most cases and the manufacturers may have chosen a cheap and simple system design disregarding the effect of standing waves.

Scania L141 and M.A.N. 19.321F emitted the lowest intake noise levels. Both used the air filter container as the only muffler in the intake system. Scania had the air intake above the cabin roof, M.A.N. in the right hand corner of the front panel.

The difference between the Mercedes 1932 and Magirus 320M19FL with almost similar engines, but different intake systems illustrates the importance of silencer design.

Figure 14.

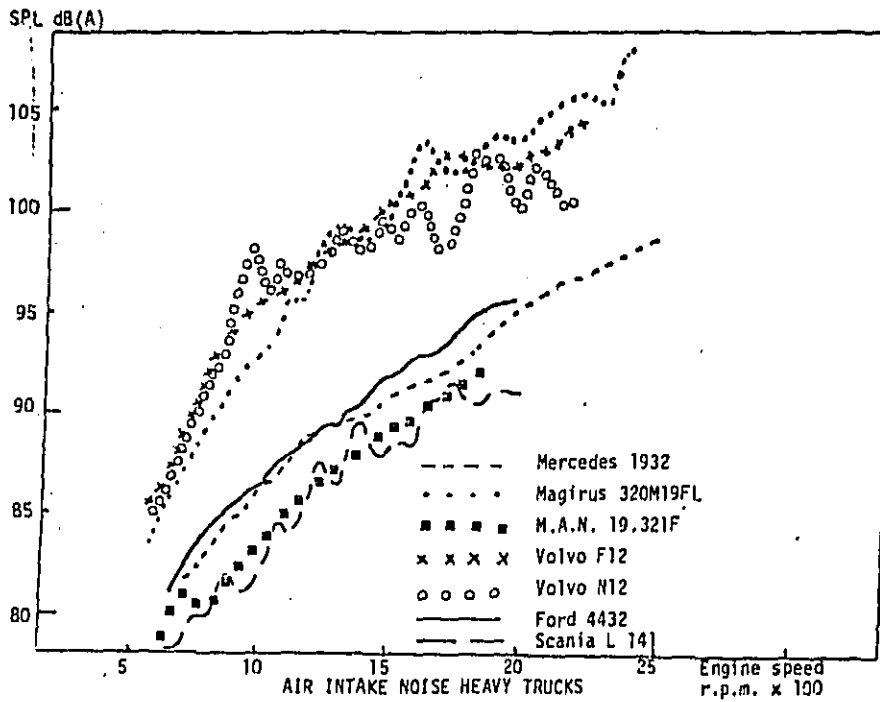
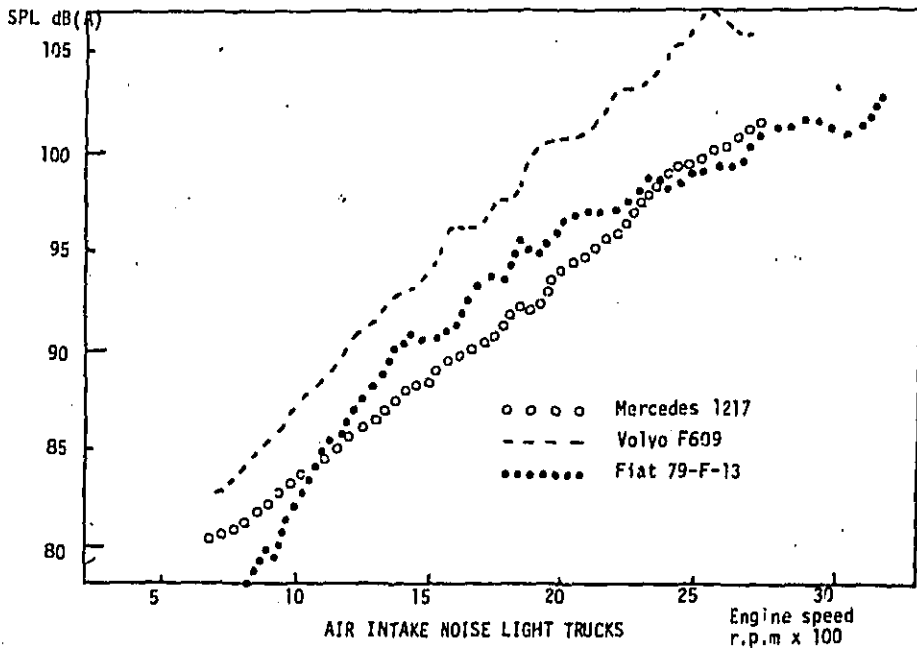



#### 7.4. Radiator Noise

As explained previously, "radiator noise" is measured in front of the vehicle. Three factors influence the noise registered in this position: The noise level of the cooling fan, forward radiated engine noise and the degree of reverberant build up in the engine compartment.

M.A.N. 19.321.F has got the lowest noise level in this position. It is 10-12 dB(A) below the most noisy vehicle for a given engine speed, see figure (15).

The light trucks achieves the highest noise levels due to their high engine speeds at maximum power.

The average increase in A-weighted noise level is 10 dB pr. 1000 RPM.

Most of the vehicles had temperature controlled fans, which will only run for a limited periode of engine operation and not during drive past tests.

#### Light Trucks

Fiat has the lowest noise level for a given engine speed, Bedford the highest. For both vehicles the fanblade passage frequencies are visible in the spectra, indicating that improvement of the fan designs could reduce the noise emission.

#### Heavy Trucks

The arrangement of M.A.N.'s cabin was rather special. The space between engine and cabin was large and the underside of the cabin was fitted with a flexible mat. It had no restrictions on the side of the engine, apart from the wheels. This may have kept forward reflections from top and sides of the engine at a low level and thus be the reason for the good result. Still, the fan does emit some noise at it's blade passage frequencies which could have been avoided.

Figure 15.

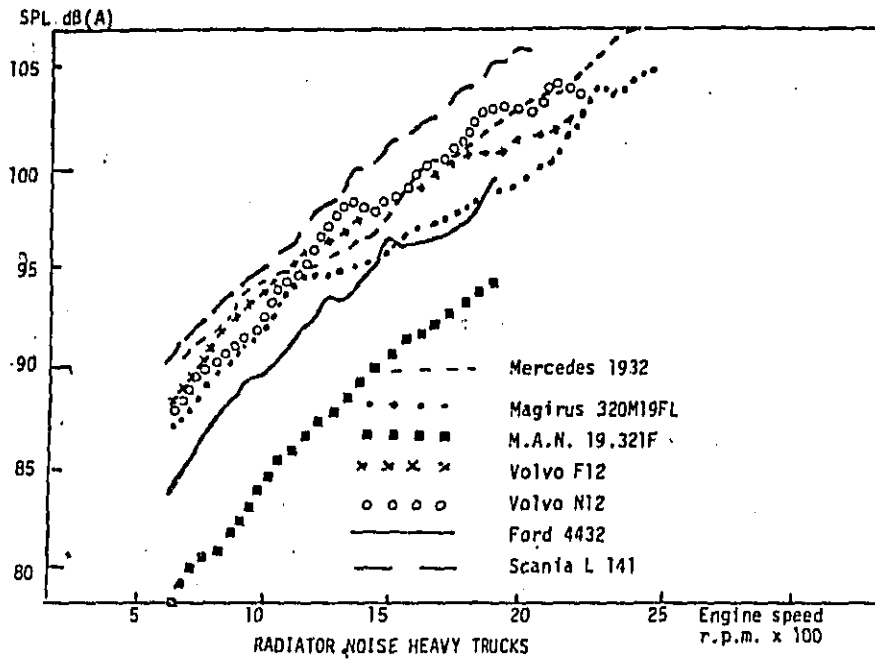
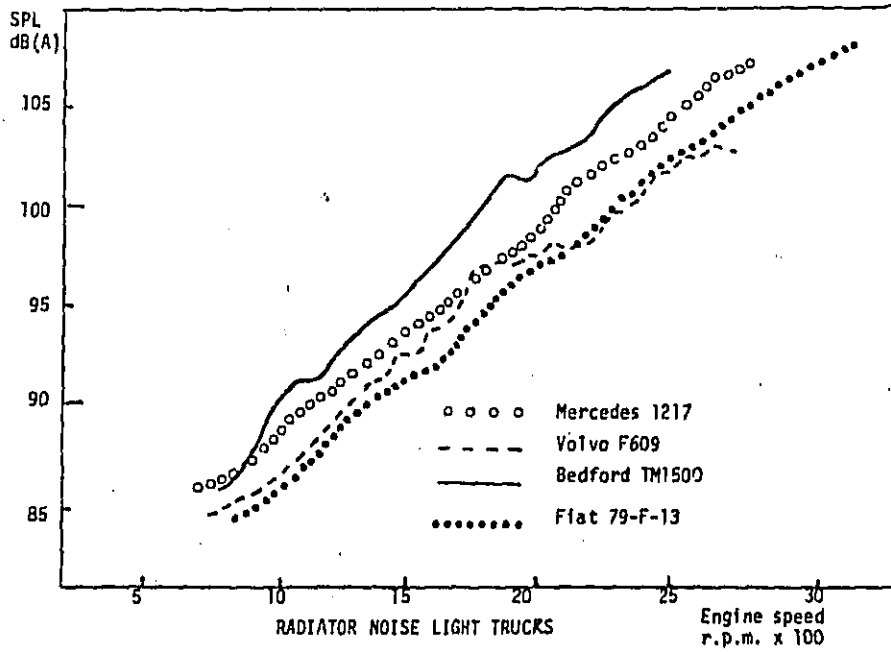

Ford is also relatively quiet, but for this vehicle the engine noise dominates. Besides the engine there were some undamped metal plates fitted to the cabin. These may have caused a reverberant build-up and lead to engine noise radiation out of the front.

Scania had a high noise level in front of it's radiator. From the spectrum, it is obvious that this is mainly due to the fan.

#### 7.5. Reference Position

Noise in the reference position represents the sum of all the sources on a vehicle. The reference position was 15 m from the vehicle side, if one assumes that the vehicle is a simple point source the level at 7,5 m will be 6 dB(A) higher.

The light trucks were generally less noisy than the heavy trucks for a given engine speed, but at maximum power they were just as noisy as the heavier vehicles, figure (16). The engines were not as advanced as the bigger engines and achieved their maximum power at high engine speeds. These vehicles will often be driven in discontinuous traffic where they will need to accelerate to maximum engine speed to keep up with other traffic. Their torque curves are relatively flat, figure (8), so there is little incentive in driving at low engine speed.

The maximum difference in noise level at a given engine speed was 13 dB(A) while it varied between 3 and 6 dB(A) for the light trucks and between 5 and 8 dB(A) for the heavy trucks.

The A-weighted noise level increased approximately 10 dB(A) pr. 1000 RPM.

Most of the vehicles had one or two sources which dominated the noise emission.

Figure 16.

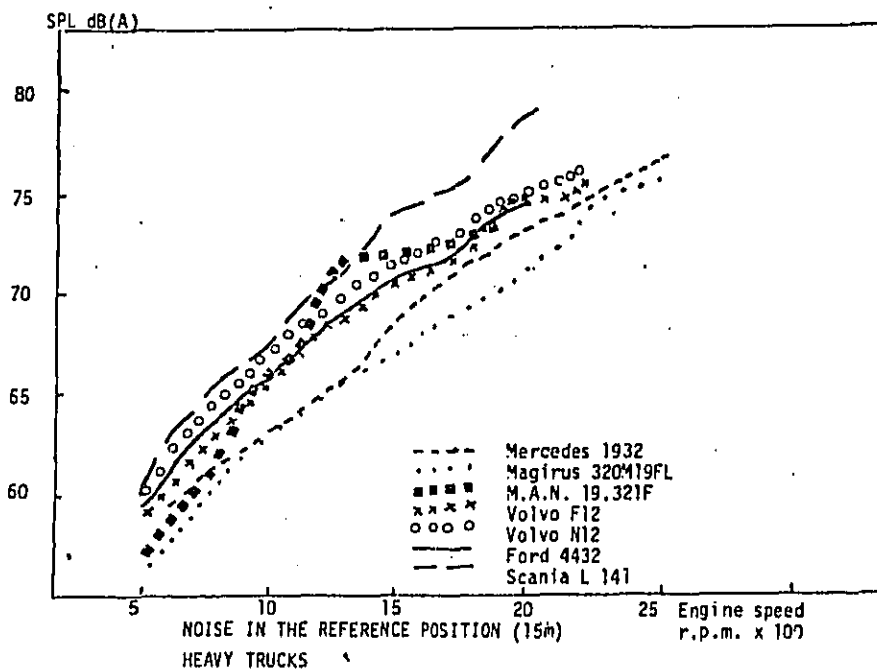
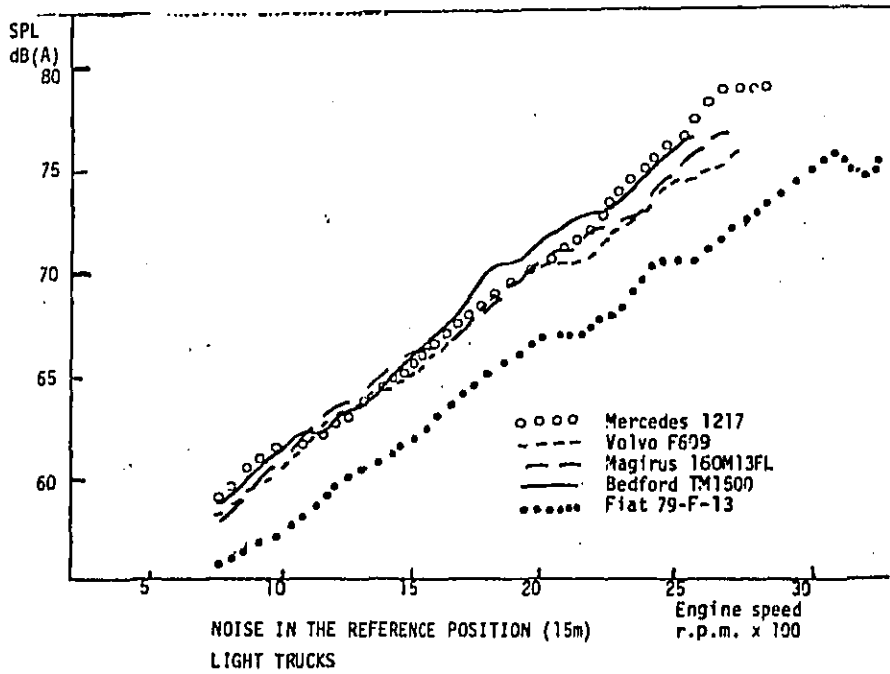

Light Trucks

Fiat 79-F-13 was 3-4 dB(A) below the next vehicle at a given engine speed. The engine noise was fairly low although the engine is of a conventional design without turbocharging. The other sources were all well silenced giving an overall quiet vehicle.

Heavy Trucks

In this group Magirus 320M19FL came best out for a given engine speed. As explained previously, several improvements have been carried out on its engine to bring the noise down. It had a very noisy air intake which easily could be controlled and brought the level in the reference position down 1 dB(A).

M.A.N. which had very low levels of engine, radiator and intake noise, had a dominating exhaust which is responsible for the high level at the reference position. With a better exhaust system, the noise emission would be reduced significantly. However, with its low engine speed, this vehicle had the lowest noise level in the series at maximum power.

Comparison with Near Field Measurements

To check the accuracy of the near field measurements and to assess the influence of each source on the noise at the reference position, the near field results for maximum engine speed were corrected for distance and summated. This is done using the following expression, assuming all sources to be point sources at set distance from the microphone:

$$- 20 \log \left( \frac{\text{Dist}}{\text{Ref}} \right)$$

where

Dist = Distance from source to reference position

Ref = Distance between source and microphone

Table 3. Comparison of corrected near field levels with level in reference position.  
 (maximum engine speed)

Vehicle	A Engine dB(A)	B Exhaust dB(A)	C Air Intake dB(A)	D Radiator dB(A)	A+B+C+D dB(A)	Measured 15 m dB(A)	Difference dB(A)	Measured+6 dB ≡ level at 7,5 m
Bedford TM1500	70,5	71,1	—	71,2	75,7	76	- 0,3	82
Fiat 79-F-13	72,5	69,1	65,0	72,2	76,6	75	+ 1,6	81
Vagirus 160	74,5	68,1	—	—	75,4	77	- 1,6	83
Mercedes 1217	74,5	63,1	63,5	72,2	76,9	79	- 2,1	85
Volvo F609	72,5	70,1	68,5	68,2	76,1	77	- 0,8	83
Ford 4432	70,5	70,1	57,5	65,2	74	75	- 1	81
Vagirus 320	73,5	67,1	70,0	69,2	76,6	75	+ 1,6	81
L.A.N. 19.321	67,5	73,1	53,5	59,2	74,3	73	+ 1,3	79
Mercedes 1932	74,5	70,1	60,5	72,2	77,4	77	+ 0,4	83
Fiat L141	73,5	70,1	52,5	71,2	76,7	80	- 3,3	86
Volvo F12	70,5	68,1	65,5	68,2	74,4	75	- 0,6	81
Volvo N12	73,5	70,1	63,5	69,2	76,3	76	+ 0,3	82

### 7.6. Rolling Noise

Table (4) displays the results from the rolling noise measurements together with relevant technical data for the vehicles. The vehicles are tabulated in inverse order of noisyness. Rolling noise was not measured on the Volvo F609.

Several factors affect truck rolling noise generation. Tyre noise depends upon tread design, road surface, wear, speed, inflation pressure and load [17]. Aerodynamic body noise depends mainly upon vehicle speed and body configuration.

The aim of this investigation was to establish the significance of rolling noise compared to power unit noise. As measurements were carried out for only one type of tyre for each vehicle, the influence of the above factors could not be established. However, the results indicate that vehicle weight and speed are major parameters.

If the results are compared with the results for the power unit noise sources at 7,5 m (table 3), it can be seen that the rolling noise is significant at 70 km/h even if the power unit noise sources dominate. If, however, the power unit noise sources are attenuated slightly the rolling noise may represent a "noise reduction roof". At lower speeds, such as those achieved during drive past tests, the rolling noise will be insignificant even after considerable attenuation of the power unit noise sources.

Table 4. Rolling Noise.

Vehicle	Tyres Dimensions and make	Chassis weight (kg)	Gross vehicle weight (kg)	Number of wheels	Sound pressure level at 7,5 m dB(A)	
					50 km/h	70 km/h
Fiat 79-F-13	8,5 R 17,5 MICHELIN	3120	8000	6	70	75
Mercedes 1217	10 R 22,5 MICHELIN*	4400	13000	6	70	76
Magirus 160 M13P1	10 R 22,5 MICHELIN	3860	12000	6	72	76
Scania L141	11 R 20 MICHELIN	8215	23000	4**	72	76,5
Bedford TM1500	11 R 22,5 MICHELIN	4800	15000	6	73	—
M.A.N. 19.321F	12 R 22,5 MICHELIN XZY	6700	17500	4**	73,5	77,5
Volvo F12	Front 13 R 22,5 CONTINENTAL Rear 12 R 22,5	8300	23500	6***	75	77,5
Magirus 320M19K1	13 R 22,5 PIRELLI	6980	16800	6	76	78
Volvo N12	11 R 20 MICHELIN*	7600	23000	10	75	79
Mercedes 1932	Front 13 R 22,5 CONTINENTAL Rear 12 R 22,5 MICHELIN	6700	17000	6***	76,5	79
Ford 4432	Front 315/75x22,5 Rear 315/70x22,5 MICHELIN*	6910	17000	6	75	80

- \* Summer tyres on the front wheels, winter tyres on the rear wheels.
- \*\* Only two wheels mounted on the rear axle, should have been 4.
- \*\*\* Boggy axle lifted.

The rolling noise varied from 70 to 76,5 dB(A) at 50 km/h and from 75 to 80 dB(A) at 70 km/h.



### 7.7. Cabin Noise

A commercial vehicle is often driven 6-12 hours a day by the same driver. A low noise level inside the cabin is important to avoid hearing damage, annoyance and fatigue for the driver. All the vehicles were well below the danger level for hearing damage, which is dependent on the A-weighted noise level and time of exposure.

The linear levels, however, were very high, varying from 80 to 96 dB. The shaded areas in figures (17 and 18) are drawn between the upper and lower level registered in each group. The levels fluctuate strongly for all the vehicles and for clarity only the boundaries are indicated. Figure (19) shows three different versions of the spectrum from two of the cabins. From the linear spectra it can be seen that the major contribution to the linear noise level is below 200 Hz and occurs at discrete frequencies equal to half the engine resolution frequency. (i.e. the firing frequency for each cylinder). This is due to noise being transmitted from the engine through the cabin floor and because engine vibrations transmitted to the cabin is radiated as noise from walls and windows. A cabin has usually got a rectangular shape with a maximum dimension around 2 meter. Thus room modes (resonances in the air) will occur from 85 Hz and upwards. The reason for the strong fluctuation in linear level is that one or most of the discrete frequency. Components coincide with room modes as the engine speed changes and is more or less amplified.

The low frequency noise will not cause hearing damage, but little is known about other possible consequences, e.g. fatigue, annoyance, motion sickness etc.

All partitions and absorption materials are strongly frequency dependent and lose much of their effect at low frequencies. Hence the problem is hard to avoid with conventional sound control methods. Due to the discrete harmonic character of the noise, active noise cancellation methods may be a feasible solution.

## **ELAB** AKUSTISK LABORATORIUM

While all the vehicles had linear noise levels fluctuating randomly around approximately the same average level, the A-weighted results show large variations between the different vehicles. The difference between the least and most noisy cabin being around 10 dB(A). The difference in results are mainly due to varying sound insulation of the cabins, even if engine noisiness also will influence.

There is no average difference between the heavy and the light truck group, which indicates better sound insulation of the heavy trucks as these had generally noisier engines. The size of the cabin may also influence. A large cabin may be fitted with more absorption material than a small one.

The average increase in A-weighted noise level is 9 dB/1000 RPM. This is slightly less than for the noise sources and is due to the insulating properties of a cabin being more efficient as the frequency of the noise increases.

### Light Trucks

Four of the vehicles had approximately equal noise levels in their cabins, while the Fiat 79-F-13 was 4-6 dB(A) below them.

Fiat had a sound deadening compound smeared on the cabin plates above the engine. The inside of the cabin had complete lining of the ceiling, side and rear panels with sound-proofing material. The floor was covered with sound-deadening multilayer carpeting. The engine was less noisy than most of the other engines.

### Heavy Trucks

M.A.N. had a remarkably quiet cabin. The space between the bottom of the cabin and the engine was large. The underside of the cabin was clad with a flexible metal mat. Inside, the cabin was well fitted with absorption materials and the floor had a thick multilayer carpet. The engine had a low noise level.

Figure 17.

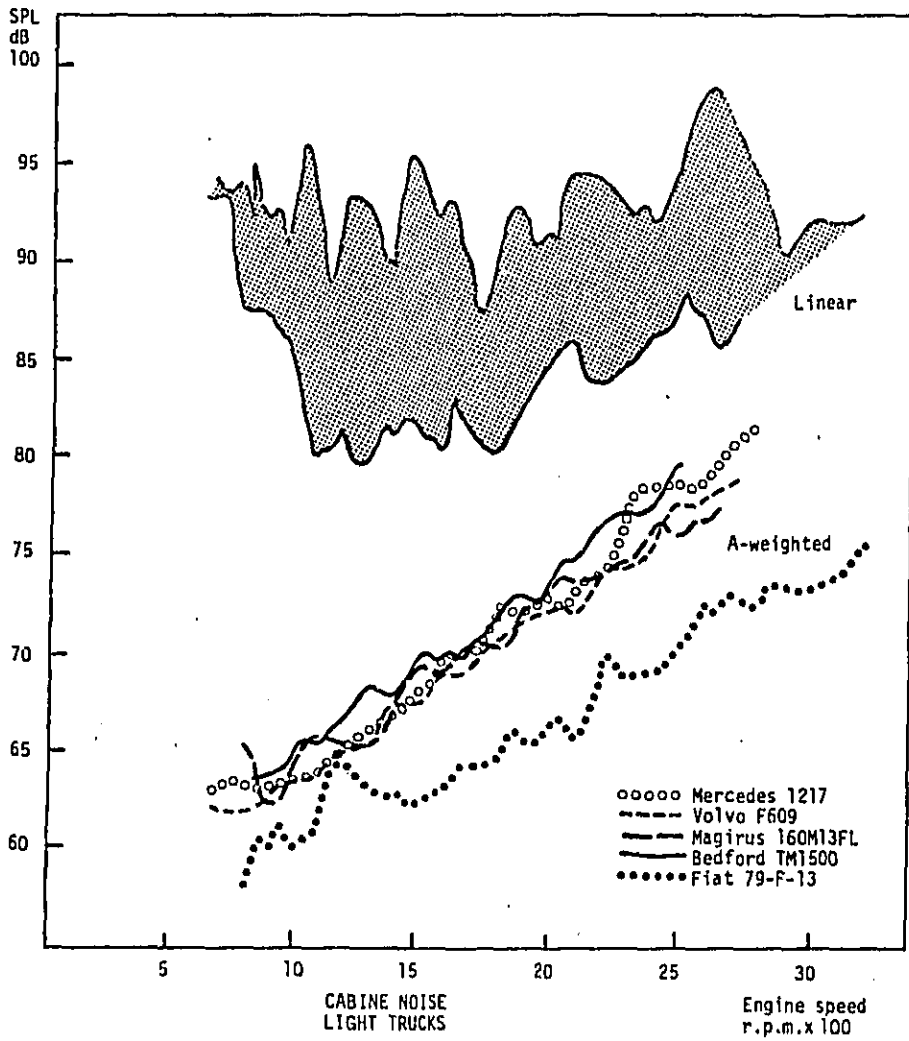

Figure 18.

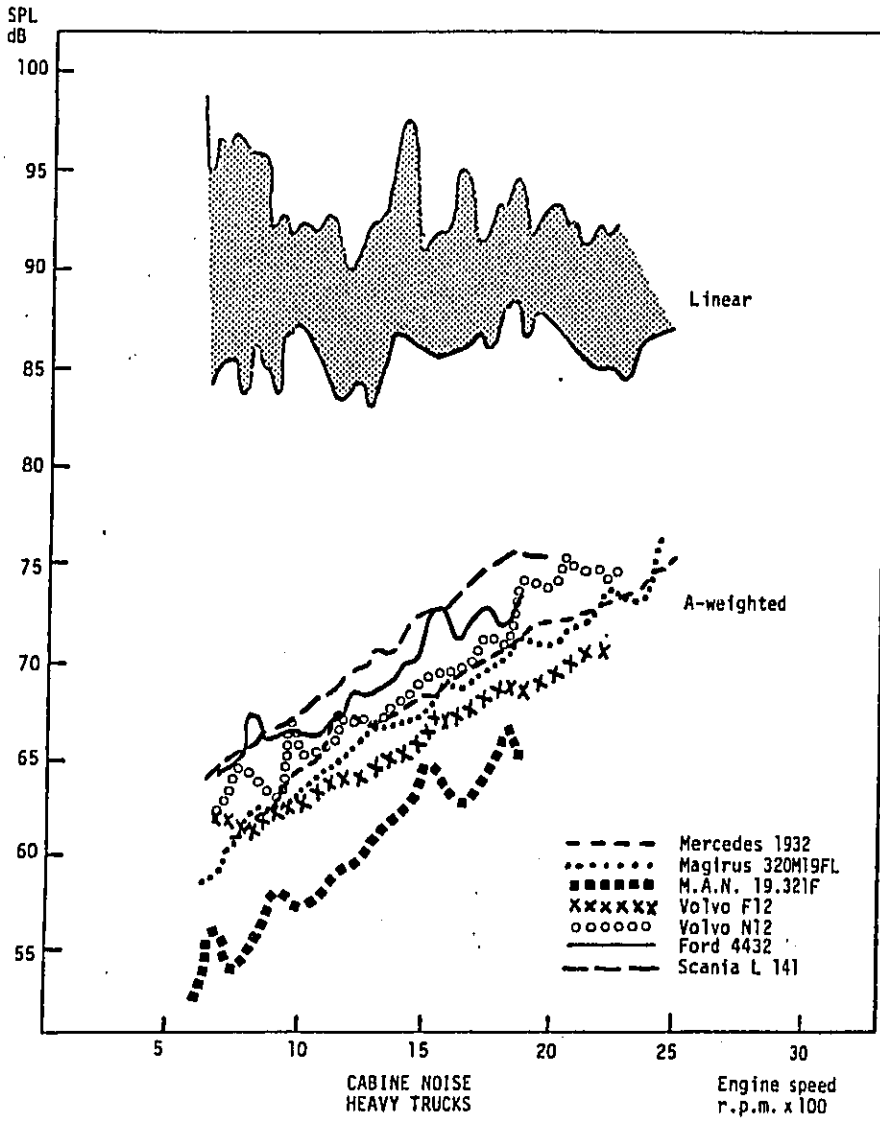
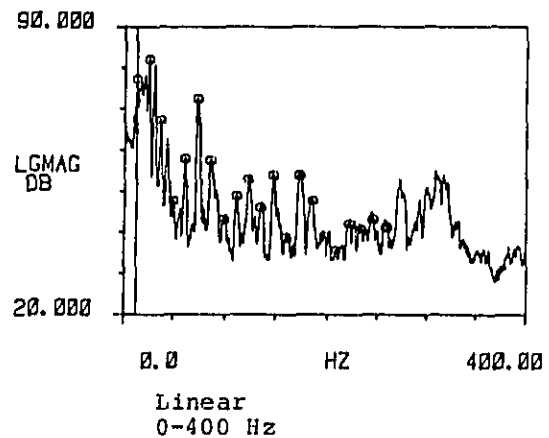
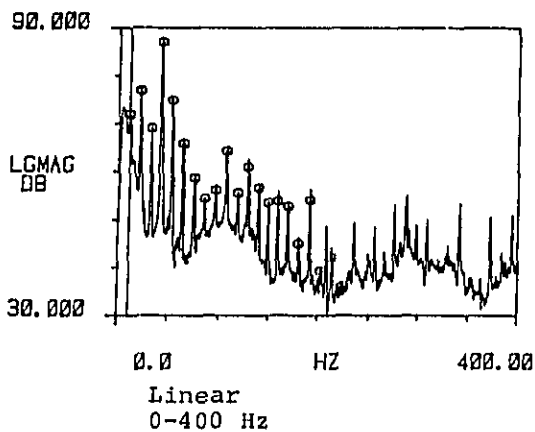
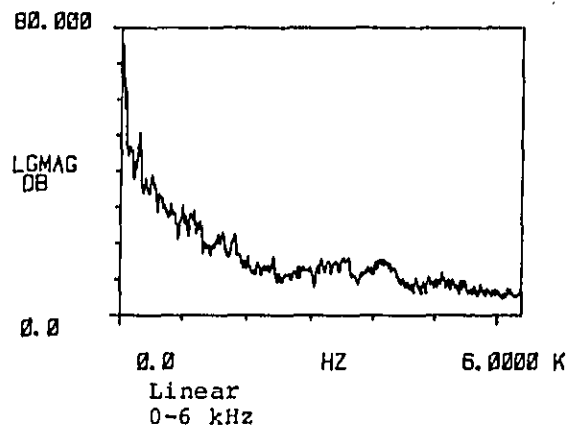
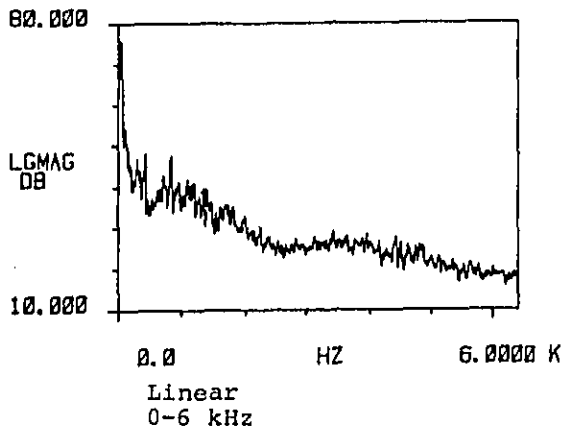
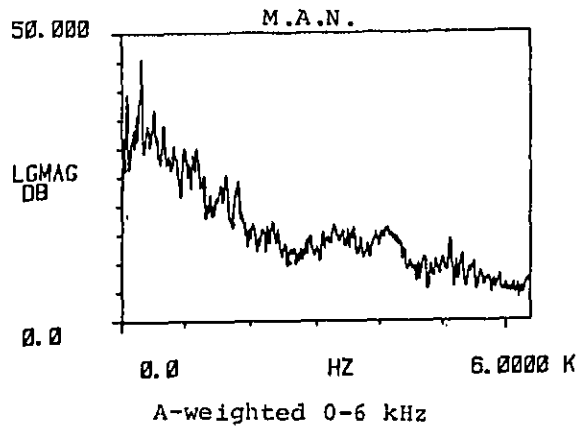
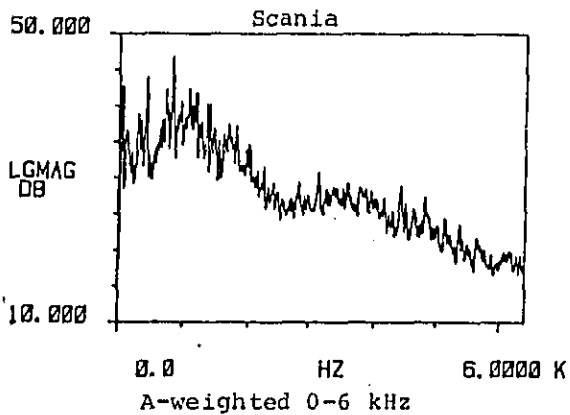

Figure 19. CABIN NOISE SPECTRA



Volvo F12 was also relatively quiet. The cabin was well fitted with absorption materials, but had a more noisy engine than the M.A.N.

The two normal control trucks were fairly noisy. The engine is fitted in front of the cabin in such a vehicle, so they ought to be easier to insulate against direct transmission of engine noise. On the other hand the cabins are less roomy and do not have berths. Scania have now introduced a new model which they claim to be 3 dB(A) less noisy than the model tested here [9].

## 8. NOISE REDUCTION

### 8.1. Possible Noise Reduction with Present Technology

The Norwegian noise emission limit for trucks with g.v.w. above 3500 kg is 89 db(A) or 91 dB(A) if the engine performance exceeds 147 kW, measured according to ISO IS 362. A recent investigation [18 and 19] proposed a reduction of the limit to 86 dB(A) or 88 dB(A) if the engine performance exceeds 147 kW, and to set a future target of 80 dB(A) independent of engine performance. Other European countries have approximately similar regulations and plans for future regulations.

Results of the type presented here can not be related directly to ISO IS 362 results. On the other hand a quantitative forecast of possible noise reduction by optimal use of present technology can be made and related to previously published drive past results, see figure (21).

This investigation has revealed a large spread in results for the various sources. It is also clear that most of the vehicles had one or two sources which were particularly noisy. By combining the best results for the various sources and correcting them for distance one can get an indication of the noise reduction that may be achieved by optimal use of present technology. In table 5 such combinations have been made for the light and heavy trucks. The engine speeds for the "optimal vehicle" is the average of the engine speeds of the results it consists of.

The results from table 5 have been plotted together with the measured results in figure (20). As can be seen, Fiat resembles the "optimal vehicle" in it's group for a given engine speed, but has a higher maximum level. The "optimal vehicle" is generally 3 to 5 dB(A) below the average level for the group. For the heavy trucks the "optimal vehicle" is below any of the other results and 8 to 5 dB(A) below the average of the group. Here the "optimal vehicle" indicates the level the M.A.N. could achieve with a better exhaust system.

Table 5. Combination of best results for the major sources to an optimal vehicle.  
(All results are in dB(A)).

	ENGINE			EXHAUST			AIR INTAKE			RADIATOR			OPTIMAL VEHICLE		
Vehicle	BEDFORD			MERCEDES 1217			MERCEDES 1217			VOLVO F609			COMBINED LEVEL AT 15 m		
	IDLE	S/2	MAX	IDLE	S/2	MAX	IDLE	S/2	MAX	IDLE	S/2	MAX	IDLE	S/2	MAX
Results dB(A)	84	93	102	74	83	93	80	90	102	84	94	102			
Corrected results dB(A)	52,5	61,5	70,5	44,1	53,1	63,1	41,5	51,5	63,5	49,2	59,2	67,2	54,8	64,1	73,2
Vehicle	M.A.N.			MAGIRUS 320			SCANIA L141			M.A.N.			COMBINED LEVEL AT 15 m		
	IDLE	S/2	MAX	IDLE	S/2	MAX	IDLE	S/2	MAX	IDLE	S/2	MAX	IDLE	S/2	MAX
Results dB(A)	84	94	99	77	96	97	78	87	91	78	88	94			
Corrected results dB(A)	52,5	62,5	67,5	47,1	66,1	67,1	39,5	48,5	52,5	43,2	53,2	59,2	54,1	67,9	70,7

Correction factors are stated in chapter 7.5.



Figure 20.

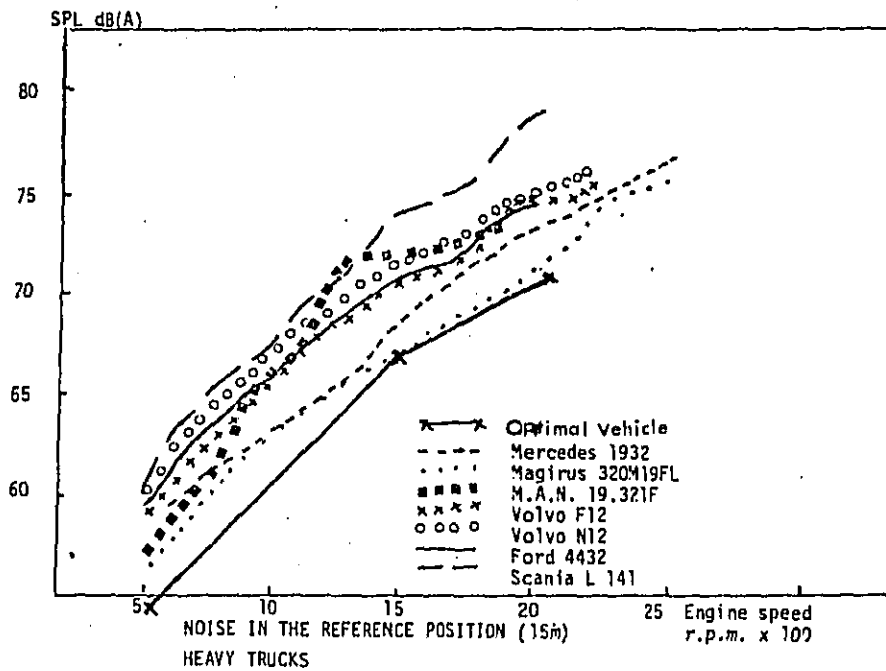
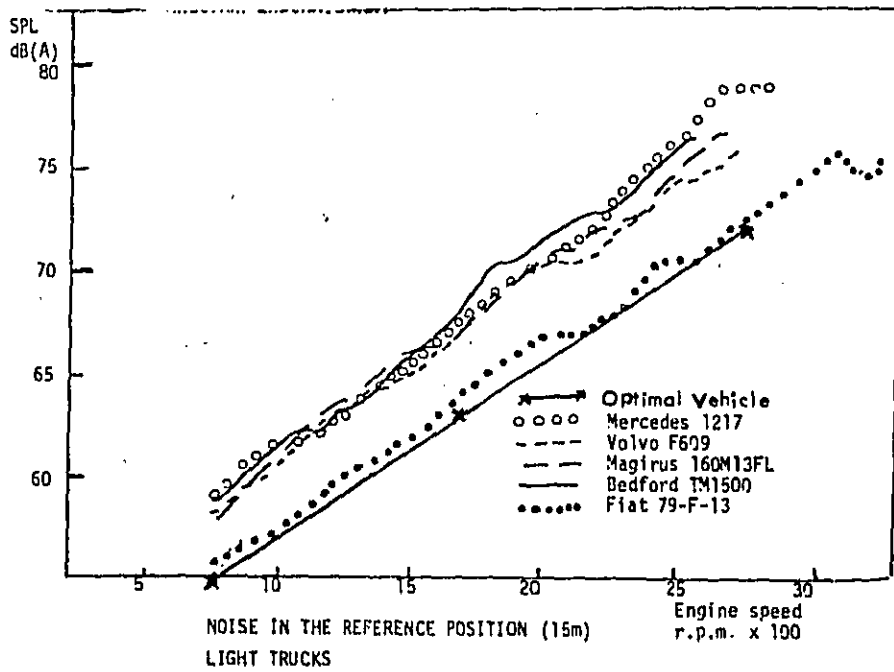
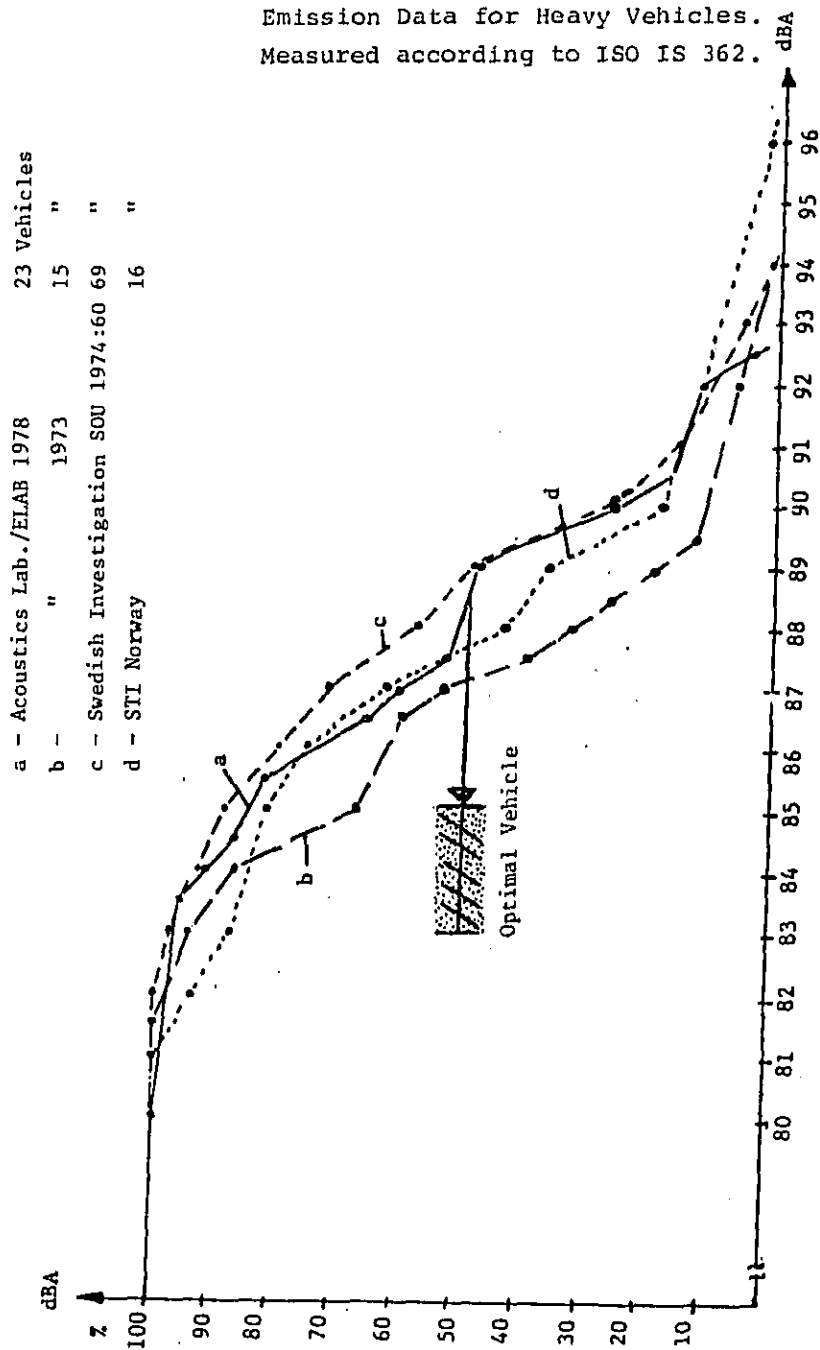

Figure 21. Cumulative Distribution of Noise Emission Data for Heavy Vehicles. Measured according to ISO IS 362.



The shaded area in figure 21 indicates the drive part result the average vehicle could achieve by more careful design, i.e. 83-85 dB(A).

### 8.2. Further Noise Reduction

To achieve further noise reduction below 83 to 85 dB(A) (ISO IS 362), more involved noise control work has to be performed. This may include, structural optimization of the engine, use of low noise combustion system, shielding of the engine or enclosing it completely, improvement of the exhaust and intake system, improvement of the fan and reduction of the rolling noise. Much literature exists on different noise control techniques for trucks e.g. [20 to 23]. However, further noise reduction does not only depend upon knowledge of the right noise control method, but other factors such as fuel consumption, engine life, smoke emission, serviceability and economy become increasingly important and must be taken into account. It is therefore more interesting to consider complete solutions rather than solution for separate noise sources.

Several low noise prototypes have been buildt. TRRL\* and other research establishments in Britain have since 1971 worked on a quiet heavy vehicle project. They have now made a demonstration vehicle built to production standard that will satisfy a 80 dB(A) noise limit [24 to 26].

The vehicle is a Foden tractor unit with a 262 kW Rolls Royce engine. To achieve the low noise level the engine structure was completely revised and a structural enclosure around engine and gearbox incorporated into the design. Thirdly, the cooling system is totally ducted and employs a mixed-flow fan and finally the exhaust system was redesigned. It is expected that the additional cost of the vehicle in production would be 8-10%,

---

\* TRRL - Transport and Road Research Laboratory

with a negligible change in maintenance cost.

A weight penalty of 0,8% is expected for a complete articulated vehicle. Factory retooling is expected to take three years, before production of the vehicle would be possible.

The TRRL project has also included a Leyland Buffalo vehicle with a 158 kW engine. The vehicle does meet a 80 dB(A) noise limit but is not suited for production.

Klöckner-Humboldt-Deutz and Magirus Deutz [12] has experimented with further noise reduction on their air cooled V8 engine which develops 188 kW. The engine comes from the same series as the V10 engine tested in this project. When fitted in a vehicle, they found it quite feasible to reduce the noise level to 82 dB(A) during drive past tests. This was achieved by retarding the injection 2 degrees, applying damping treatment to the oil pan and the intake manifold, reconstructing the cooling fan, increasing the muffler volume, optimizing the intake pipe lengths and by shielding the engine. It was calculated that the cost of all these improvements would amount to approximately 2 to 3% of the vehicle price.

The same companies in cooperation with the University of Stuttgart have also developed a quiet prototype of a smaller truck [27]. The truck has a g.v.w. of 7500 kg and a 6,2 l engine developing 96 kW. This vehicle has a drive part noise level of 77 dB(A) and is now fully suitable for series production. The low noise level has been achieved by fitting a turbo, reducing the engine speed and similar measures as those used for the bigger vehicle. The German post office is going to use 50 of these vehicles as a trial this year.

The increased cost is estimated to 8,5% of the vehicle price and the weight has increased 120 kg.

### 8.3. Noise Emission Forecast

As indicated by the results, it is possible to construct vehicles with drive past levels as low as 83 to 85 dB(A) if proper care is taken in designing engine structure, induction system, combustion system, fan and exhaust system. Little effort would be required from most manufacturers to achieve such levels, because only one or a couple of the above factors would have to be considered for most vehicles.

The light trucks have greater noise reduction potentials, as they were of generally less advanced design. By introducing or increasing the turbocharging and keeping the maximum power output constant, the engine speed could be reduced. This would reduce the noise output substantially and might also lead to improved fuel consumption.

To carry out such improvements the manufacturers need the stimulus of reduced noise emission limits. Negligible effort and cost would be involved in meeting the proposed limits of 86 respectively 88 dB(A) for the two groups. By giving the producers a couple of years to cope with the inertia of design changes a limit of 83-85 dB(A) could be introduced. Due to the greater reduction potential of the light trucks, a differentiated limit for the two groups is appropriate also in the near future.

As has been shown in several research projects it is fully feasible to construct trucks with noise levels below 80 dB(A) today. This would require more involved noise control effort from the manufacturers, increase the cost of the vehicle by up to 10% and give a slight increase in vehicle weight. Most European countries have heavy and often progressive taxation on vehicles. If documented noise control cost was exempted from such tax a noise controlled vehicle would not be significantly more expensive than a vehicle without such measures. To achieve 80 dB(A) the manufactures would need

**ELAB** AKUSTISK LABORATORIUM

a year or two for design work and three to four years to introduce the changes in their production. However, with the political and bureaucratic inertia of legislating authorities, the process of stiffening the legislation is likely to require more time.

REFERENCES

- [1] A. Krokstad and G. Wyspianski, 1979,  
ELAB Report STF44 A79006, ELAB, 7034 Trondheim-NTH,  
Norway.  
Noise from Private Cars. Measurements on Stationary  
Vehicles.
- [2] P.E. Waters, 1974, JSV\* 35(2), 155-222,  
Commercial Road Vehicle Noise.
- [3] H.E. Head and J.D. Wake, 1980, Proceedings of  
The Institute of Acoustics spring meeting 1980.  
Noise Made by Direct Injection Diesel Engines as  
They Accelerate.
- [4] M.J. Crocker and J.W. Sullivan, 1978,  
SAE\*\* paper no: 780387. Measurement of Truck and  
Vehicle Noise.
- [5] F. Augusztinovicz and B. Buna, 1980.  
Noise Control Engineering/March-April 1980.  
An Investigation of the Close Proximity Vehicle Noise  
Survey Method.
- [6] T. Priede, 1975, JSV 43(2), 239-252.  
The Effect of Operating Parameters on Sources of  
Vehicle Noise.
- [7] M.F. Russel, 1980, Lucas Industries Noise Centre.  
Automotive Diesel Engine Noise Analysis, Diagnosis  
and Control.
- [8] "Ford Transcontinental" 1980. International Brochure.  
Published by Truck Merchandising Ford of Europe.

---

\* JSV - Journal of Sound and Vibration.  
\*\* SAE - Society of Automotive Engineers, INC.

- [9] "Nye Torpedobiler fra Scania", (Anonymous)  
Last og Buss Nr. 3, Juli-Sept. 1980. P.a.3.
  
- [10] "Seigdragningsøkonomi og Komfort Bedret i Volvo's N-Serie"  
(Anonymous), Last og Buss Nr. 2, April-Juni 1979.  
P.a.2.
  
- [11] T. Priede, 1979. SAE paper no. 790205.  
Problems and Developments in Automotive Engine Noise  
Research.
  
- [12] H.A. Kochanowski, W. Kaiser and D. Esche, 1979,  
SAE Paper no. 790451.  
Noise Emission of Air-Cooled Automotive Diesel Engines  
and Trucks.
  
- [13] "Schwere Zweiachs-Pritschenwagen von Mercedes-Benz"  
1980, Brochure. Published by Daimler-Benz AG, Stuttgart.
  
- [14] D.M. Ford, P.A. Hayes and S.K. Smith, 1979.  
SAE Paper no. 790366. Engine Noise Reduction by  
Structural Design Using Advanced Experimental and  
Finite Element Methods.
  
- [15] D.W. Rowley, 1977, SAE Paper no. 770893,  
Exhaust System Considerations for 1982 Heavy Duty Trucks.
  
- [16] T. Berge, ELAB, Arbeidsnotat 441113.01 Nr. 1 1980.  
Reiserapport fra besøk hos Volvo Lastvagnar AB  
og Saab-Scania, Scania-Divisjonen, 20-21/5.80.
  
- [17] Truck Tire Noise. SAE publication SP-373, 1972.
  
- [18] T. Berge, 1979, ELAB Report STF44 A79018,  
Støymåling på tunge kjøretøy.
  
- [19] T. Berge, 1979, ELAB Report STF44 A79058,  
Støyforskrifter for tunge kjøretøy.



- [20] R.L. Staadt, 1974, SAE publication SP-386.  
Truck Noise Control.
  
- [21] Noise and Vibration of Engines and Transmissions 1979,  
I Mech E Conference Publication 1979-10.
  
- [22] Diesel Engine Noise Conference 1979,  
SAE Proceedings P-80.
  
- [23] D.W. Rowley, 1977, SAE Paper 770893.  
Exhaust System Considerations for 1982 Heavy Duty Trucks.
  
- [24] A.R. Canthorne and J.W. Tyler, 1979.  
SAE Paper 790452. The Transport and Road Research  
Laboratory Quiet Heavy Vehicle Project.
  
- [25] J.W. Tyler, October 1979, Noise Control and Vibration  
Isolation.  
The TRRL Quiet Heavy Vehicle Project.
  
- [26] Anonymous, February/March 1979, I Mech E Automotive  
Engineer. Diesel Vehicle Noise Control.
  
- [27] O.P.A. Bühler: May 1980, VDI nachrichten nr. 22,  
p 13-14. "Lärmarmes LKW" ist serienreif.

APPENDICES

- I Experimental Set-up and List of Instruments.
- II Number of Trucks Sold in Norway During 1977-78-79.

APPENDIX I

Equipment for Near Field and Reference Measurements.  
(See page AI-3 for explanation of letter codes)

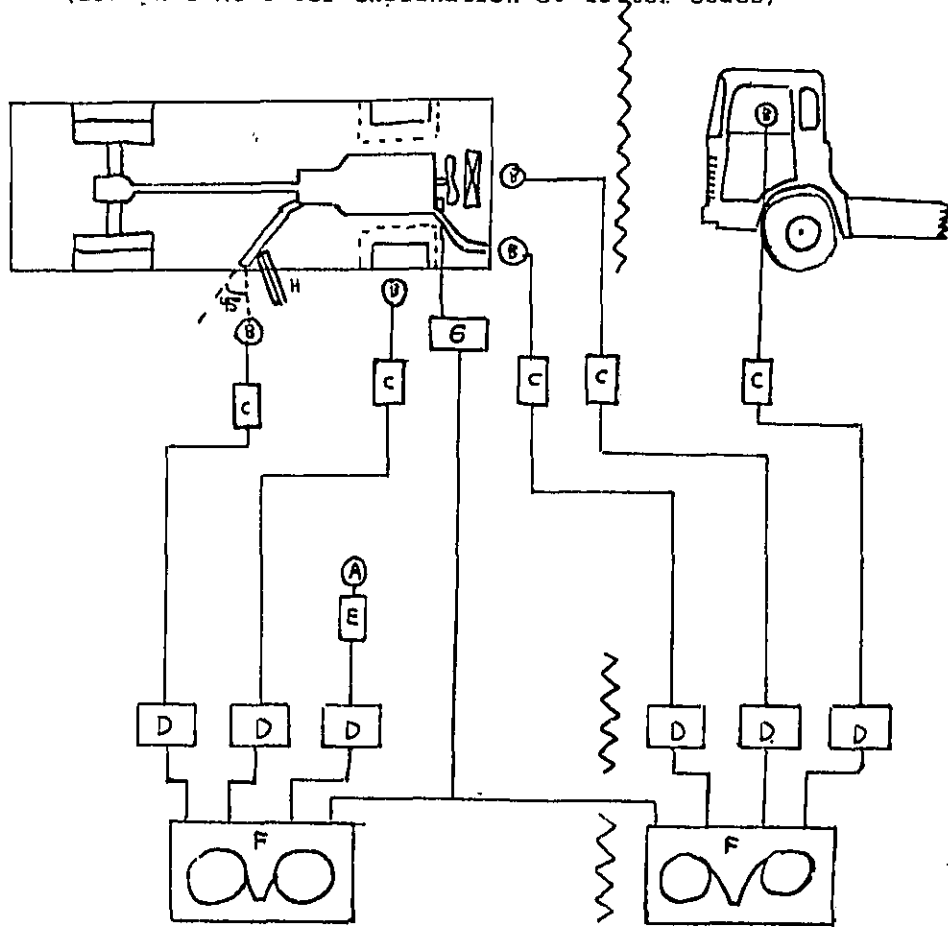

Equipment for Analysis.

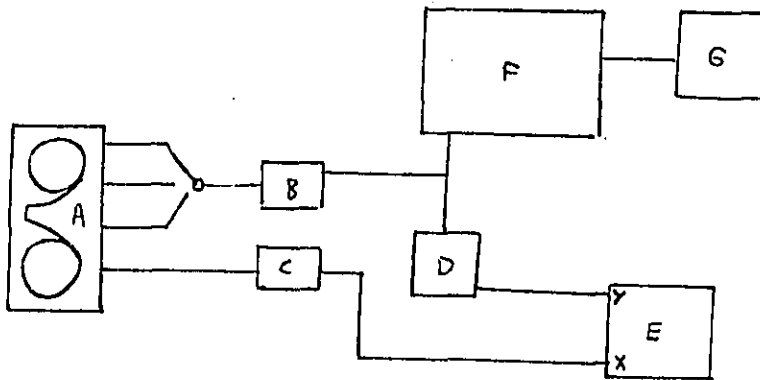

Equipment for Rolling Noise Measurements.

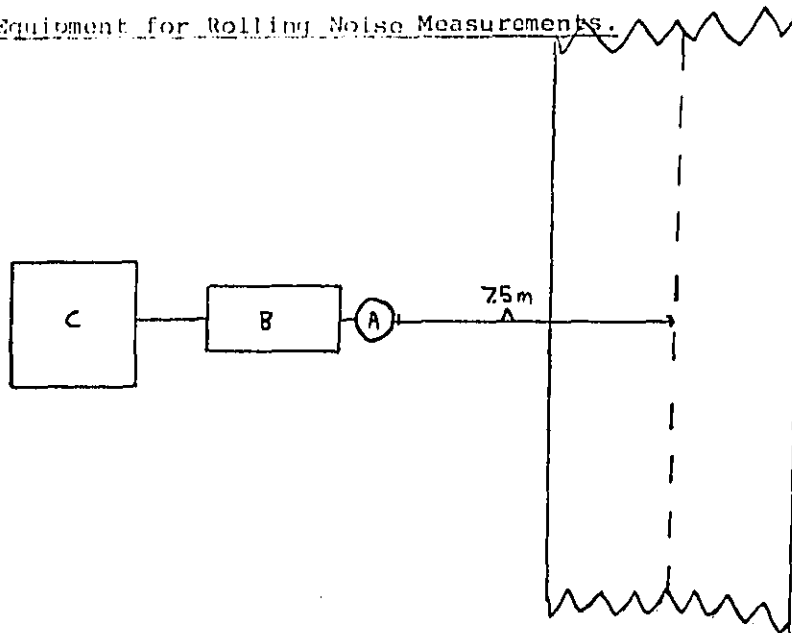

Equipment for Vibration Measurements.

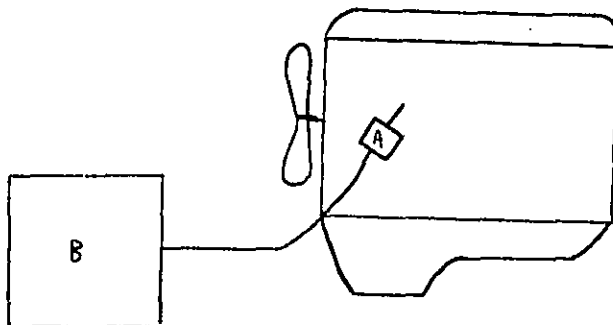

LIST OF INSTRUMENTS USEDReference and Near Field Measurements:Letter  
code

1	Brüel & Kjør (B&K)	4145	1" Condenser Microphone	A
3	B&K	4144	1" Condenser Microphones	B
3	B&K	2801	Microphone Power Supplies	C
3	B&K	2619	Microphone Pre-Amplifiers	
3	B&K	2608	Measuring Amplifiers	D
1	B&K	2203	Sound Level Meter	E
1	Racal	405	FM Tape Recorder	F
3	B&K	4230	Calibrators	
1	Rohde & Schwarz Elmot		RPM Meter with Optical Probe	G
1			Barrier	H

Analysis

1	Racal	405	FM Tape Recorder	A
1	B&K	2608	Measuring Amplifier	B
1	Ithaco	4251	HP Filter	C
1	Hewlett Packard (H.P)	7562A	Log-Lin Transformer	D
1	H.P.	7015A	X-Y Recorder	E
1	H.P.	5420A	Signal Analyser	F
1	H.P.	7225A	Digital Plotter	G

Rolling Noise

1	B&K	4145	1" Condenser Microphone	A
1	B&K	2203	Sound Level Meter	B
1	B&K	4230	Calibrator	
1	B&K	2306	Graphic Level Recorder	C

Engine Vibration

1	B&K	4370	Accelerometer	A
1	B&K	2511	Vibration Meter	B

APPENDIX IINumber of Trucks Sold in Norway during 1977-78-79

From: Bil og Vei. Statistikk 1980.

Opplysningsrådet for biltrafikken. Den norske veiforening.

No.	Make	No. of Trucks Sold during the last 3 Years	Percentage of the market %	Ranked after 1979 sales only
1	MERCEDES BENZ	3799	22,4	2
2	VOLVO	3147	18,5	1
3	SCANIA	1833	10,8	4
4	FIAT	1756	10,4	3
5	FORD	1675	9,9	5
6	DODGE*	611	3,6	6
7	MAGIRUS DEUTZ	590	3,5	9
8	BEDFORD	553	3,3	8
9	TOYOTA	378	2,2	7
10	DAF	217	1,3	11
11	CHEVROLET	183	1,08	10
12	NISSAN	72	0,4	12
13	HINO	71	0,4	13
-	OTHER MAKES	431	2,5	
	TOTALLY	16947		

\* Only models with petrol engines imported 1980.